

INSTRUCTIONS RW 00SR

零号模式

Installation and debugging
strategy

from novice to semi expert
从小白到“半高手”的
安装调车攻略

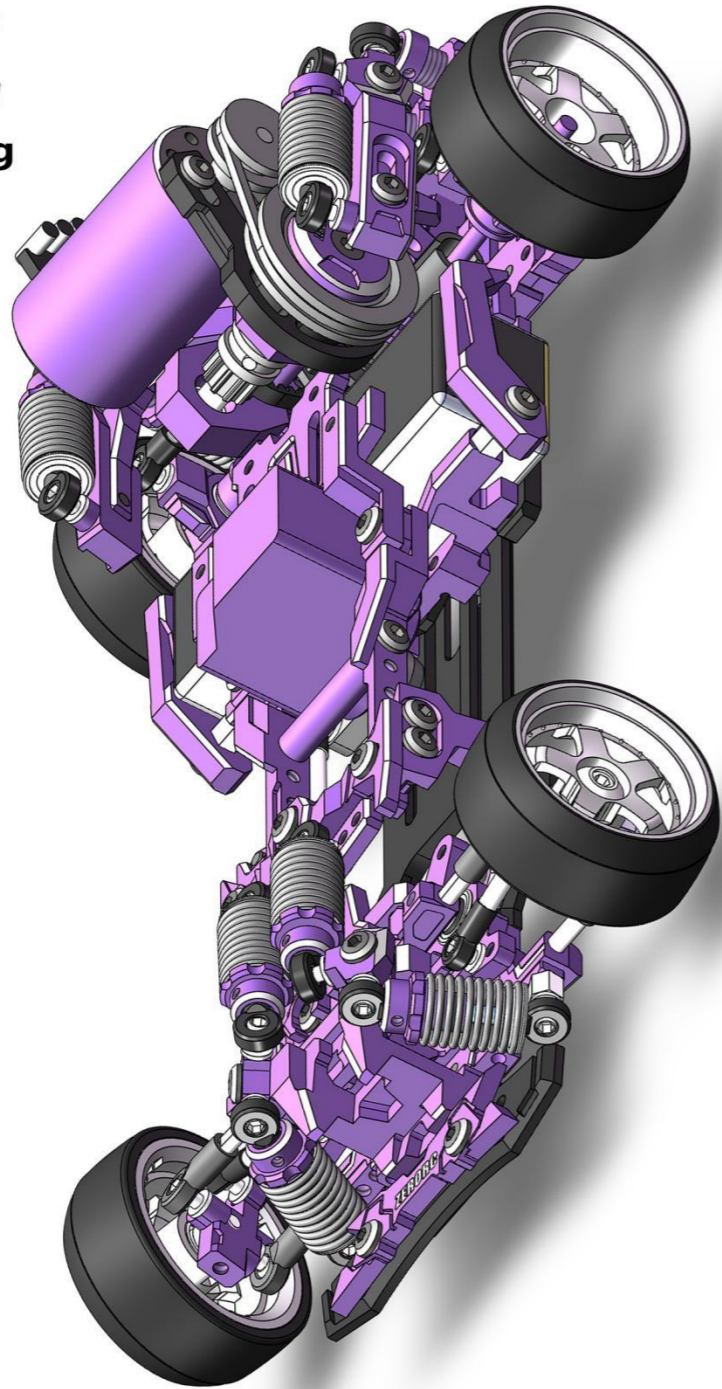

真正的高手
车都是追求个性化
Real master
Cars are all personalized

通用安装细节技巧
车架参数调节带来的应用效果
General installation details and skills
Application effect brought by vehicle parameter adjustment

从这里开始走出你的个性化之路
From here, walk out of your personalized road





PARTICIPATE IN EVENTS

参与赛事追求多种个性

赛事现场



赛前练习



赛员合照



追走比赛

参赛实例



GT86+V3



SUPRA+V3



GTR34



GT86+V1

INSTRUCTIONS
RW OOS

零号模式

— 0 1

About
Playing

追求的玩法

ABOUT RW 00

产品的追求

01
快乐
Joy

就是为了快乐

玩了多年的开放式车架，让我感受到了调车后带来各种手感变化的乐趣。我希望可以通过RW00和调车攻略，让大家也感受到这份快乐

感受追走的快乐

漂移的追走玩法，其实就是一个格斗游戏。玩家之间可以通过调车达到一个最合适自己手感车架。真正的高手车架都是极具个性化的。

02
竞技
Sports

03
美观
Nice

除了帅一无事处

车架的外观设计花费了大量的时间和精力，在我看来，除了帅一无事处。

04
互动
Interaction

分享你的快乐

欢迎加入到我们社群的大家庭里，群内有多位资深玩家分享玩车的经验。更希望大家可以把自己玩车的快乐分享给身边的好友。



01 COMMON TOOLS 常用工具

常用的工具必不可少，
例如：螺丝刀、镊子、手钻、
钻头，在安装车架，改装车壳
上面都要用到。



03 INSTALL 安装车架

除了常规的安装说明，还详
细介绍一些通用的精装、改
装技巧。



05 DEVICE SETTINGS 设备设定

电子设备的参数分享，及实
际应用效果。电子参数在整
个车架里面的影响效果占比
相当之高。



07 SKILL 操控技巧

讲述对于每个湾道的控
线技巧，追走时候的后
车位置选择。

车架电子设备的选用，电
机、电调、舵机、陀螺仪
会从入门级到进阶级做一
个相应的介绍。

电子设备 02 ELECTRONIC



车架上的各个物理参数
介绍，参数间的各种关
联，调教后的实际应用
效果。

车架调教 04 TUNING CAR



所有的参数其实都是根据
线路、地面而设定。讲述
入弯，出弯的线路选择，
各选择之间的优劣。

漂移路线 06 DRIFT ROUTE



一般漂移追走比赛的赛制
讲解。车架设定差异，对
局之间心理战的技巧

漂移比赛 08 DRIFT RACE



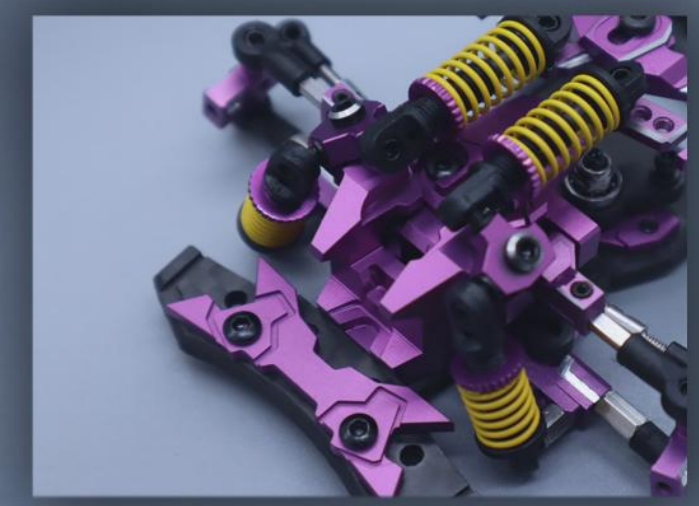
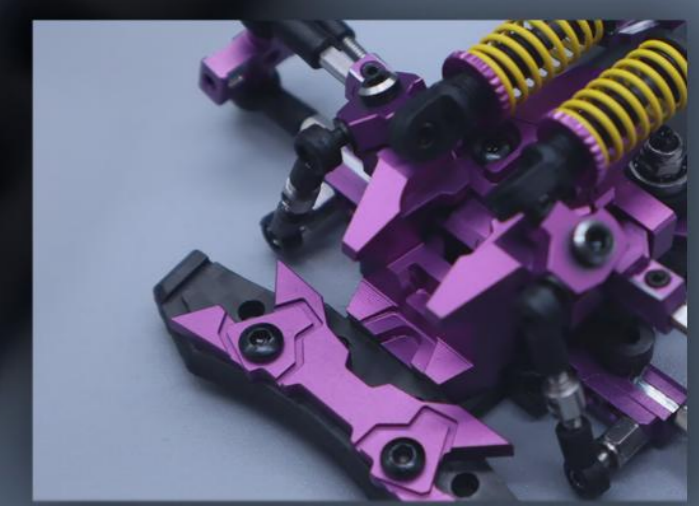

ZERORC
WWW.ZERO-RC.COM

RWOOS

Treatment of ball connector

球头的处理

During installation, if the ball connector is stuck or not smooth, You can use pliers to clamp it gently at multiple angles. It feels that there is a complete fit between metal and plastic.

在安装的过程中，如果遇到球头出现顿卡或不顺畅，可以用钳，多角度轻轻夹一下。力度为感觉金属与塑料之间完全贴合。

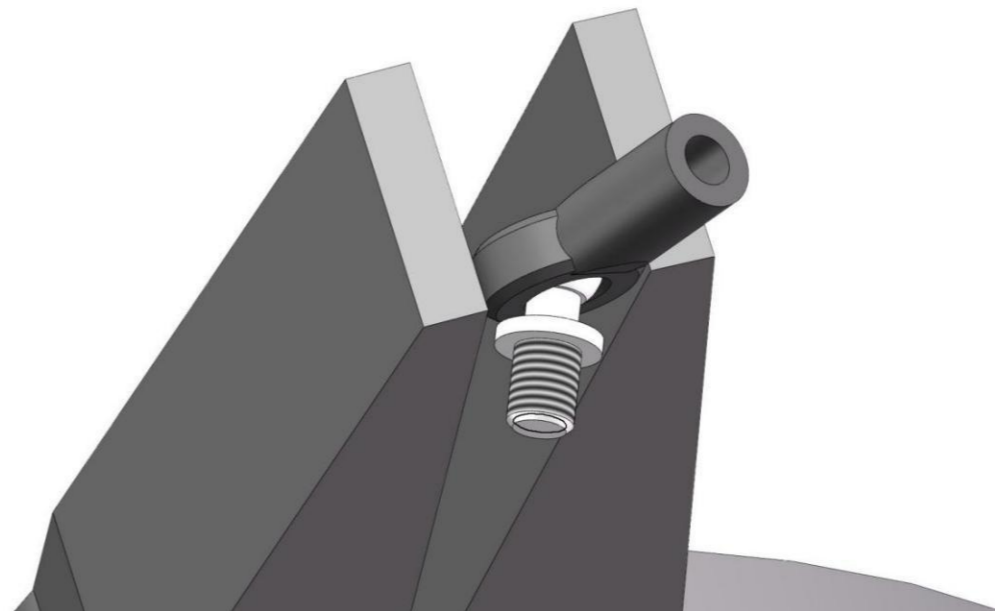
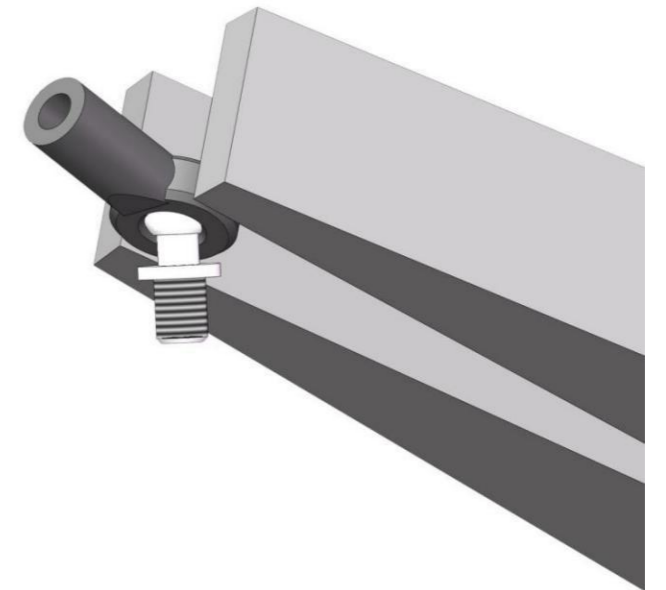
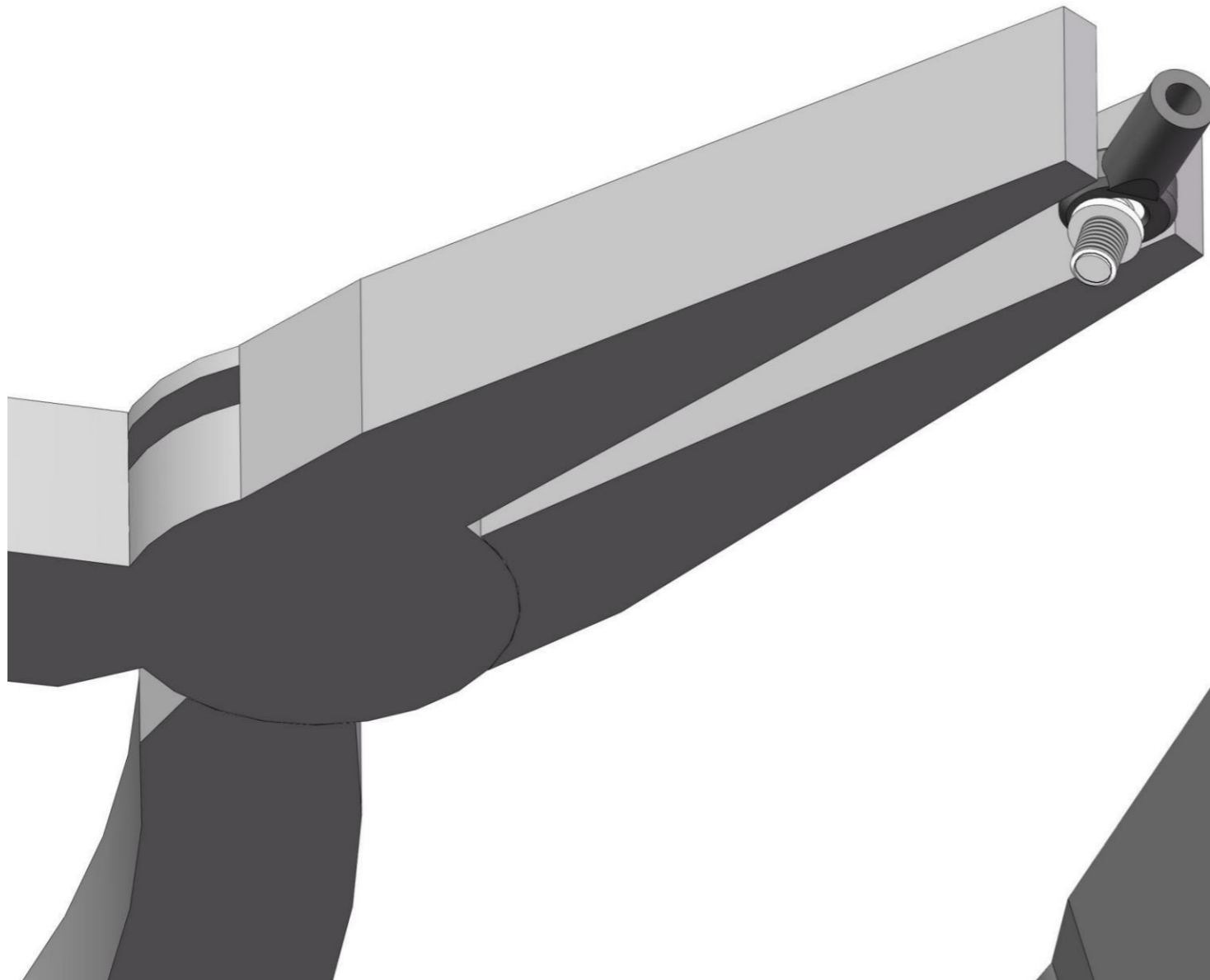
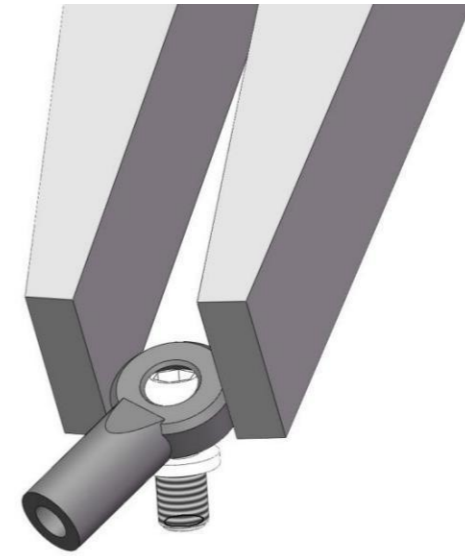

Performance upgrade

性能大幅提升

New metal steering system
Rear suspended server
High traction bottom plate
Rear two-stage suspension

Significantly improve flight distance and stability

全新金属转向系统
后置悬空伺服器
高牵引力底板
后双段式避震

大幅提升飞行距离
以及稳定性

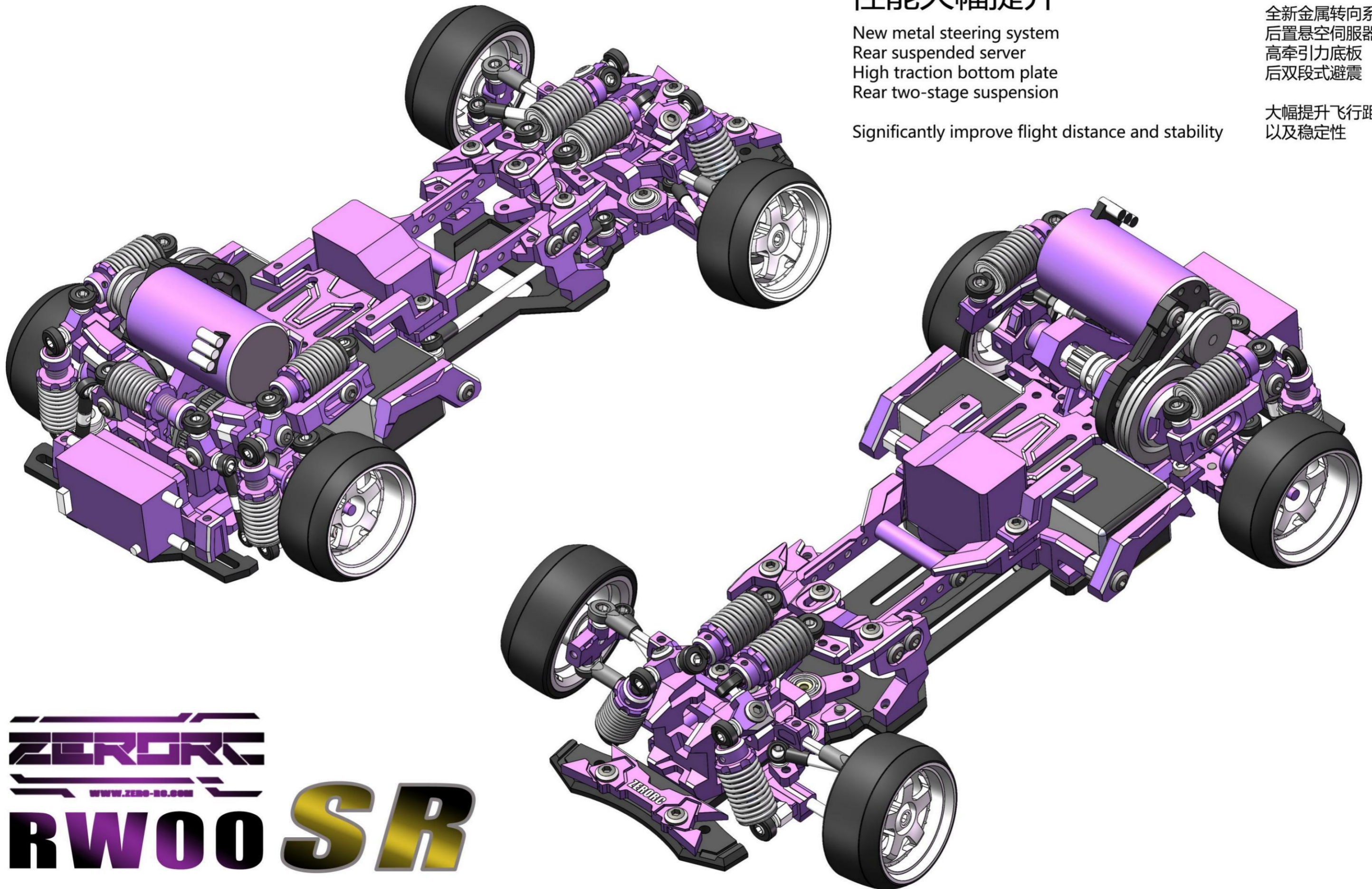

ZERORK
WWW.ZERORK.COM

RW00 SR

Front suspension instructions

前避震功能说明

原厂状态
Default state

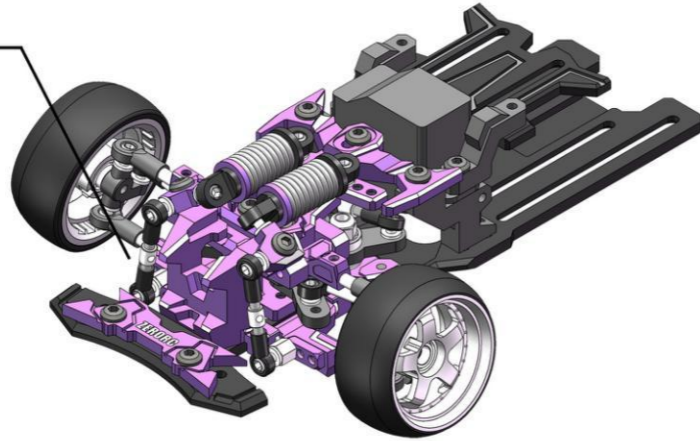

更改位置，悬挂更容易压缩与恢复。
Changing the position makes suspension easier to compress and recover

Increase stability
增加稳定性

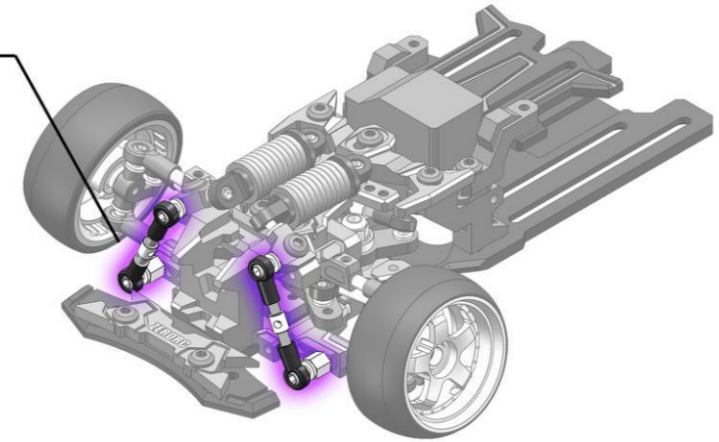

垫片改变位置，使力臂长度改变。
使悬挂压缩容易，恢复变难。

Change the position of the gasket to change the length of the force arm. Make suspension compression easier and recovery more difficult.

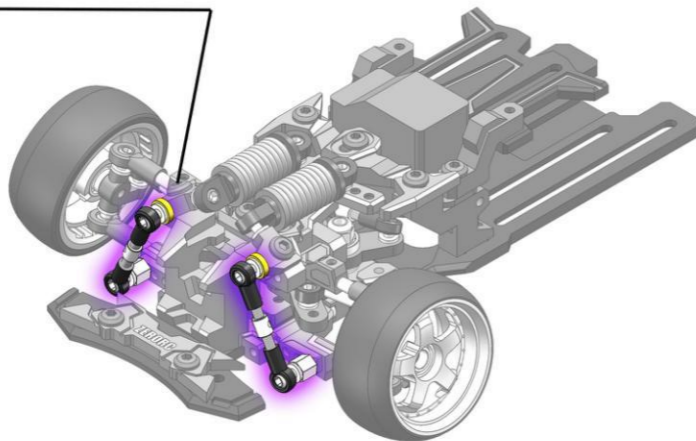

增加垫片改变力臂，
使悬挂压缩变难，恢复变容易。

Adding shims to change the force arm makes suspension compression more difficult and recovery easier.

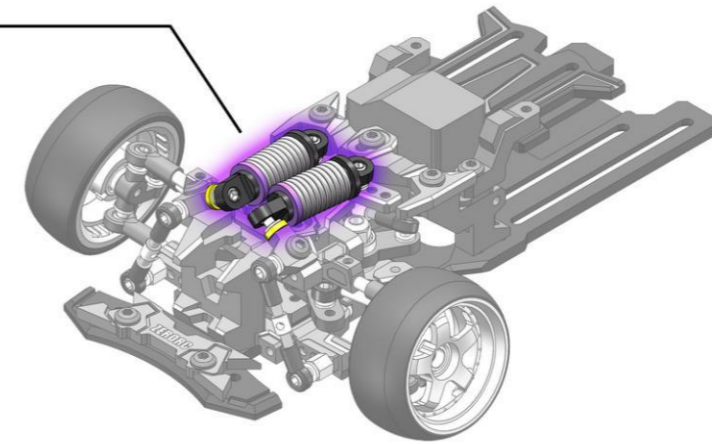

Apex increases stability
增加弯心稳定性

Increase corner exit performance
增加出弯性能



RWOOS

Front suspension instructions

前避震功能说明

增加一组避震，会使转向性能更加线性
Adding a set of shock absorbers will make the steering performance more linear

Priority work during the Corner phase

入弯阶段先工作

Work after reaching the apex
到弯心阶段后再工作

Changing the position makes suspension easier to compress

更改位置，悬挂更容易压缩

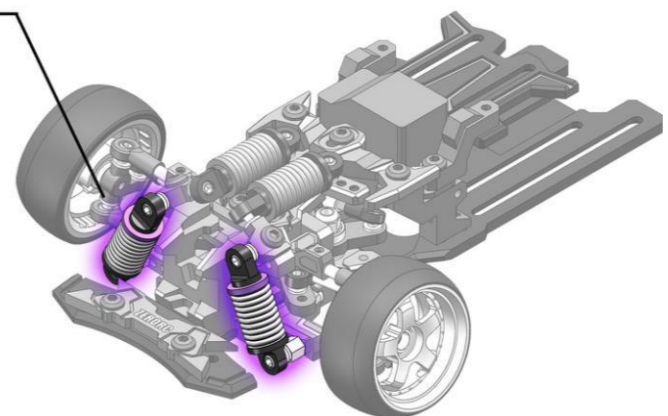
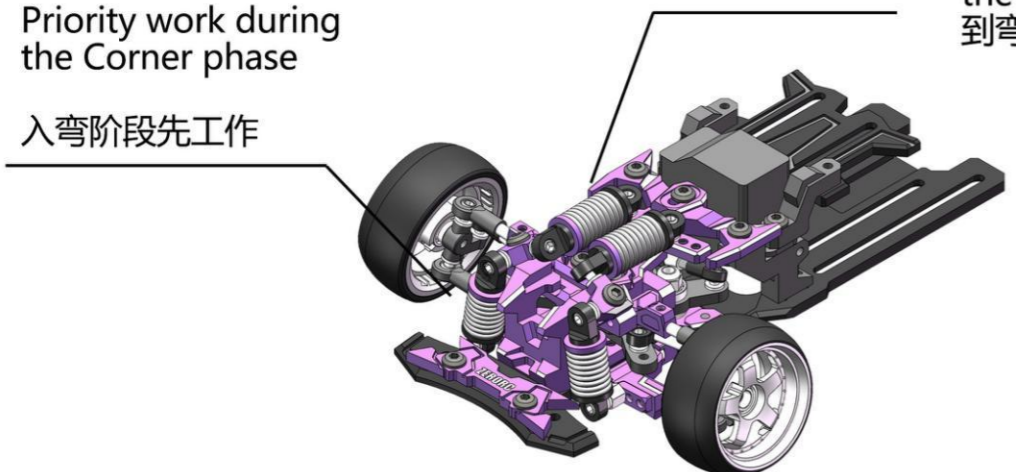

Into the Corner to increase stability
入弯阶段增加稳定性

Change the position of the gasket to change the length of the force arm. Make suspension compression easier and recovery more difficult.

垫片改变位置，使力臂长度改变。使悬挂压缩容易，恢复变难。

Apex increases stability
增加弯心稳定性

Adding shims to change the force arm makes suspension compression more difficult and recovery easier.

增加垫片改变力臂，使悬挂压缩变难，恢复变容易。

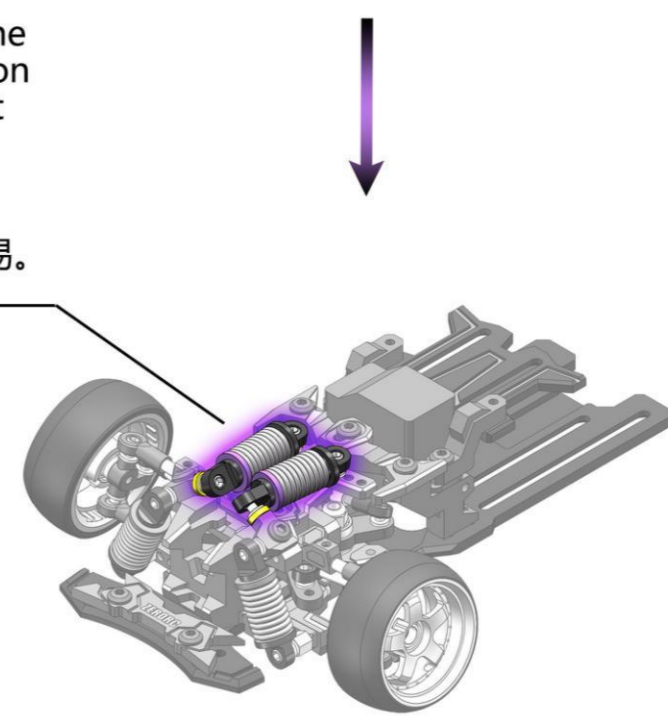
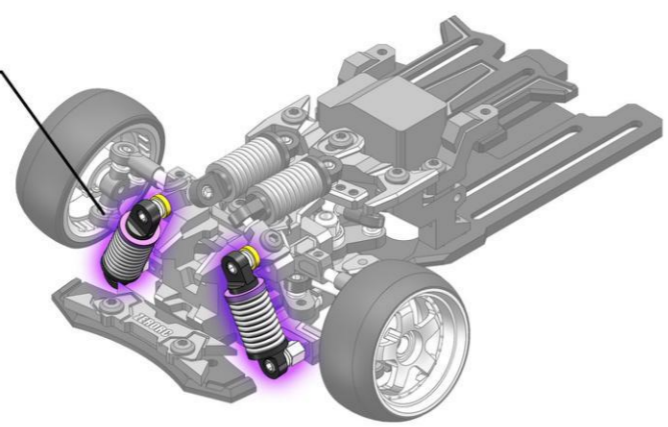

Increase corner exit performance
增加出弯性能

ZERORO
WWW.ZERO-RO.COM

RW00 SR

Rear suspended server 后置悬空舵机

Increase pendulum force to enhance overall flight distance.
增加钟摆力，提升整体飞行距离。

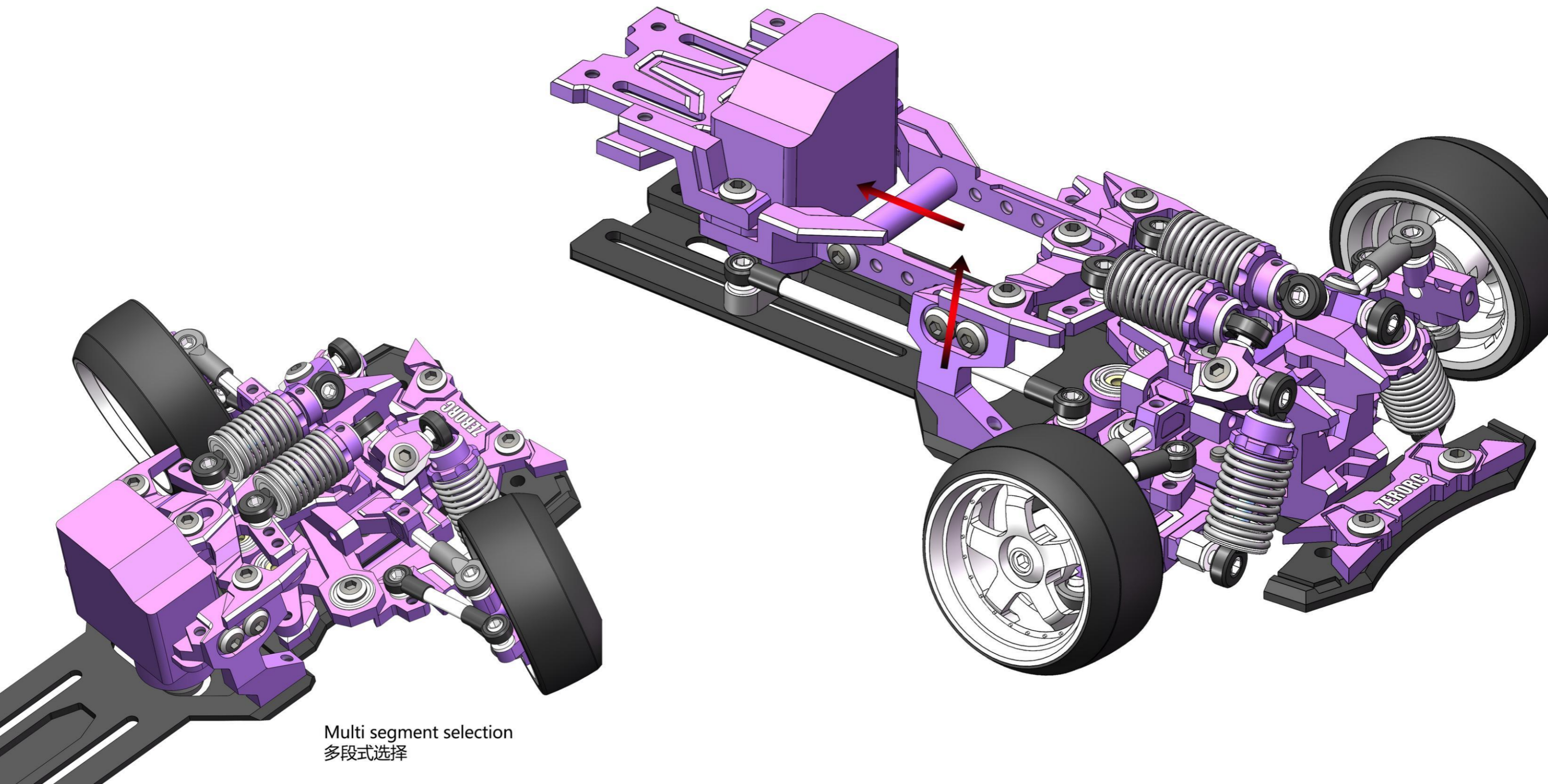



RW00 SR

New metal steering system 全新金属转向系统

Add KPI parameters
增加KPI参数

Add Trail parameter
增加拖拽距参数

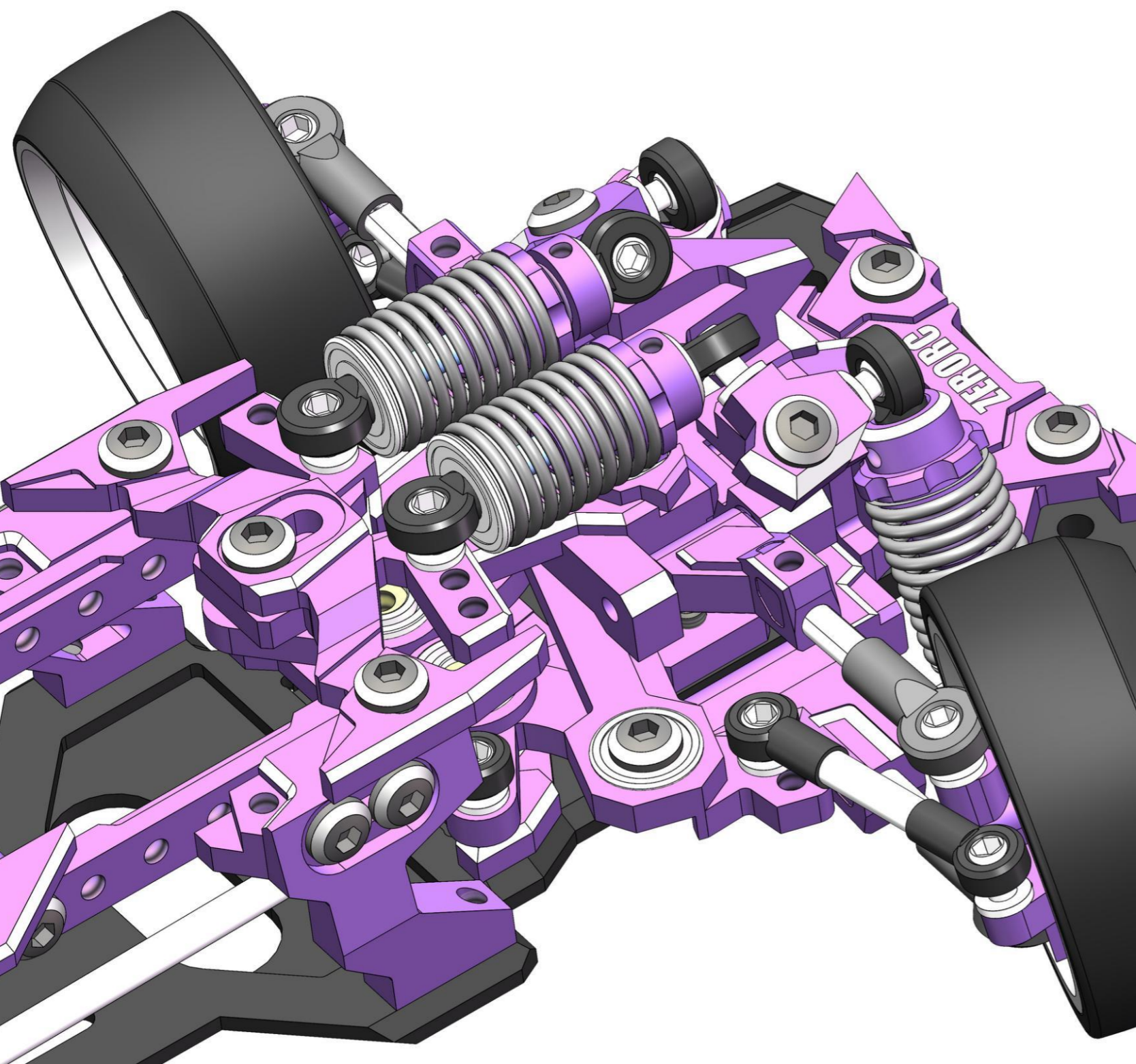

MR

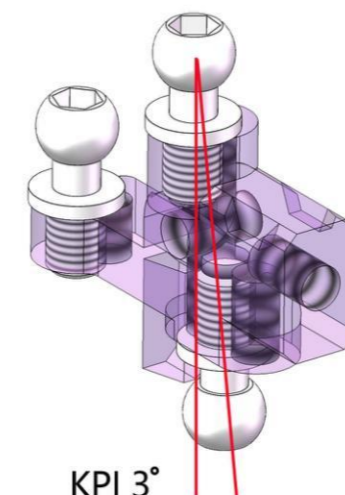

KPI 3°

AWD

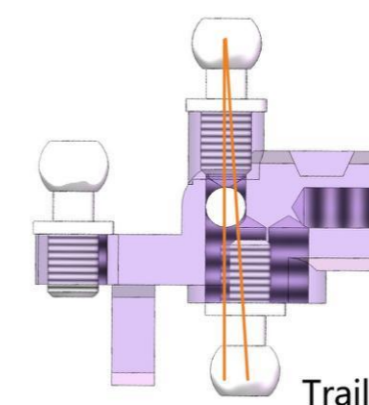
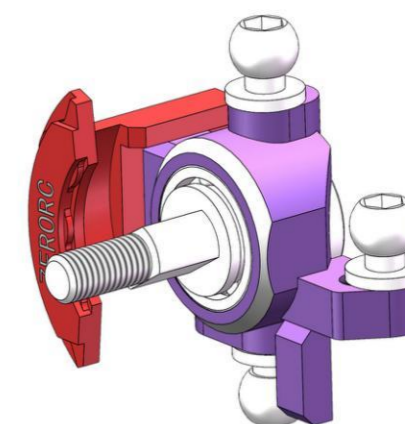

Trail 3°

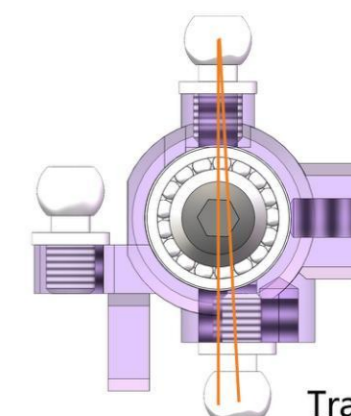

Trail 3°

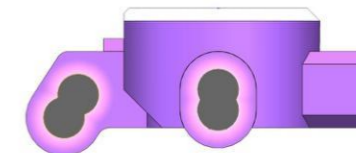
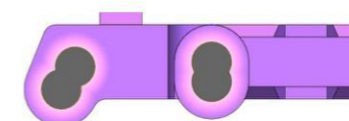
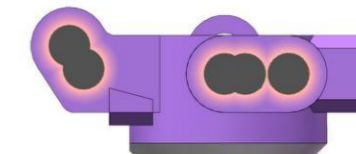
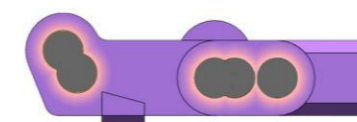

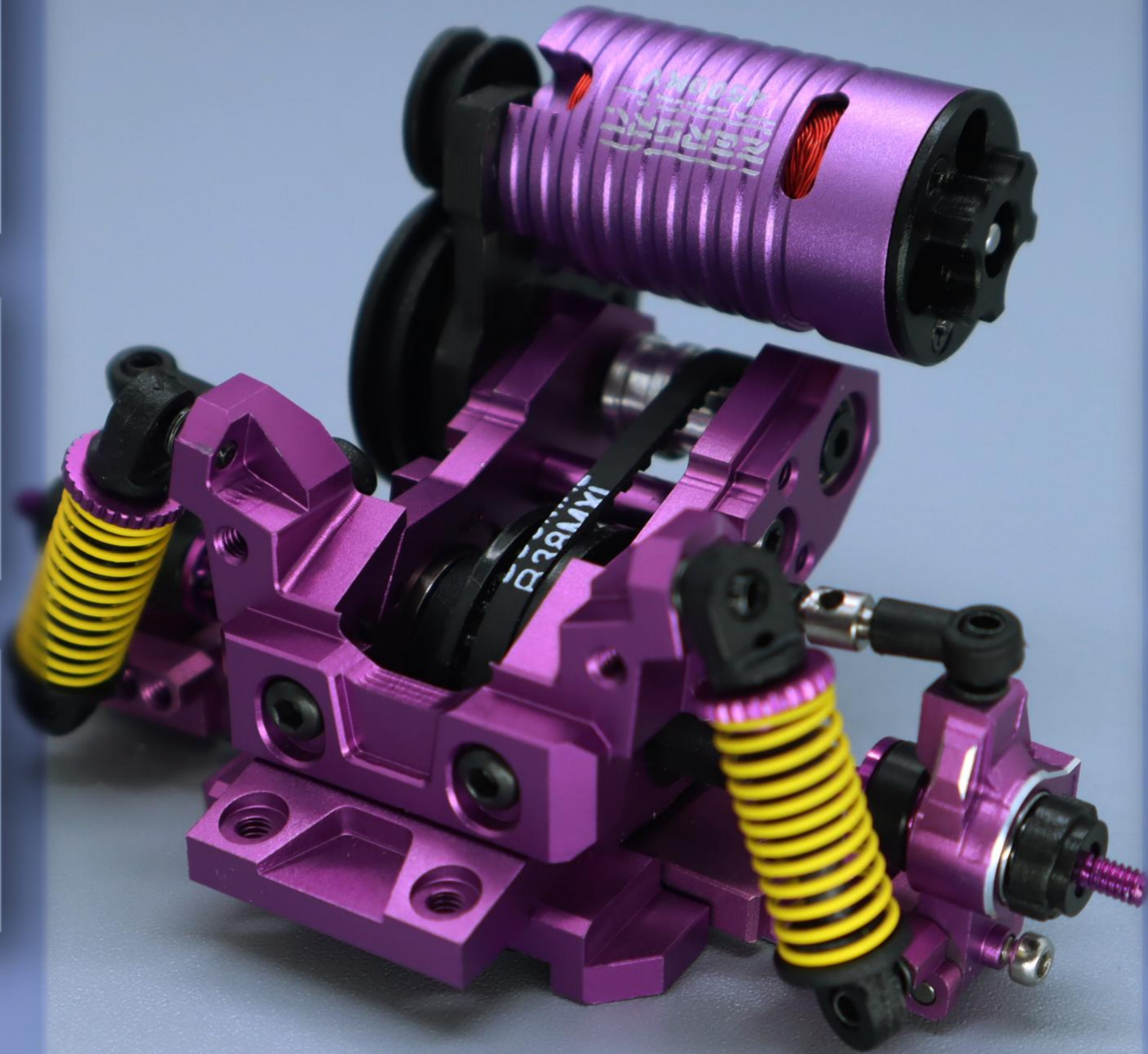

ZERORE
WWW.ZERORE-RC.COM

RWOOS

Rear toe adjustment

后束角调整

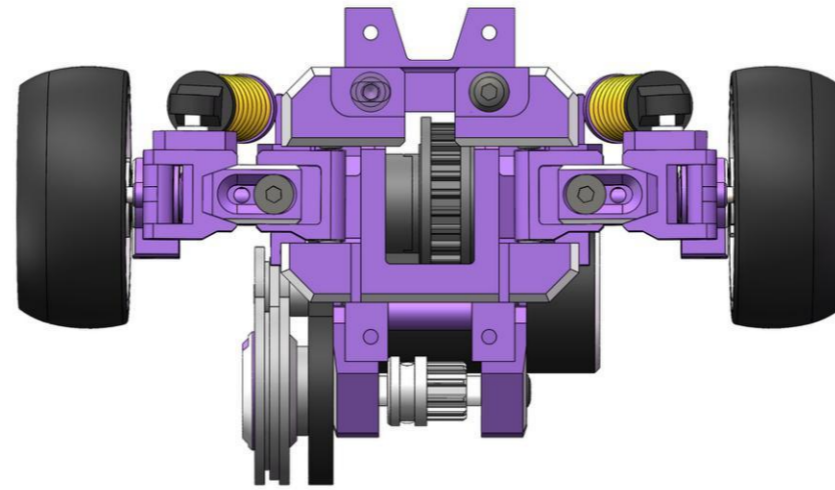

通过左右调整此零件，可以调节束角的大小，适用于MR模式与RR模式。

By adjusting this part left and right, the size of the toe angle can be adjusted, suitable for MR mode and RR mode.

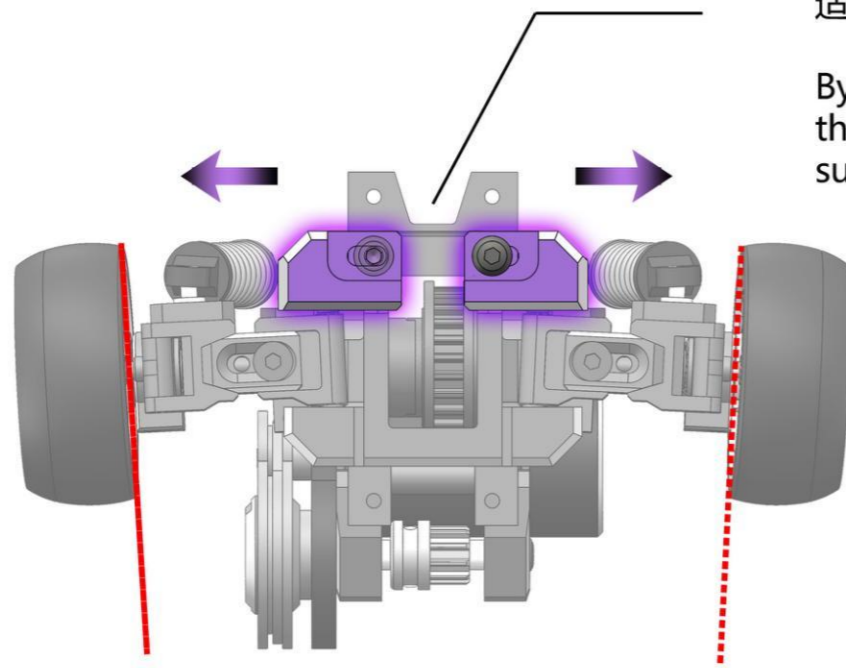

MR mode
MR模式

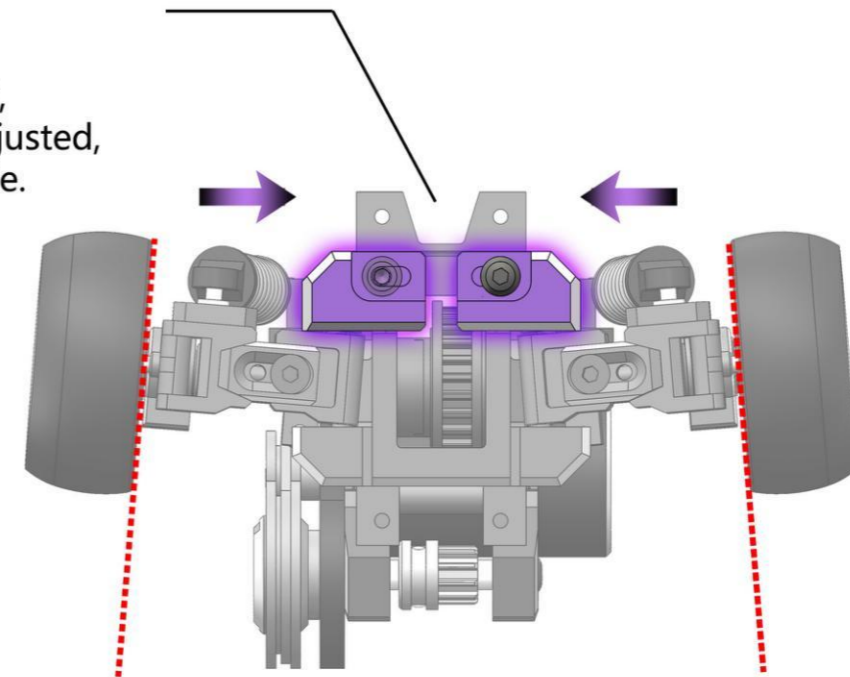

RR mode
RR模式



RWOOS

Rear anti-squat adjustment

后防蹲角调整

By the number of shim,
adjusting the anti-squat.
通过垫片的数量, 调节防蹲角。

2x4x0.5 Shim

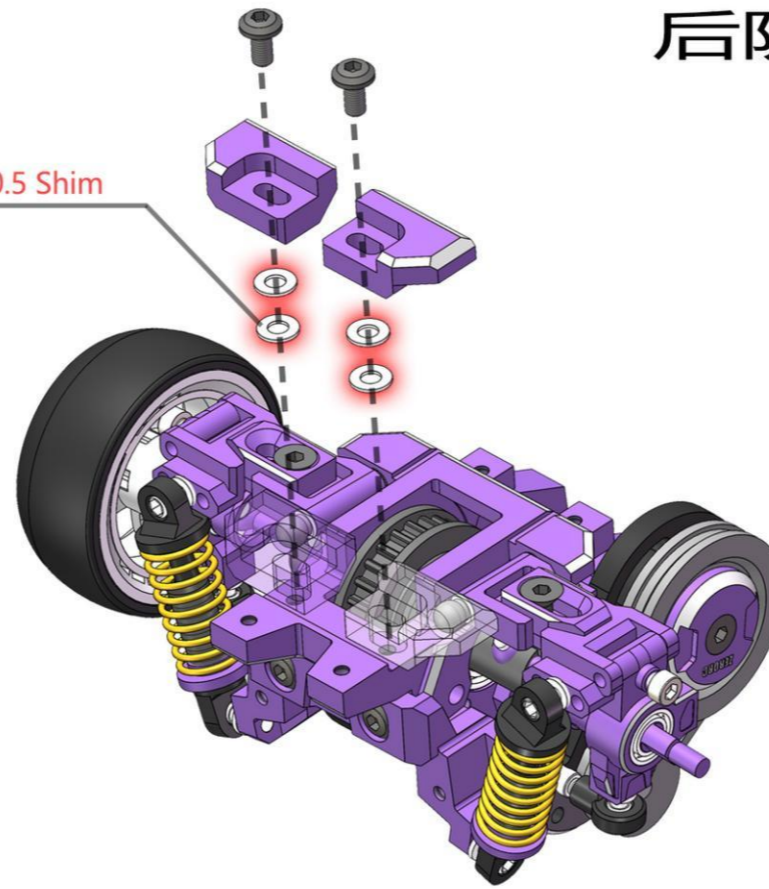

Shim 0

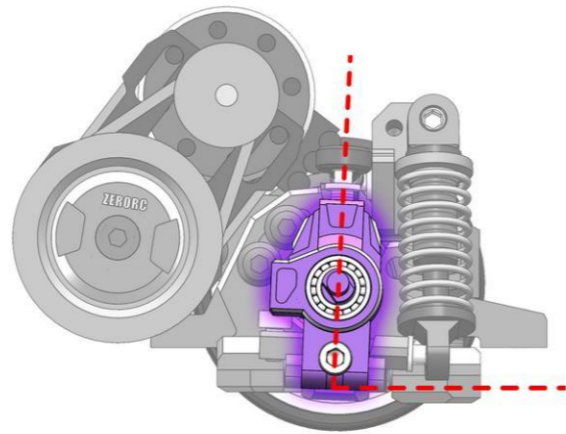

Starting action: fast
起漂动作: 快

Shim 1

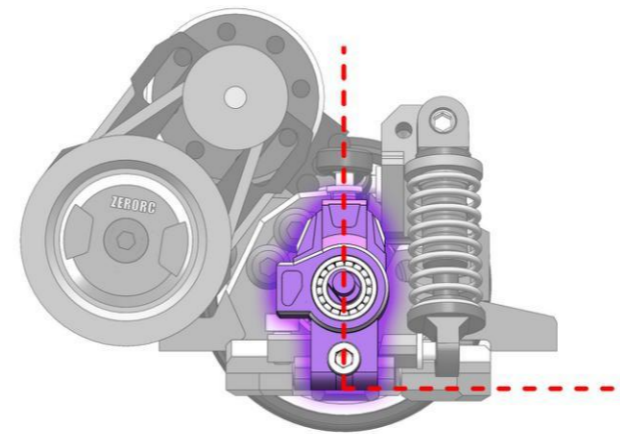

Starting action: Normal
起漂动作: 一般

Shim 2

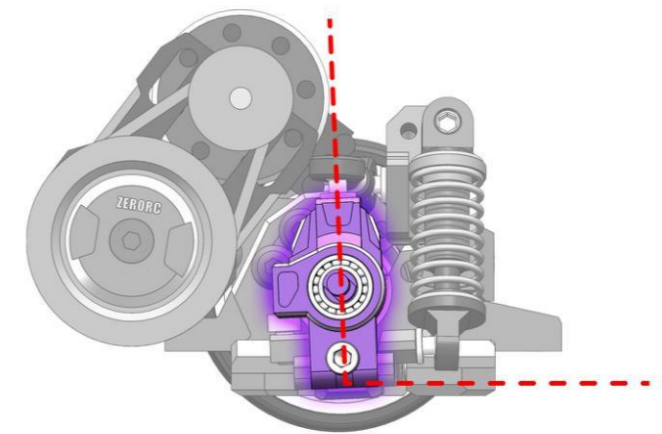

Starting action: Stable
起漂动作: 稳定



RWOOS



Front of the car
车头方向

1-02

RW00S
install

RW00S车架组装

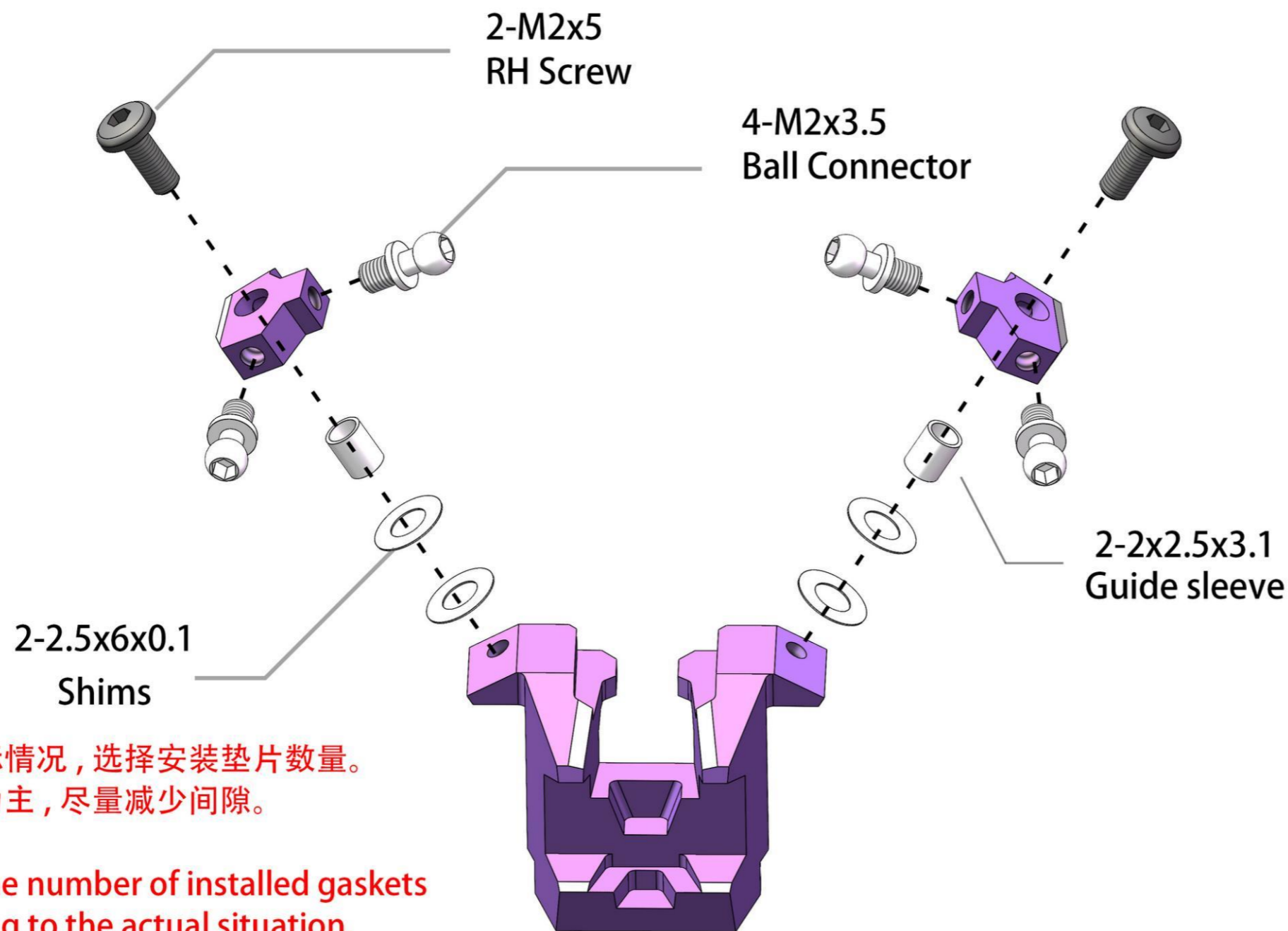

根据实际情况，选择安装垫片数量。
以顺畅为主，尽量减少间隙。

Select the number of installed gaskets
according to the actual situation.
Mainly smooth and minimize the gap.

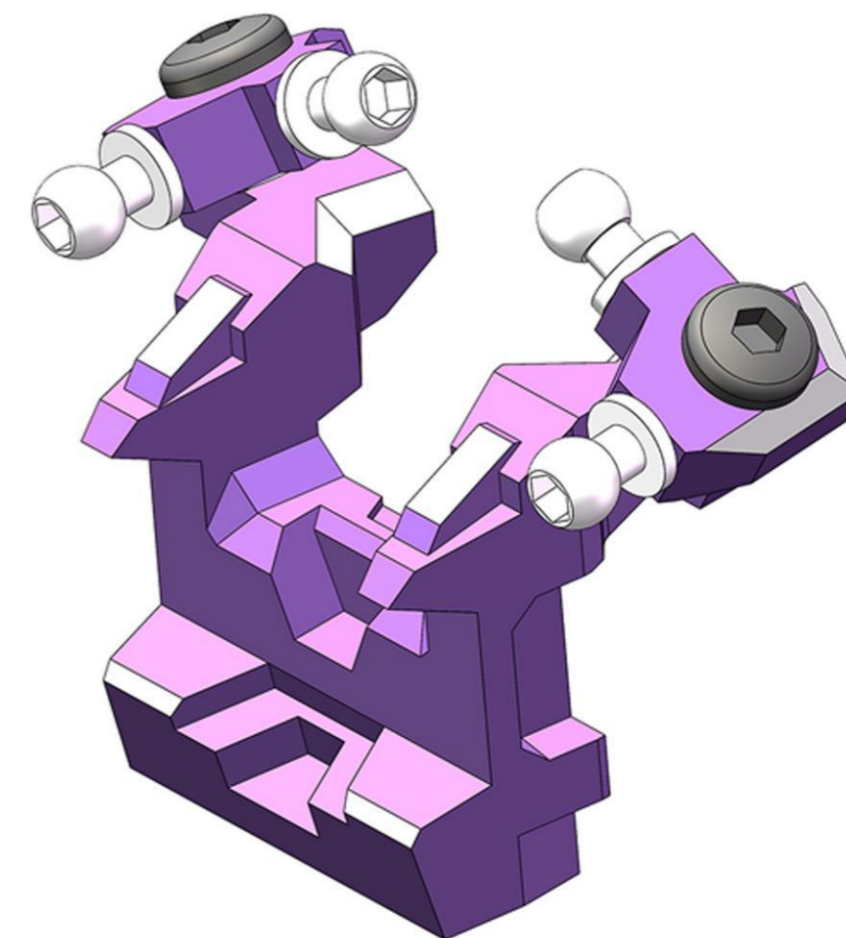

Options Shock Adapter

OP轴承避震转接器

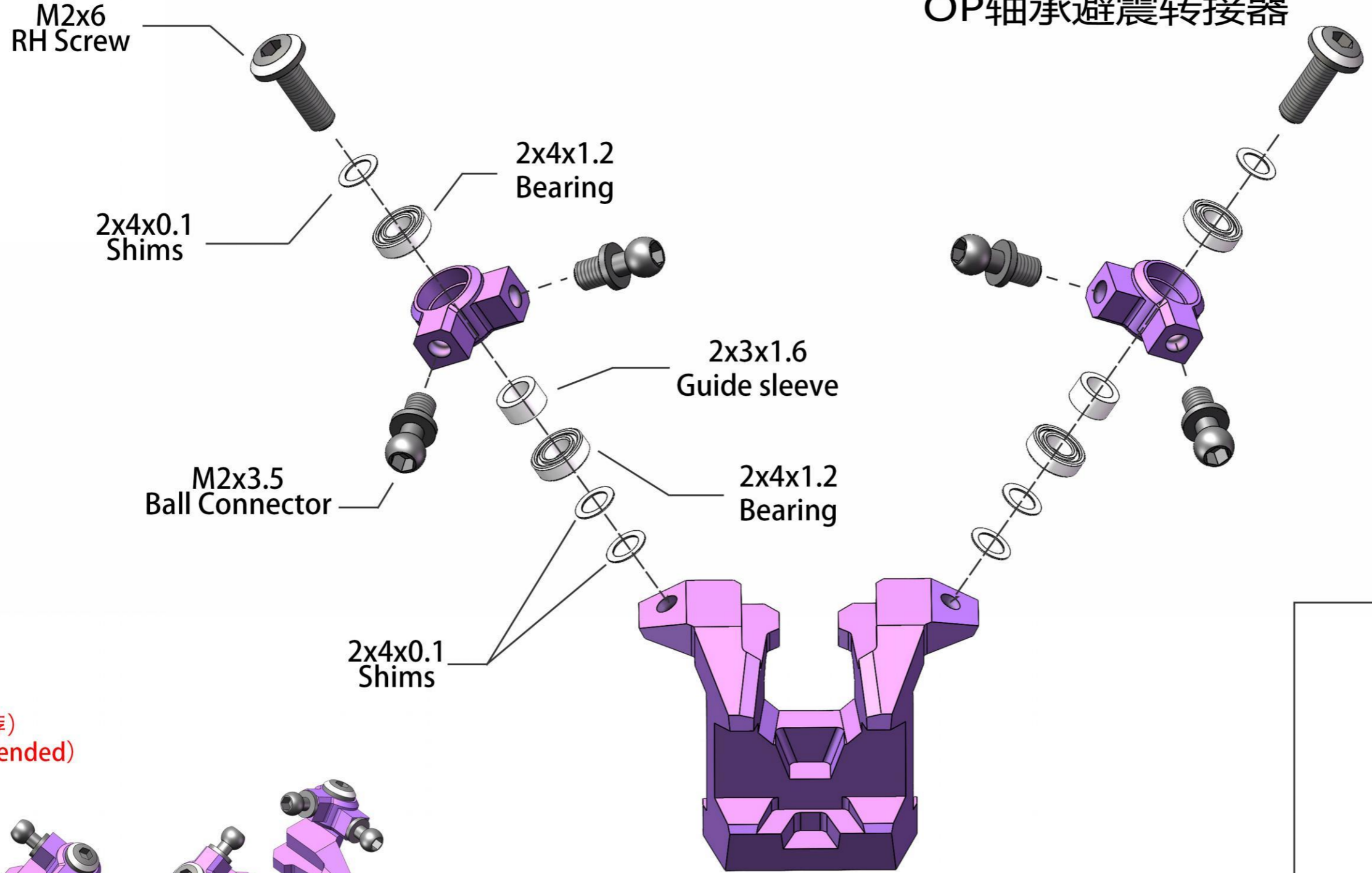

(推荐)
(Recommended)

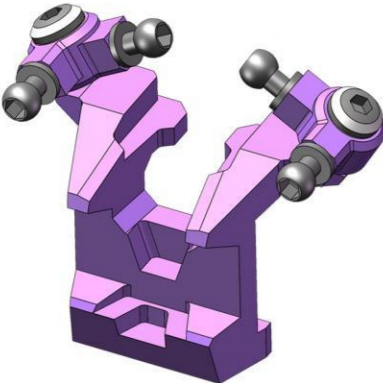

适合长湾跑道
Long Sweeper

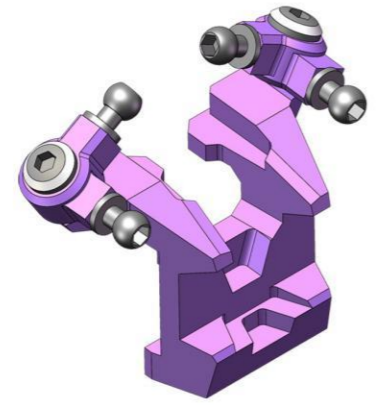

适合急湾跑道
Tight Corner

- 可根据不同的赛道条件，选择向前或向后安装。
- 可逆安装，适用于不同的轨道布局。
- Can be installed forward or backward to suit different track conditions.
- Reversible installation for different track layouts.

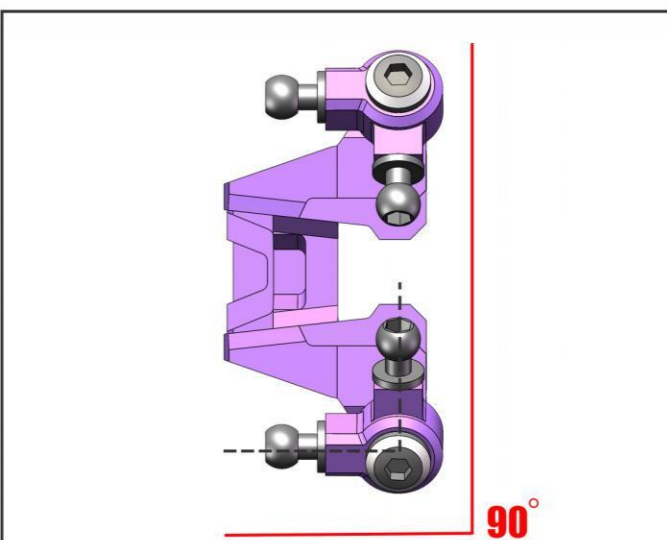

在设定底盘时，请调整到接近此角度。

When setting the chassis, please adjust it to a position close to this angle.

2-10mm
Ball Head

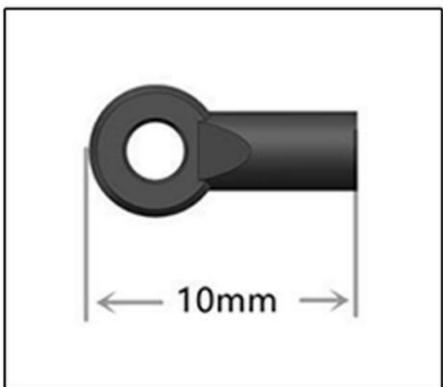

2-M2x2.5
Set Screw



2-M2x4
RH Scerw

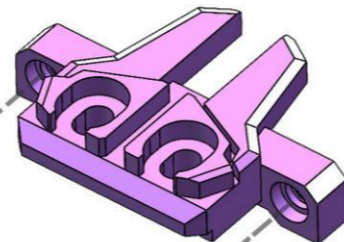

2-1.5x14
Pin

使用短的
Using Short

根据不同车身宽度，选择长或短。

Choose long or short according
to different body widths.

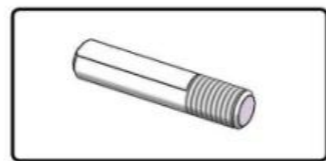

2x4x0.1
Shims

如果出现插销 (Pin) 掉出来的现象，
可在此处增加垫片。

If the phenomenon of the
pin falling out occurs,
a spacer can be added here.

以顺畅为主，调节最小间隙。
Mainly smooth, and adjust
the minimum clearance.

4mm

调整距离至 4mm
Adjust the distance to 4mm

4mm

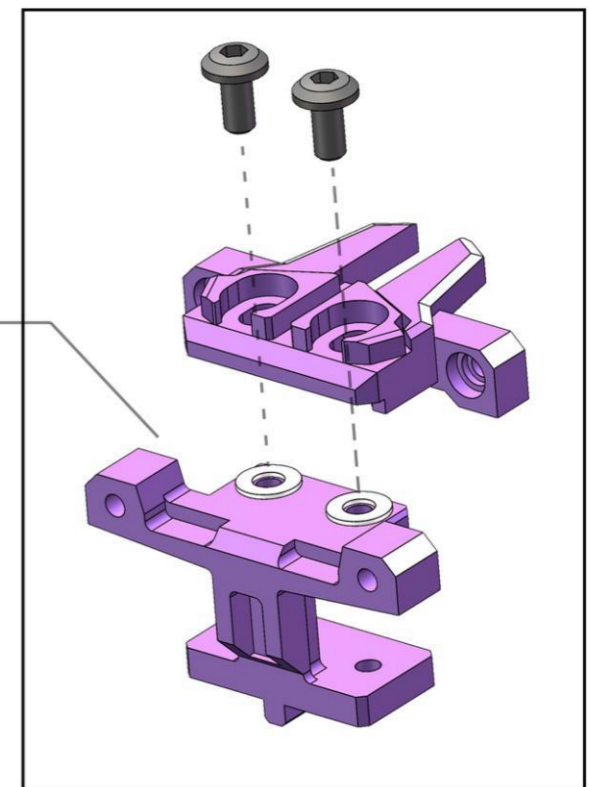

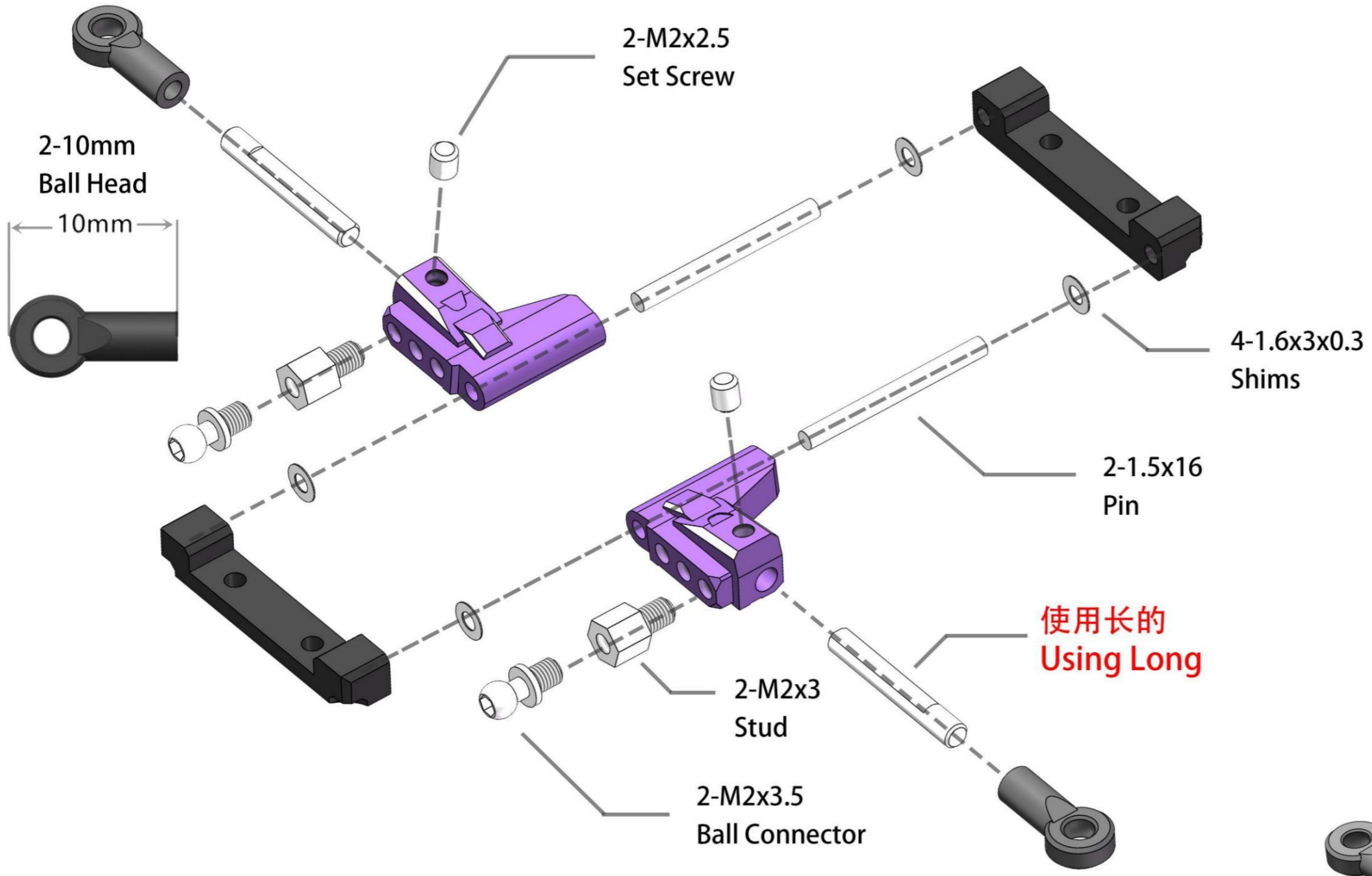

根据实际情况，可以更换或增加 1.6x3x0.1 垫片以顺畅为主，尽量减少间隙。
According to the actual situation, 1.6x3x0.1 gasket can be replaced or added, Mainly smooth and minimize the gap

根据不同车身宽度，选择长或短。
Choose long or short according to different body widths.

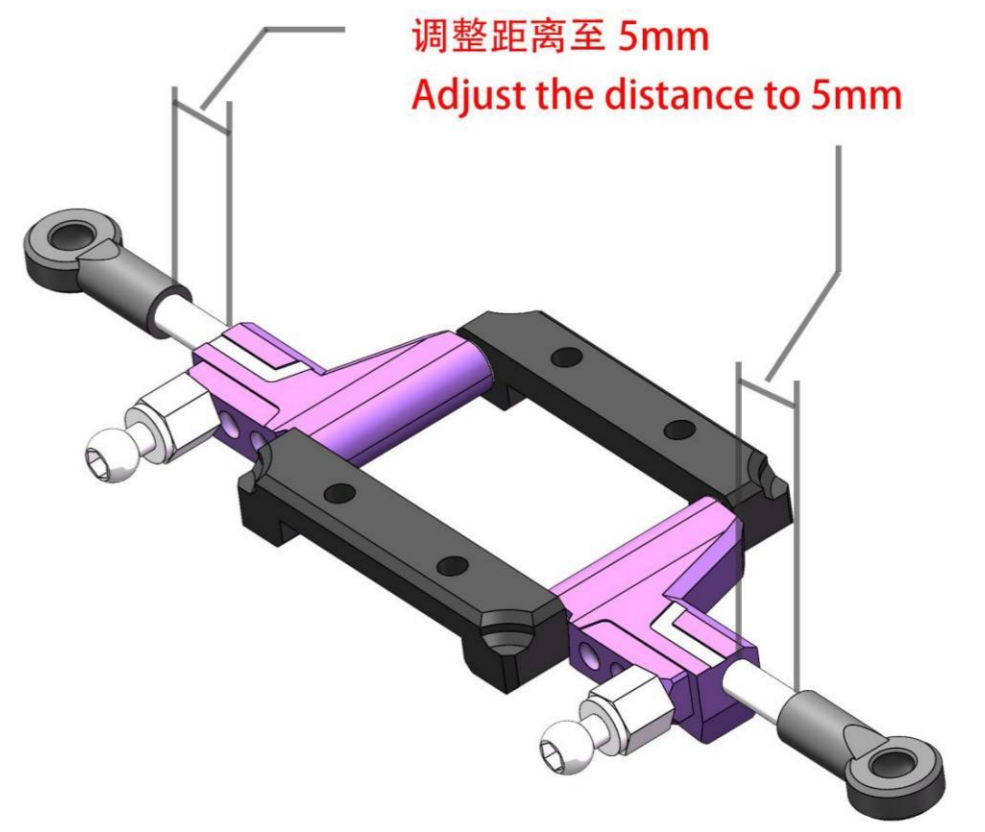
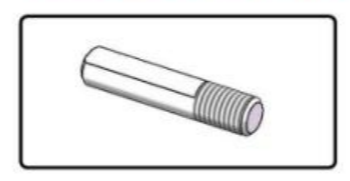

根据实际情况，可以更换或增加 1x2x0.1 垫片，以顺畅为主，尽量减少间隙。

According to the actual situation, 1x2x0.1 gasket can be replaced or added, Mainly smooth and minimize the gap.

Optional parts 选装升级配件

Bearing swing arm seat 轴承摆臂座安装方式

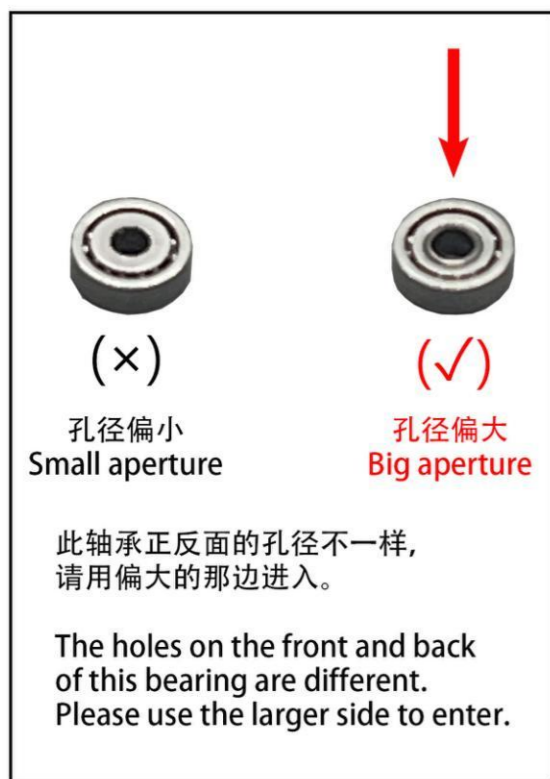
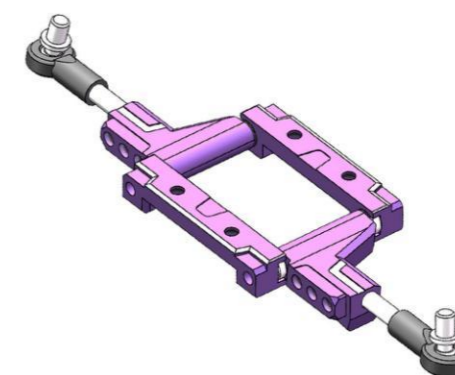
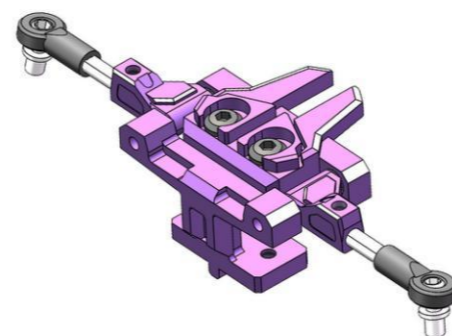
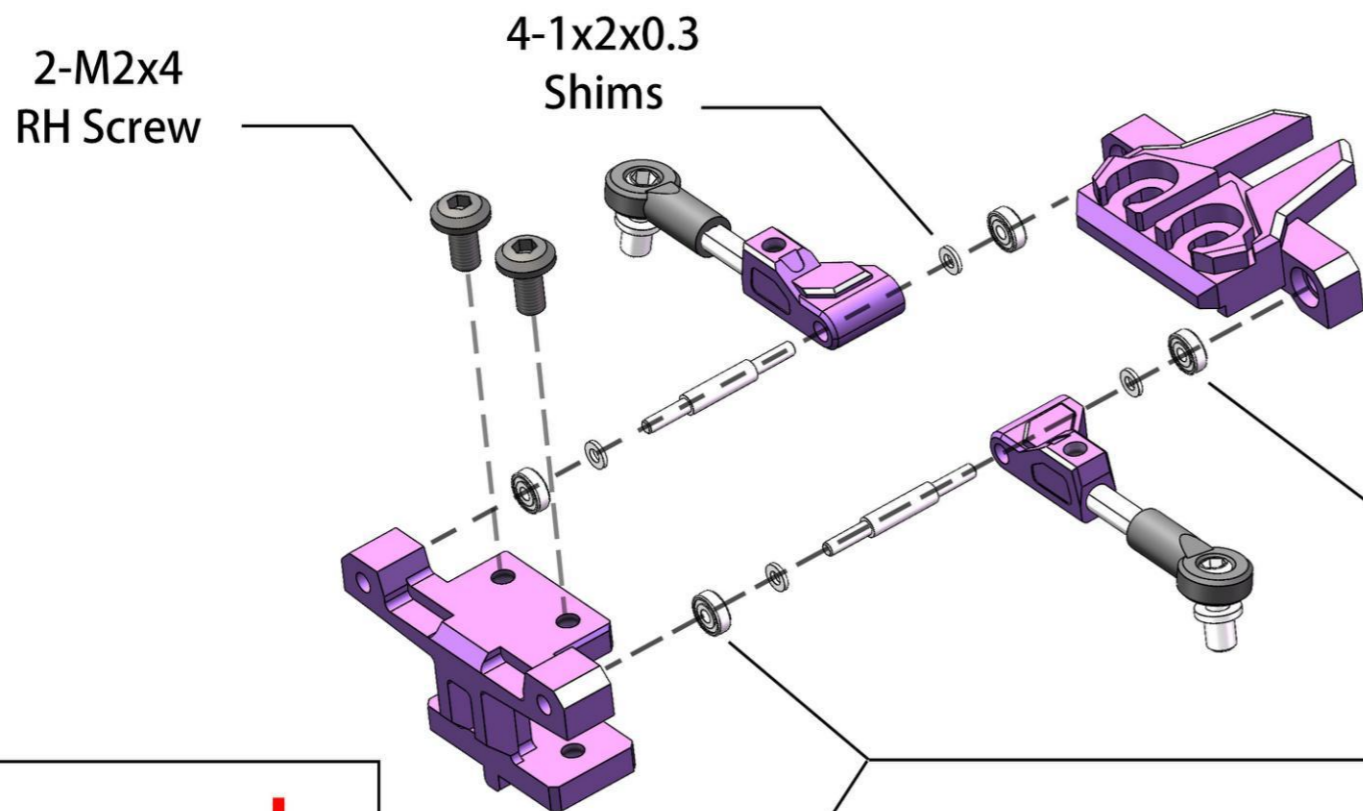

根据实际情况，可以更换或增加 1x2x0.1 垫片，以顺畅为主，尽量减少间隙。

According to the actual situation, 1x2x0.1 gasket can be replaced or added, Mainly smooth and minimize the gap.

4-1x2x0.3
Shims

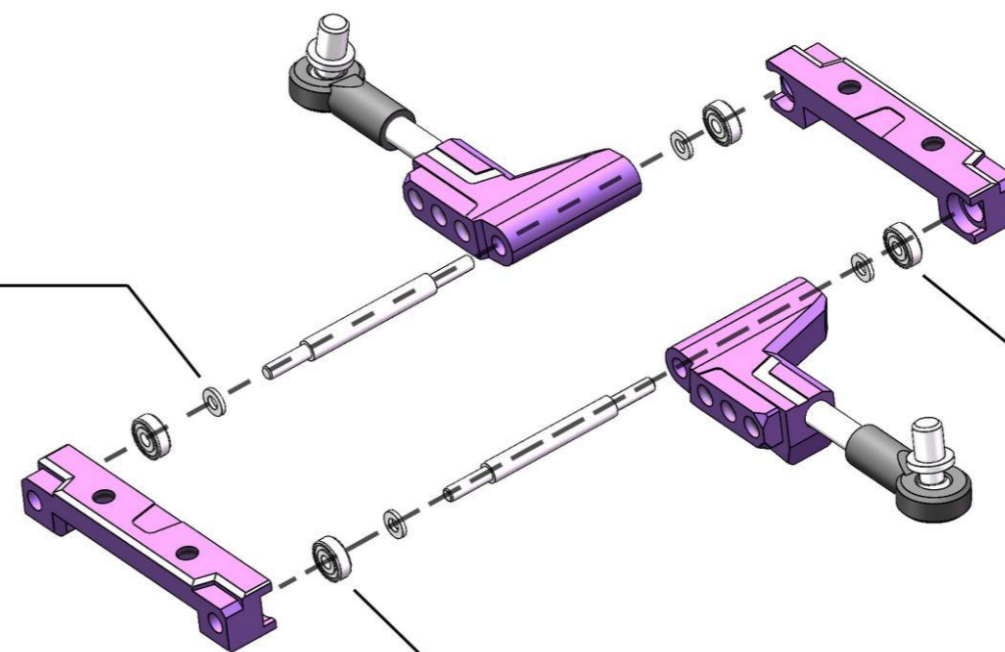

4-1x3x1
Bearing

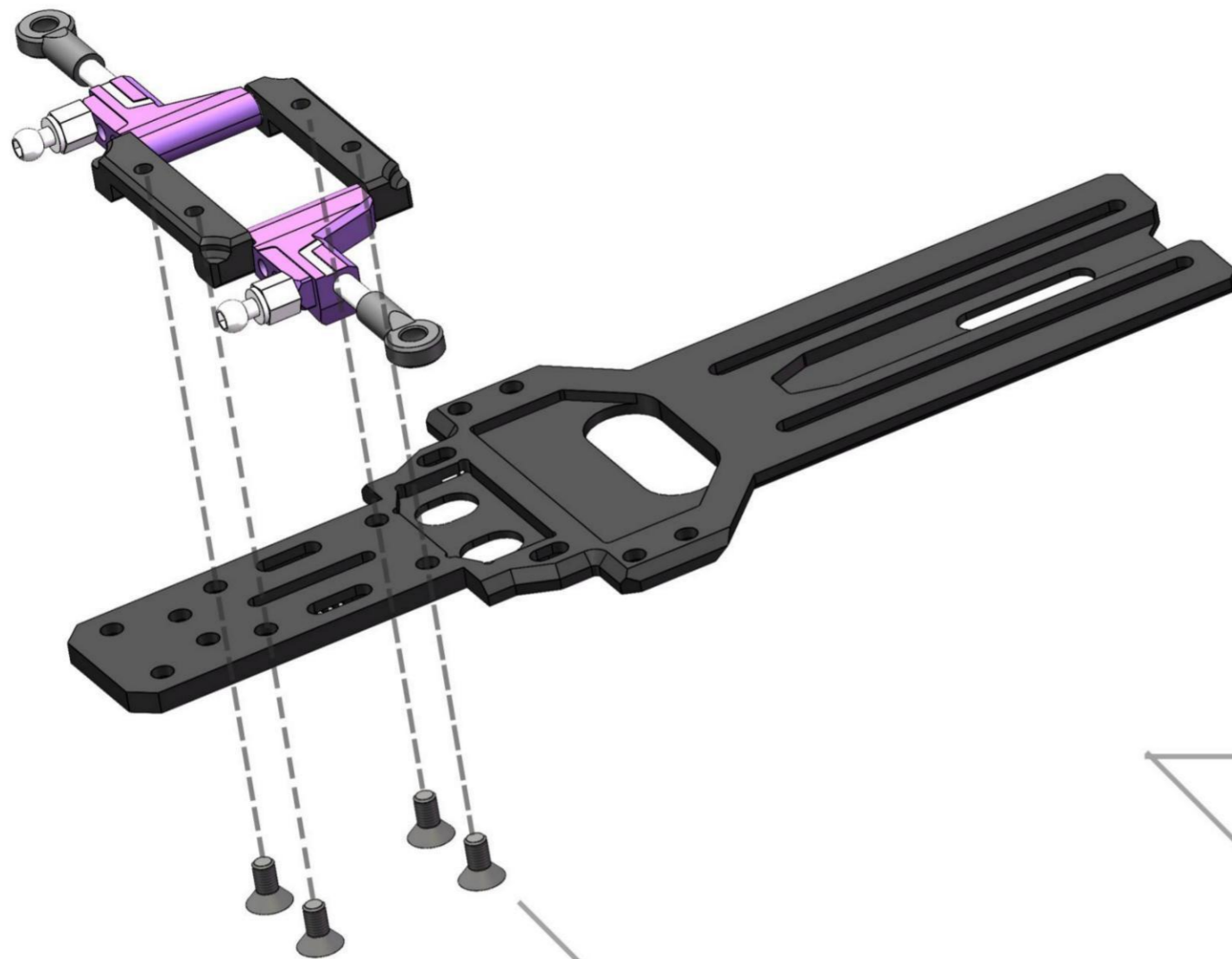

4-M2x4
CS Screw

以顺畅为主，用垫片调整最小间隙
Mainly smooth, and adjust
the minimum clearance with shims

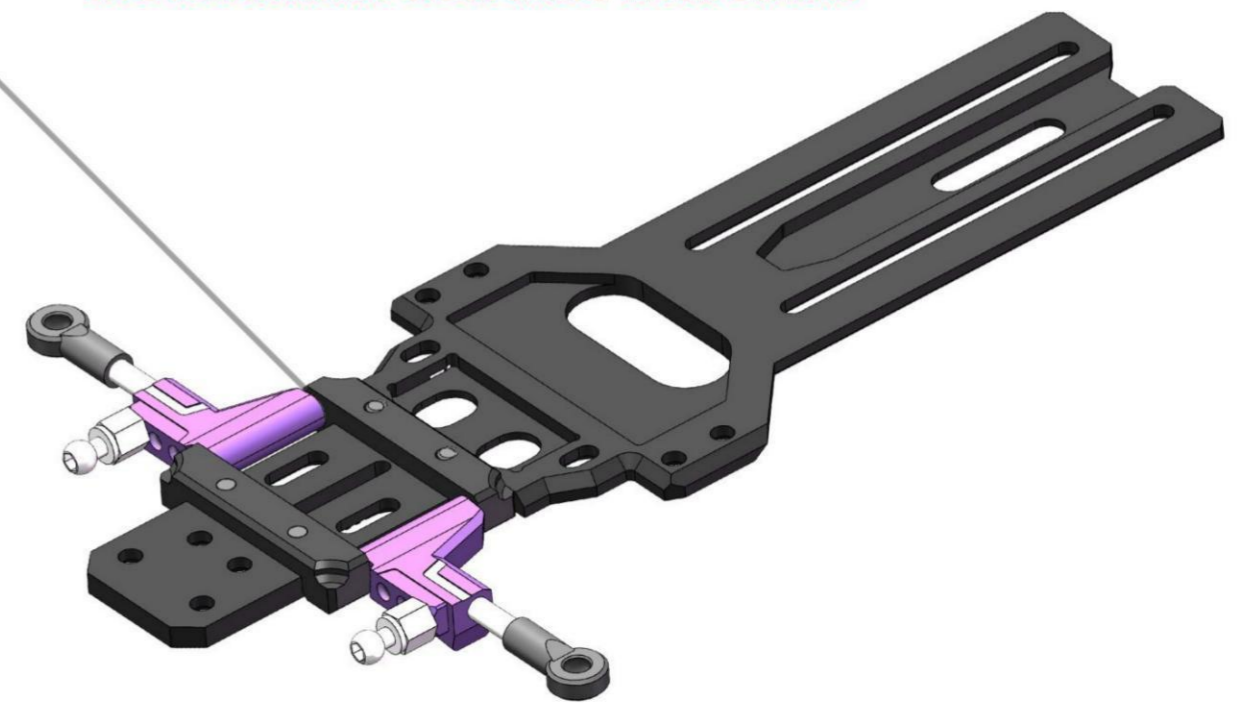

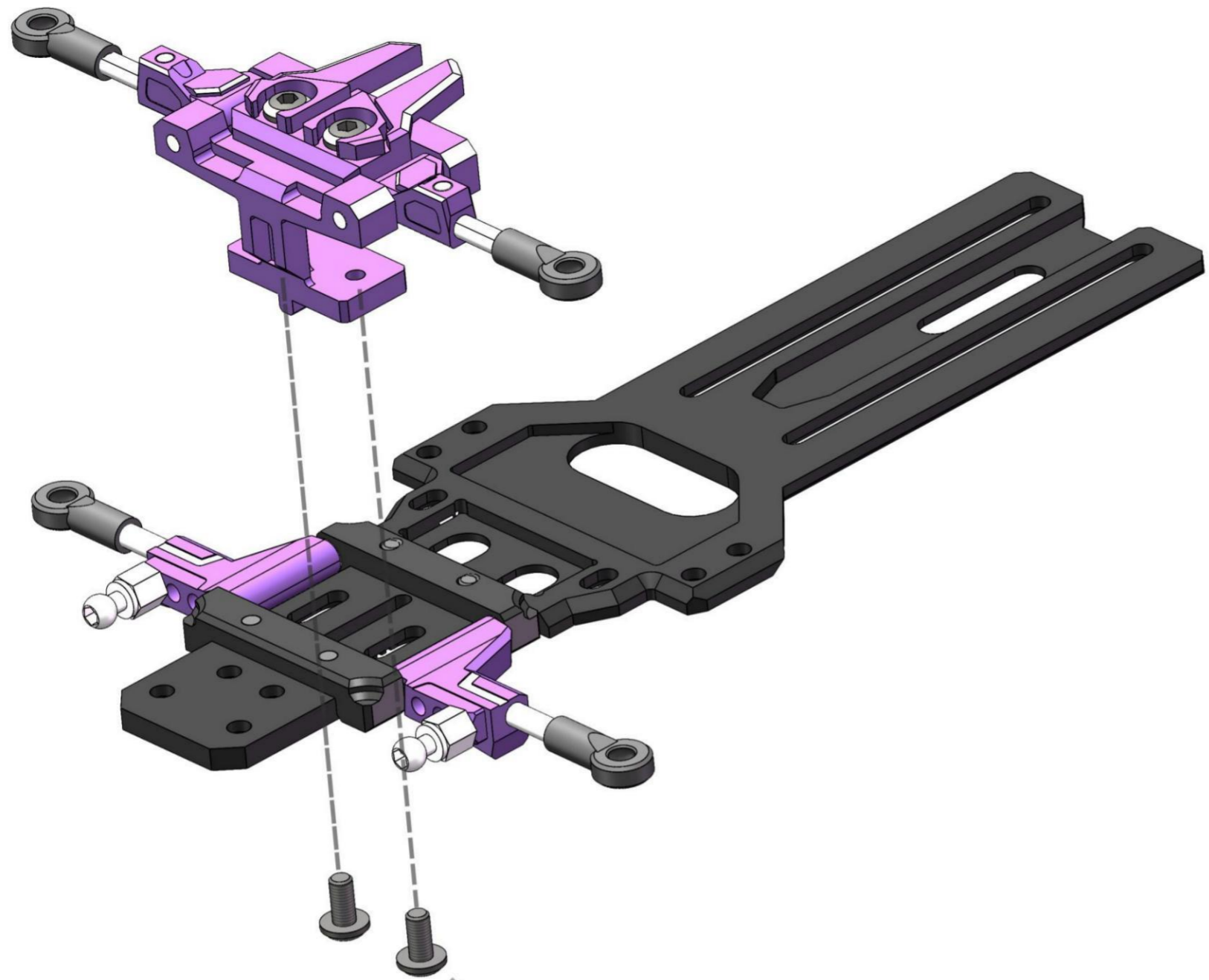

2-M2x4
RH Screw

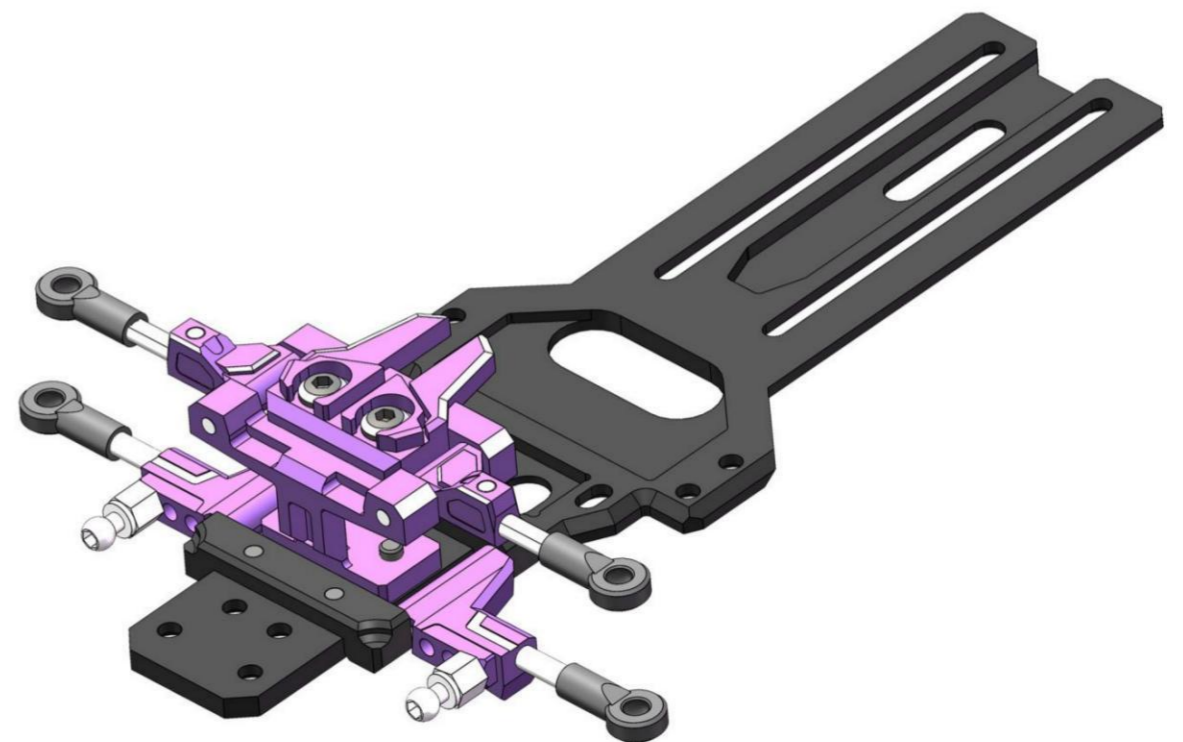

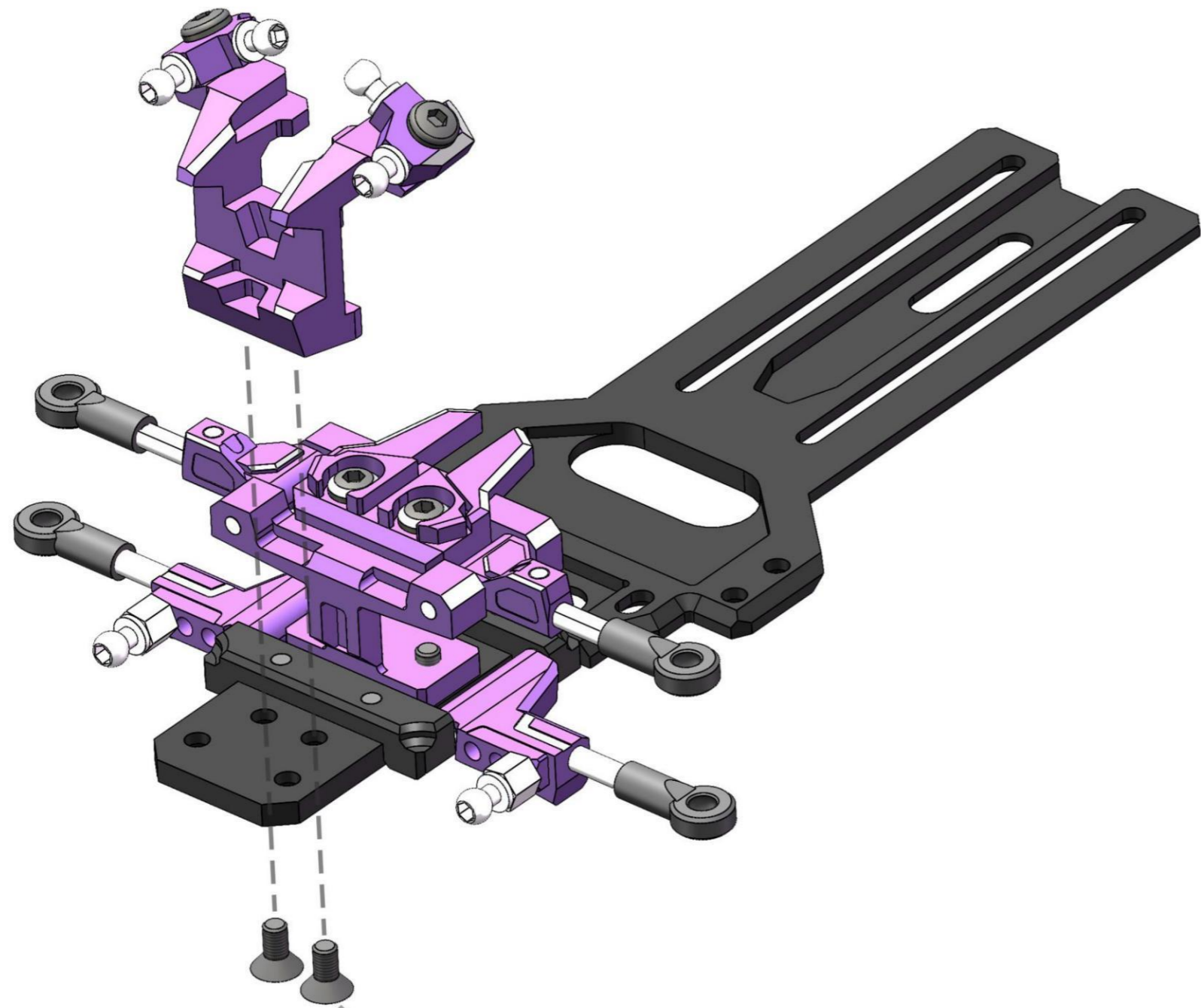

2-M2x4
CS Screw

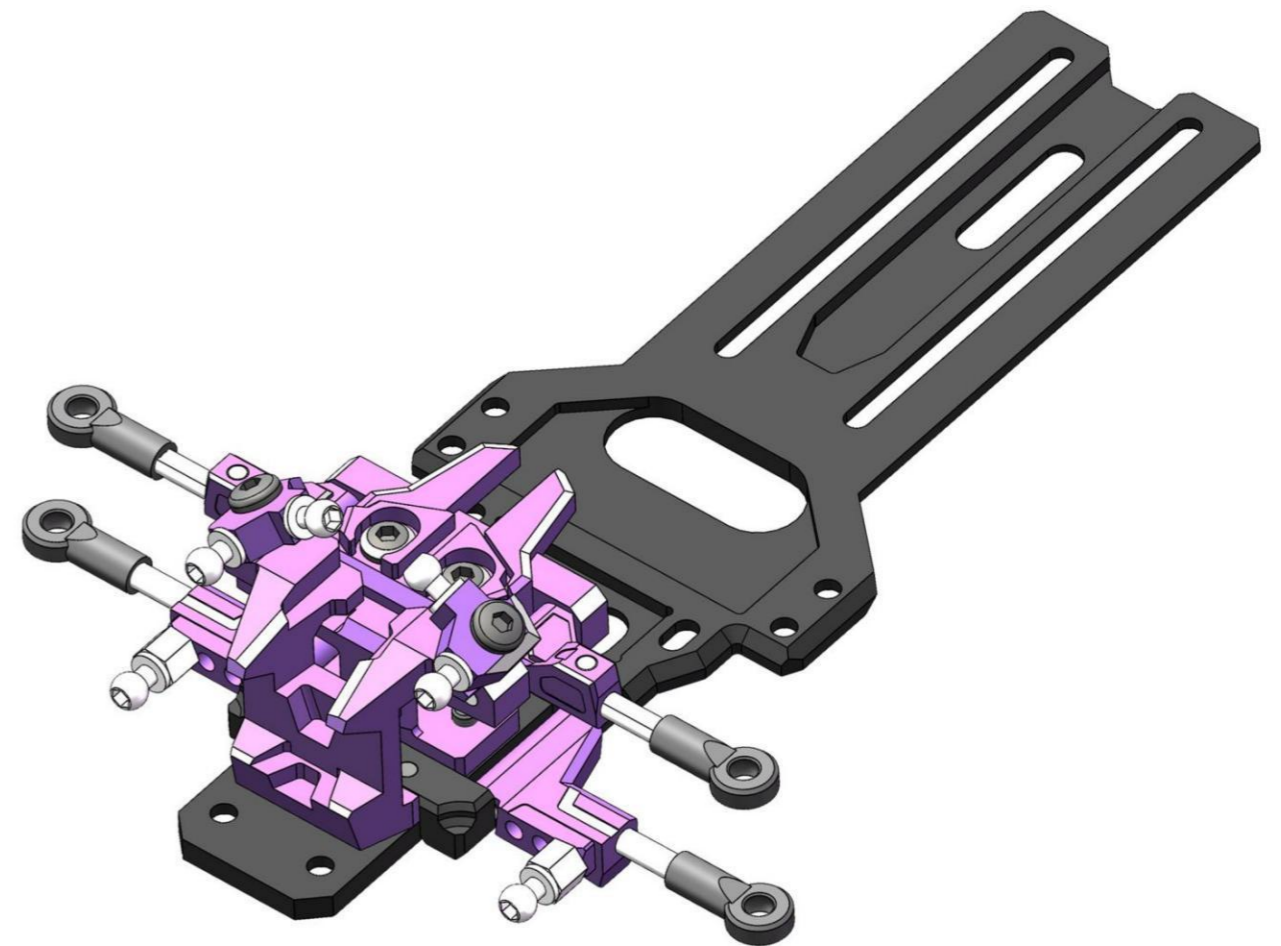

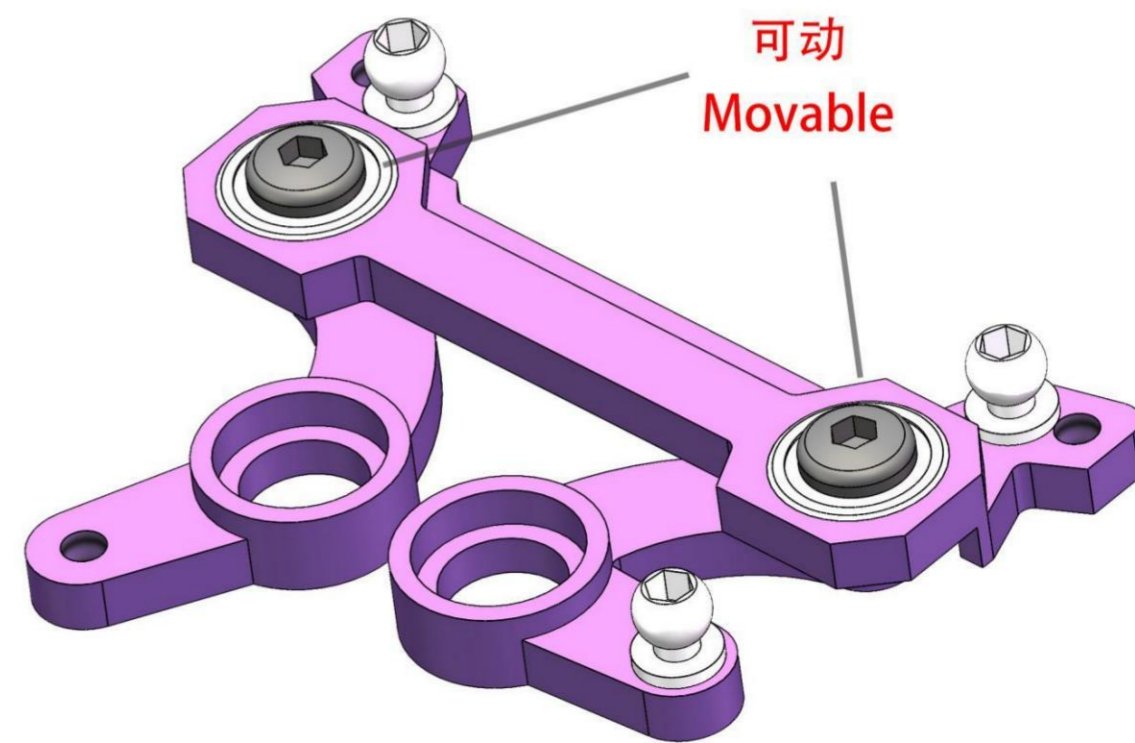
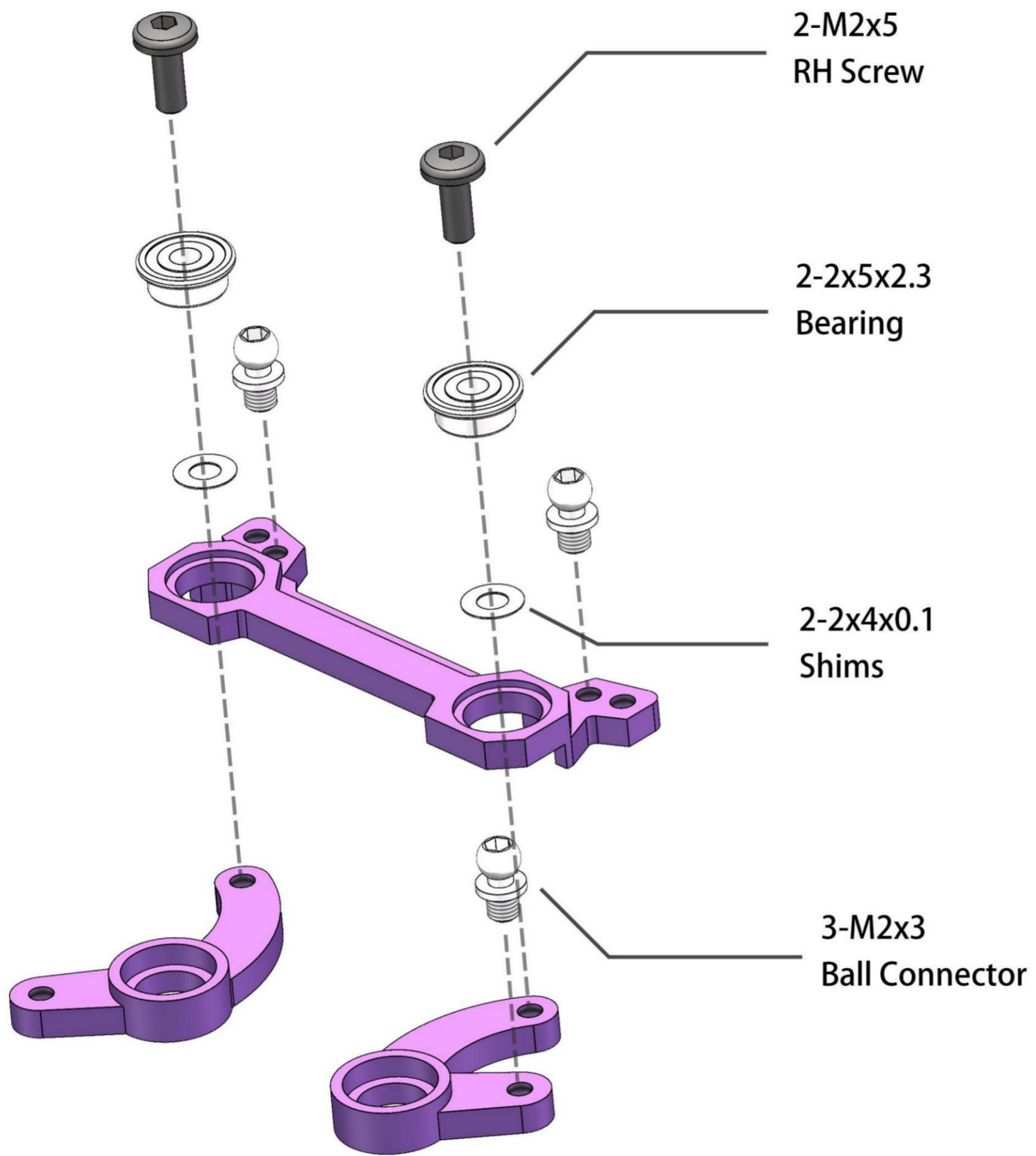

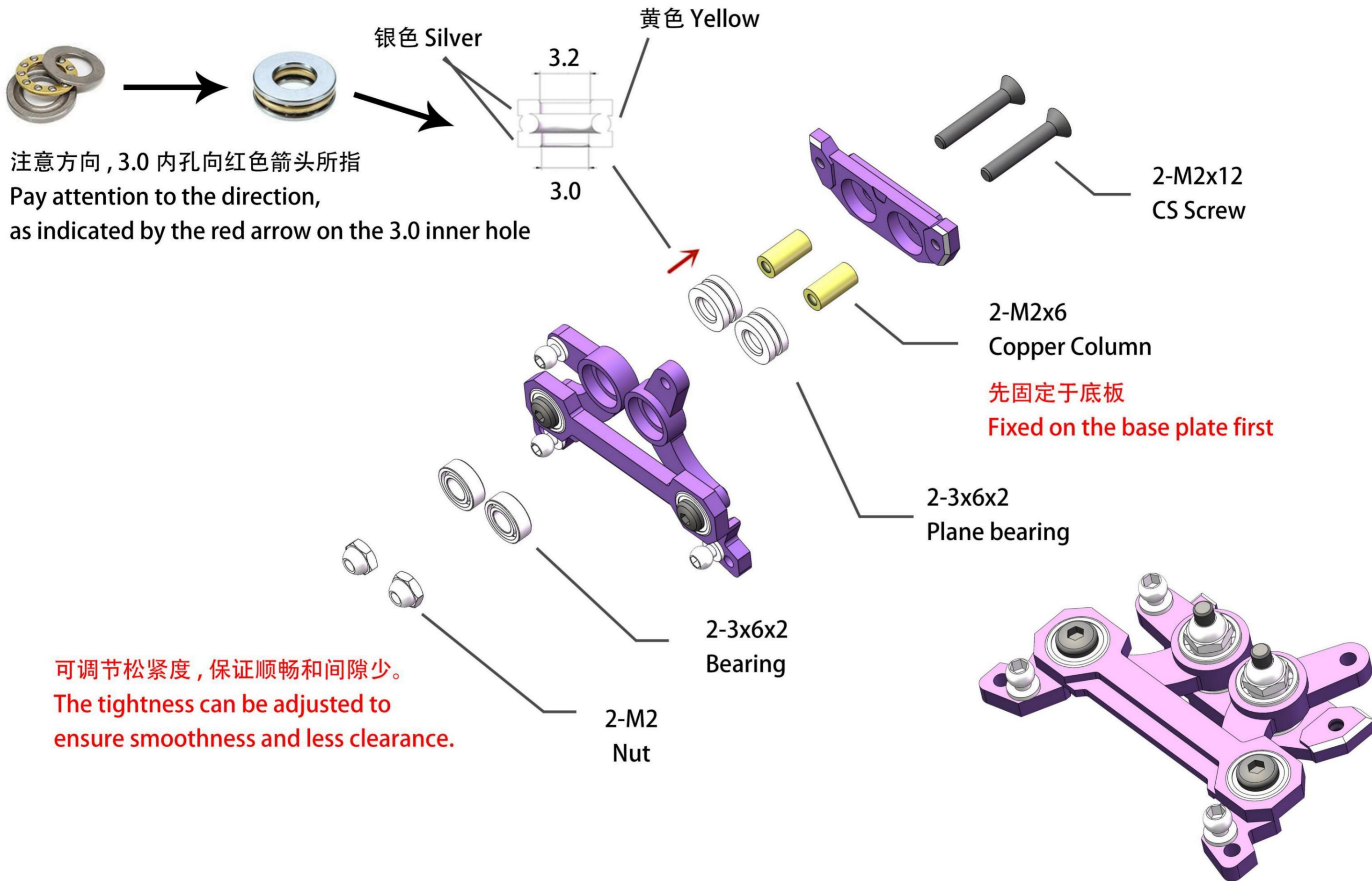

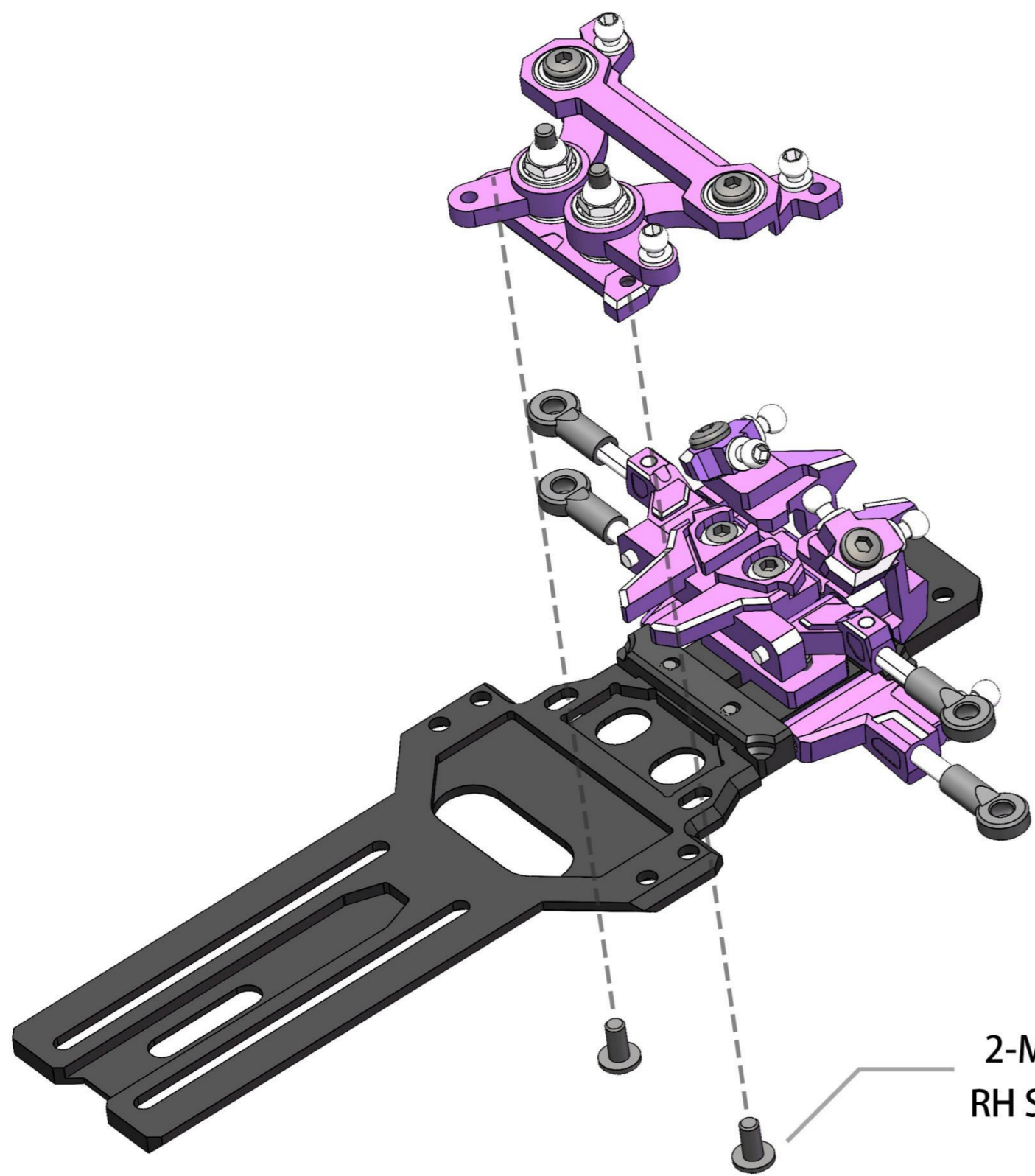

2-M2x3
RH Screw

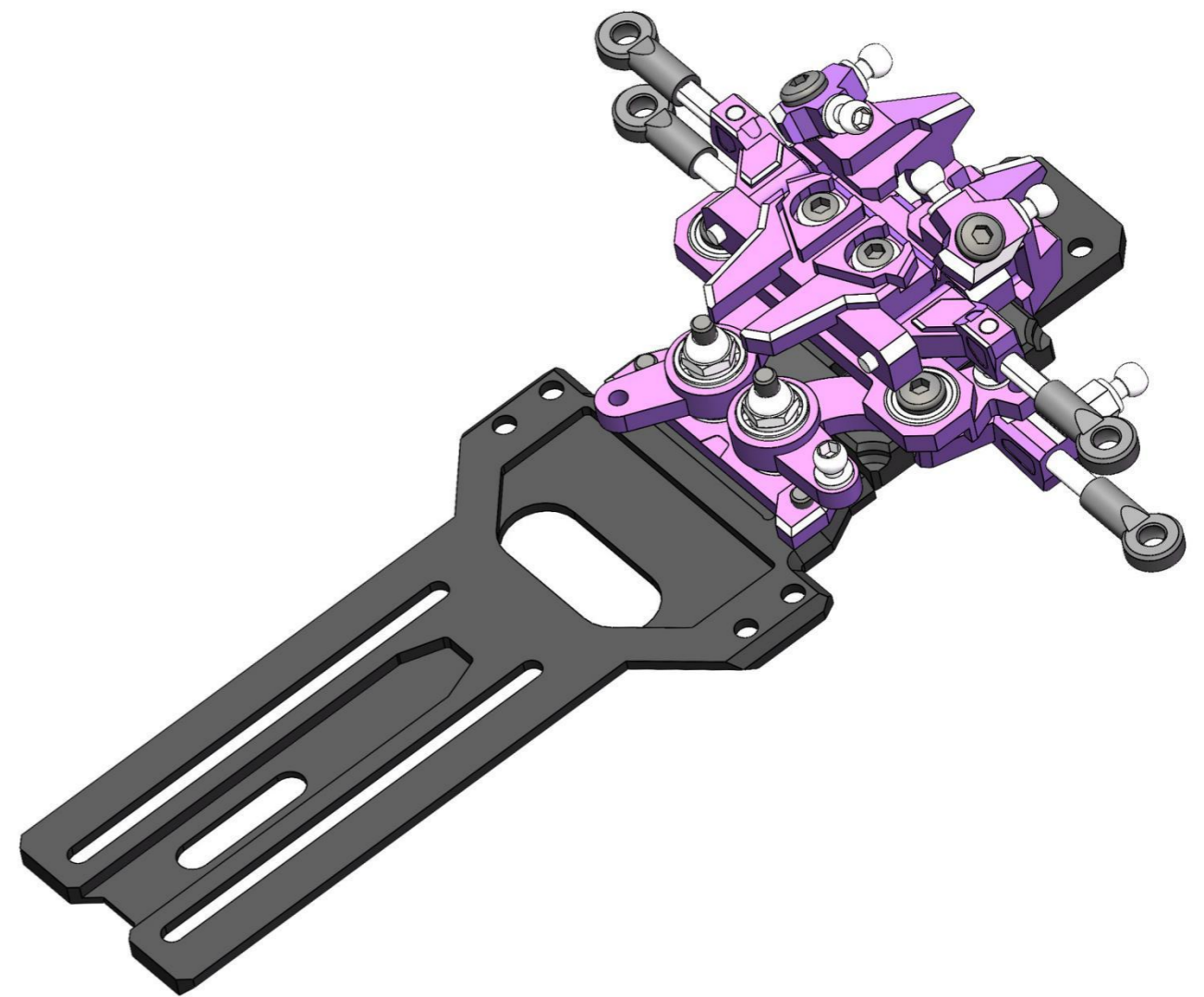

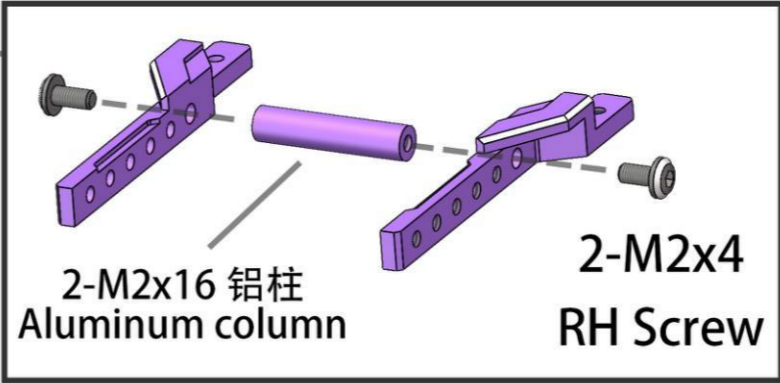
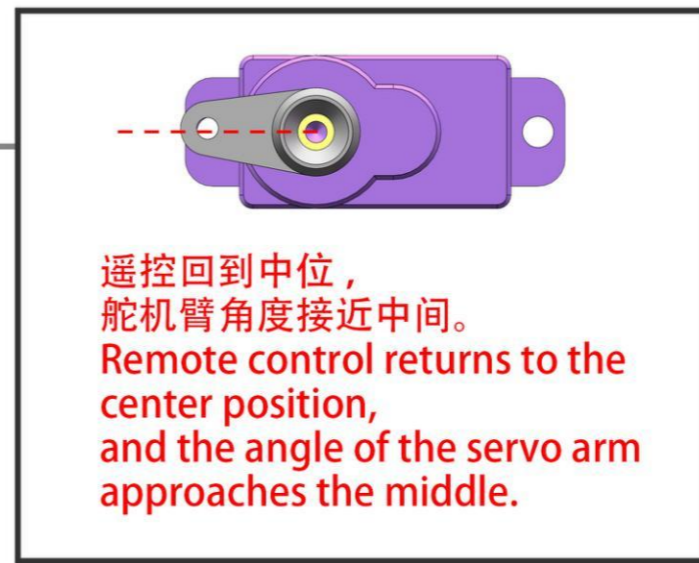
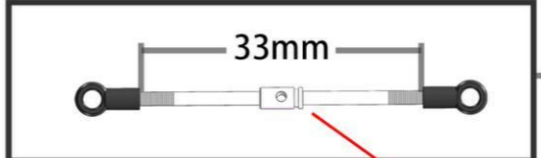
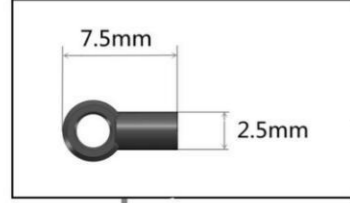
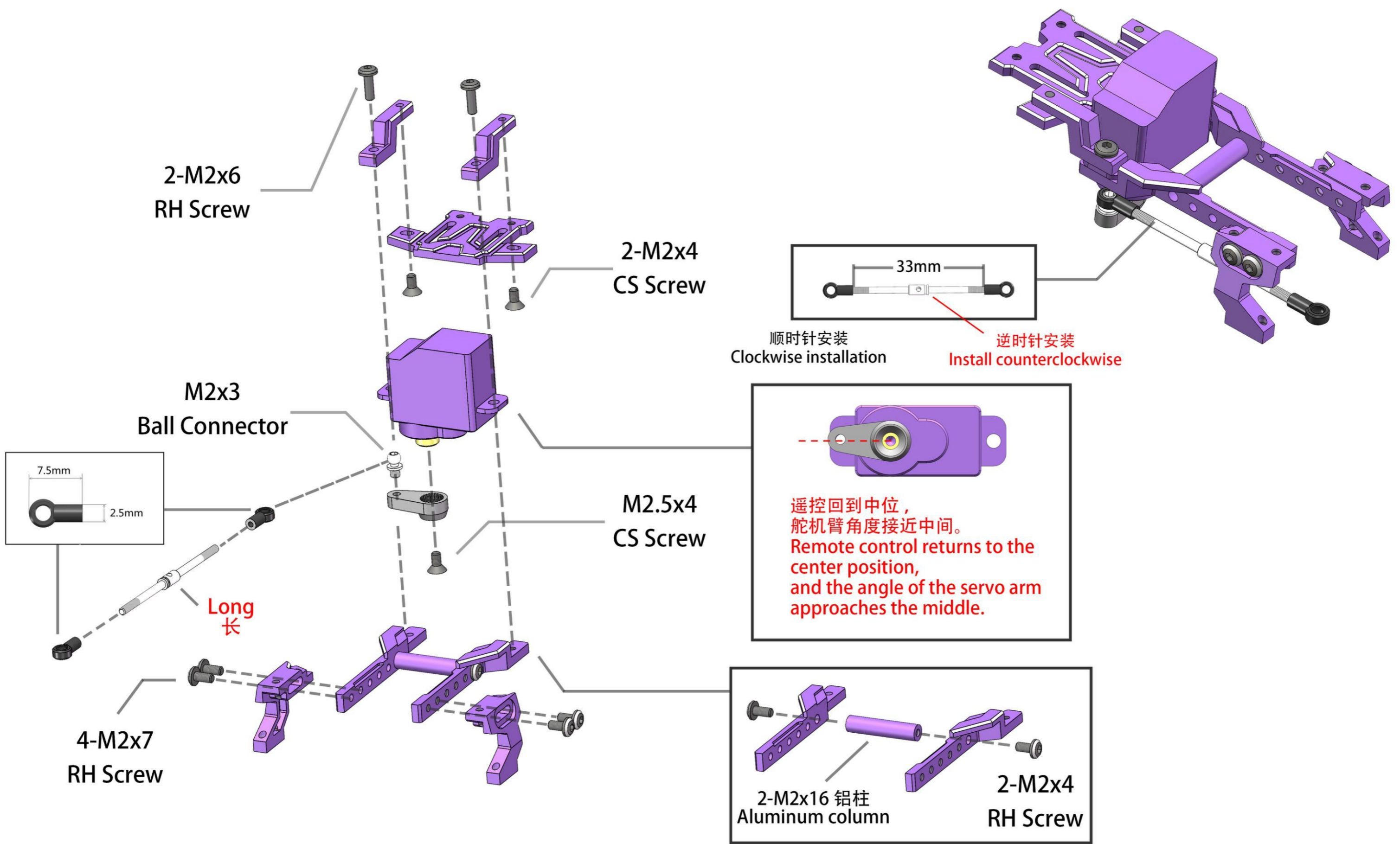

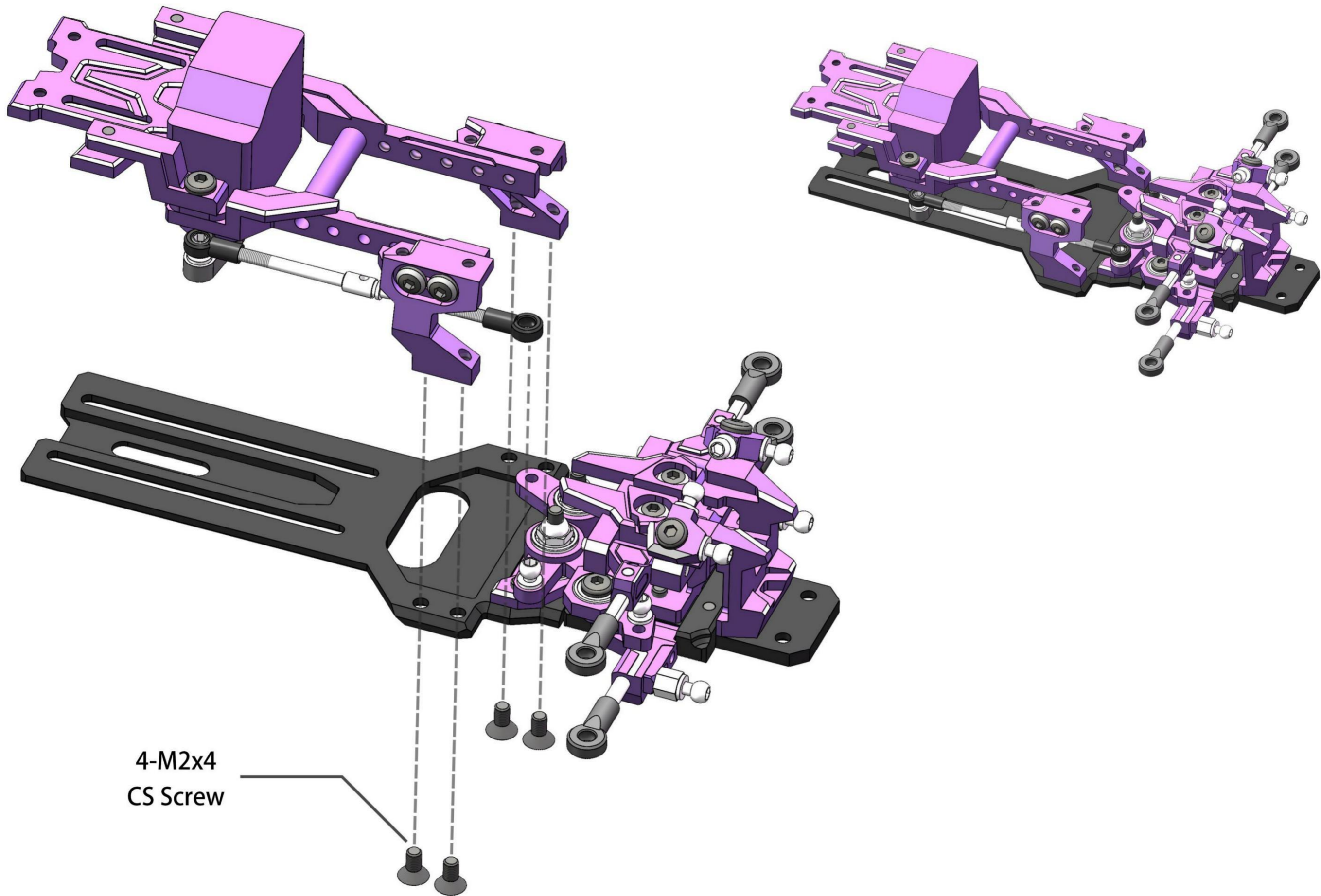

4-M2x4
CS Screw

Front suspension bracket

前避震架

可调整前后位置，使避震一直处于优秀性能的位置
Adjustable front and rear positions to keep
the suspension in an excellent performance position

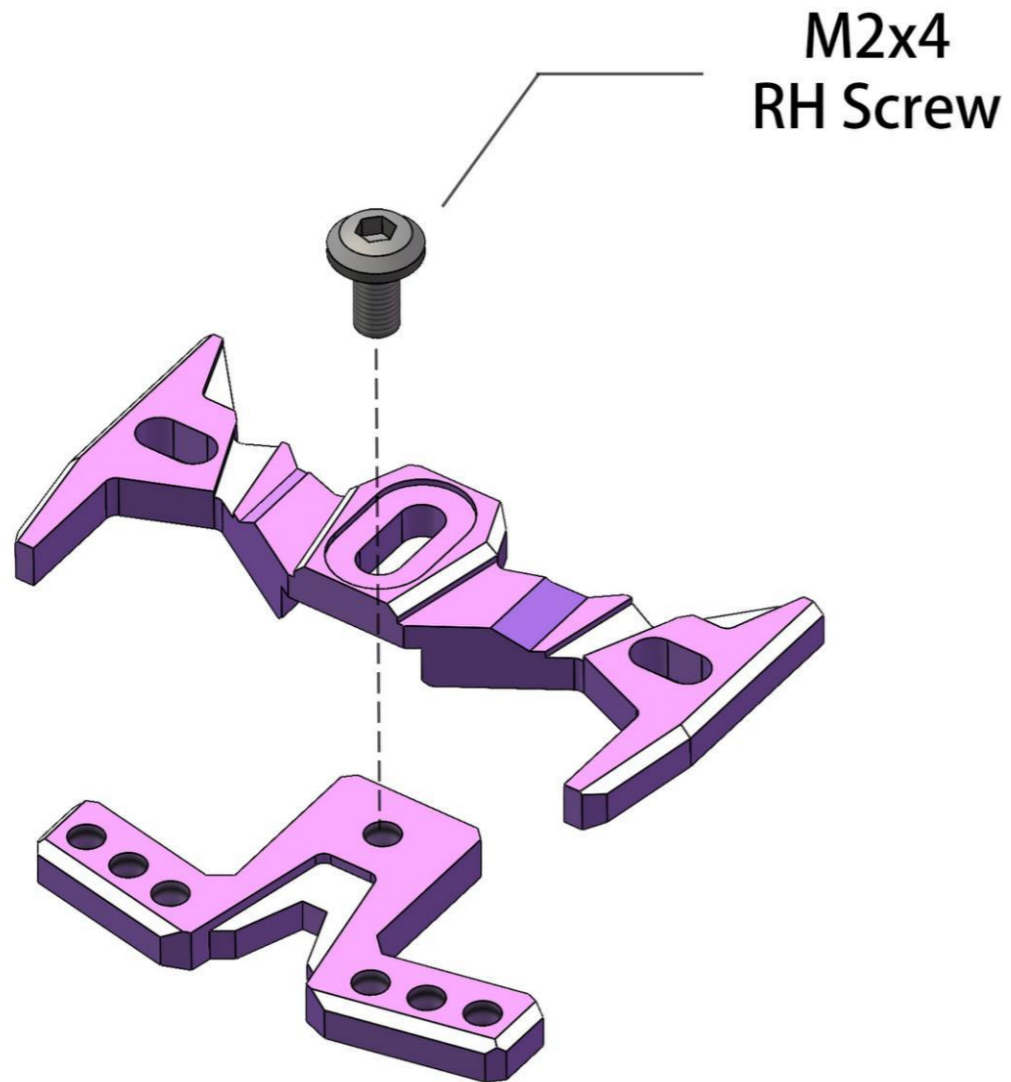

Front and rear limit positions
前后极限位置效果

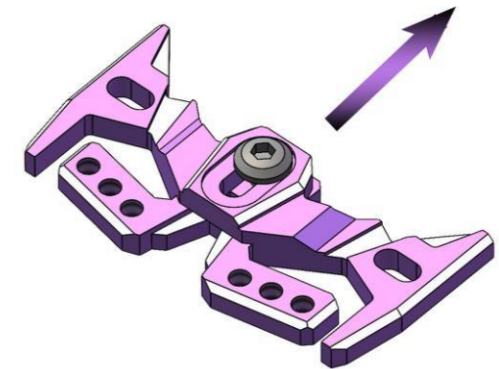

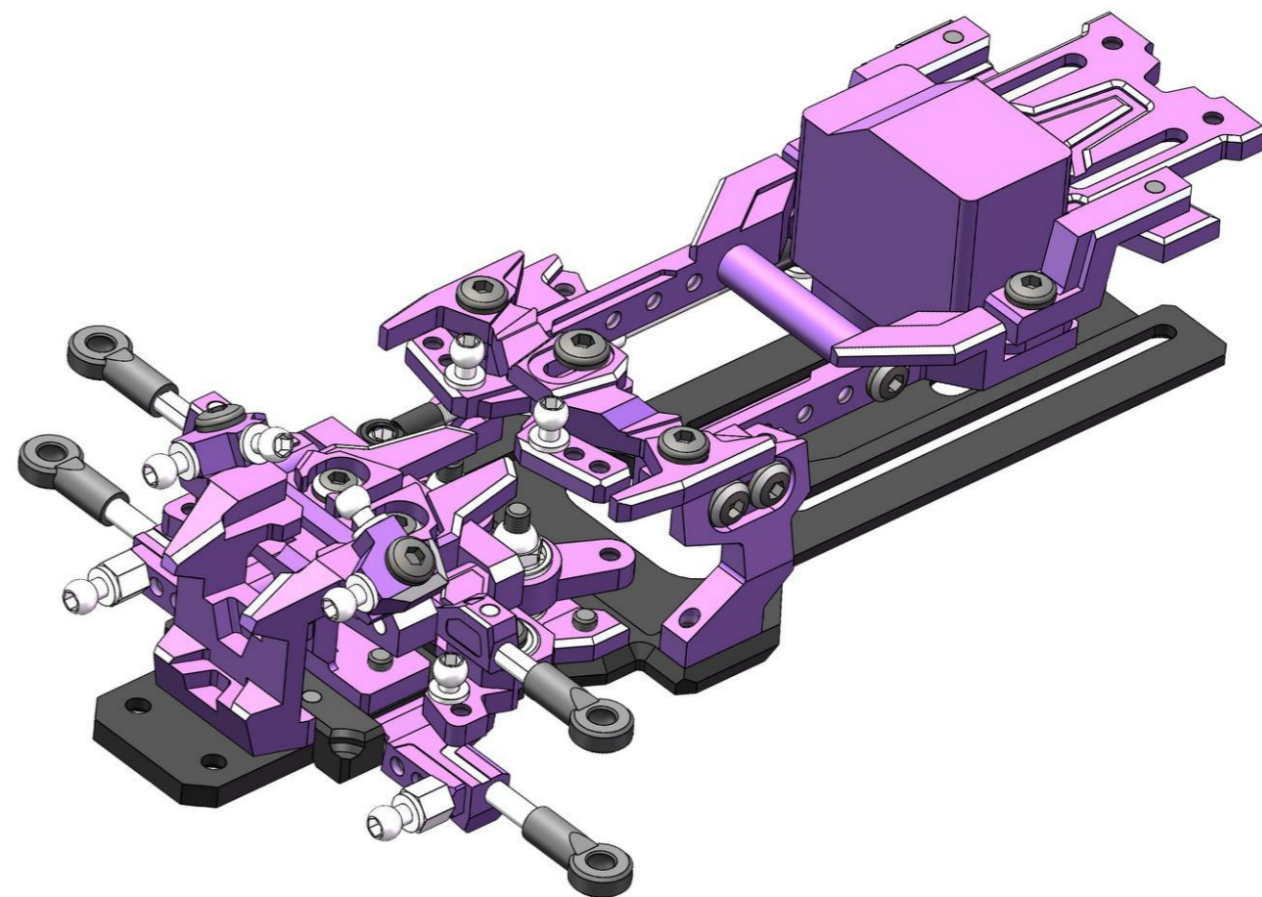
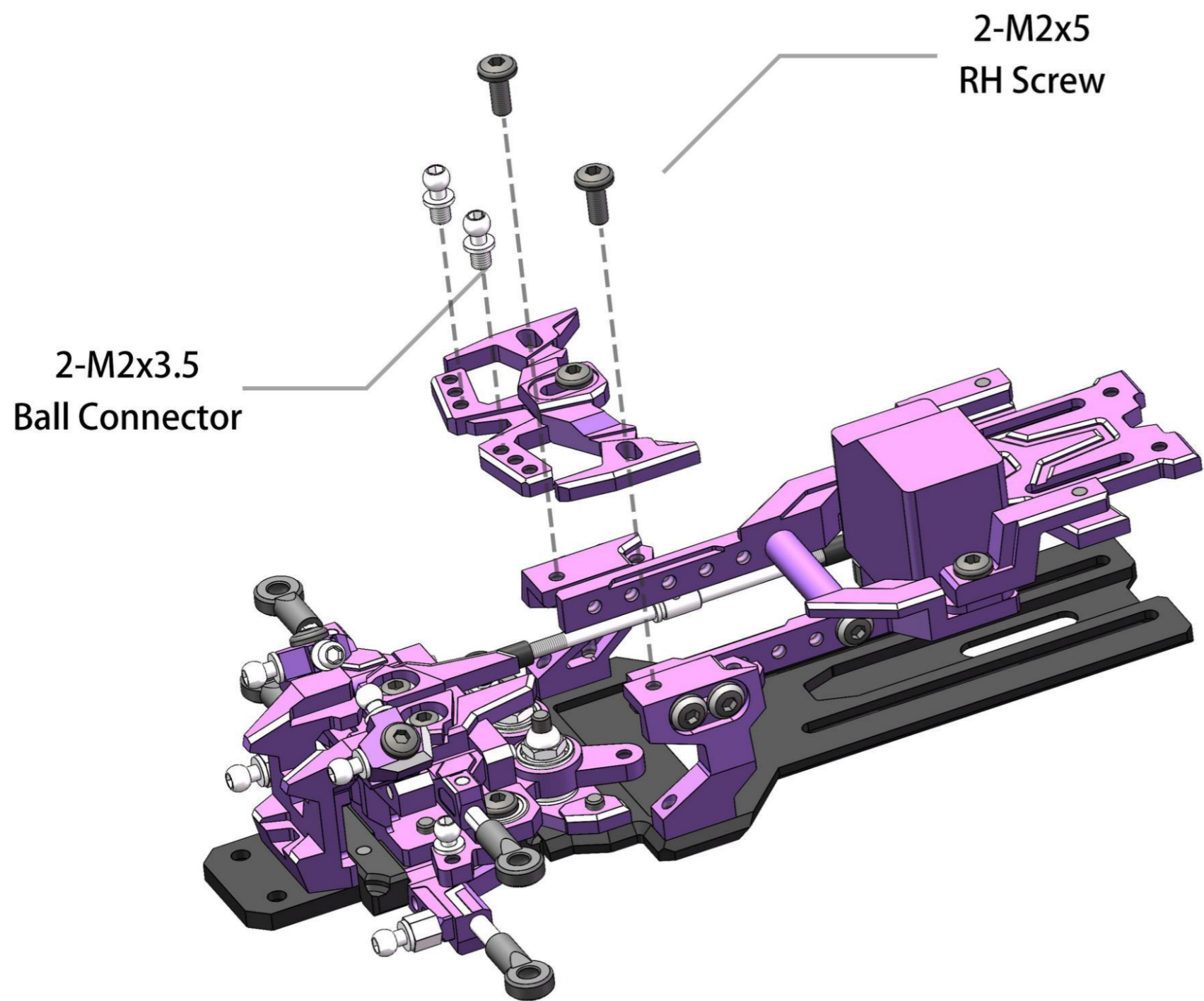

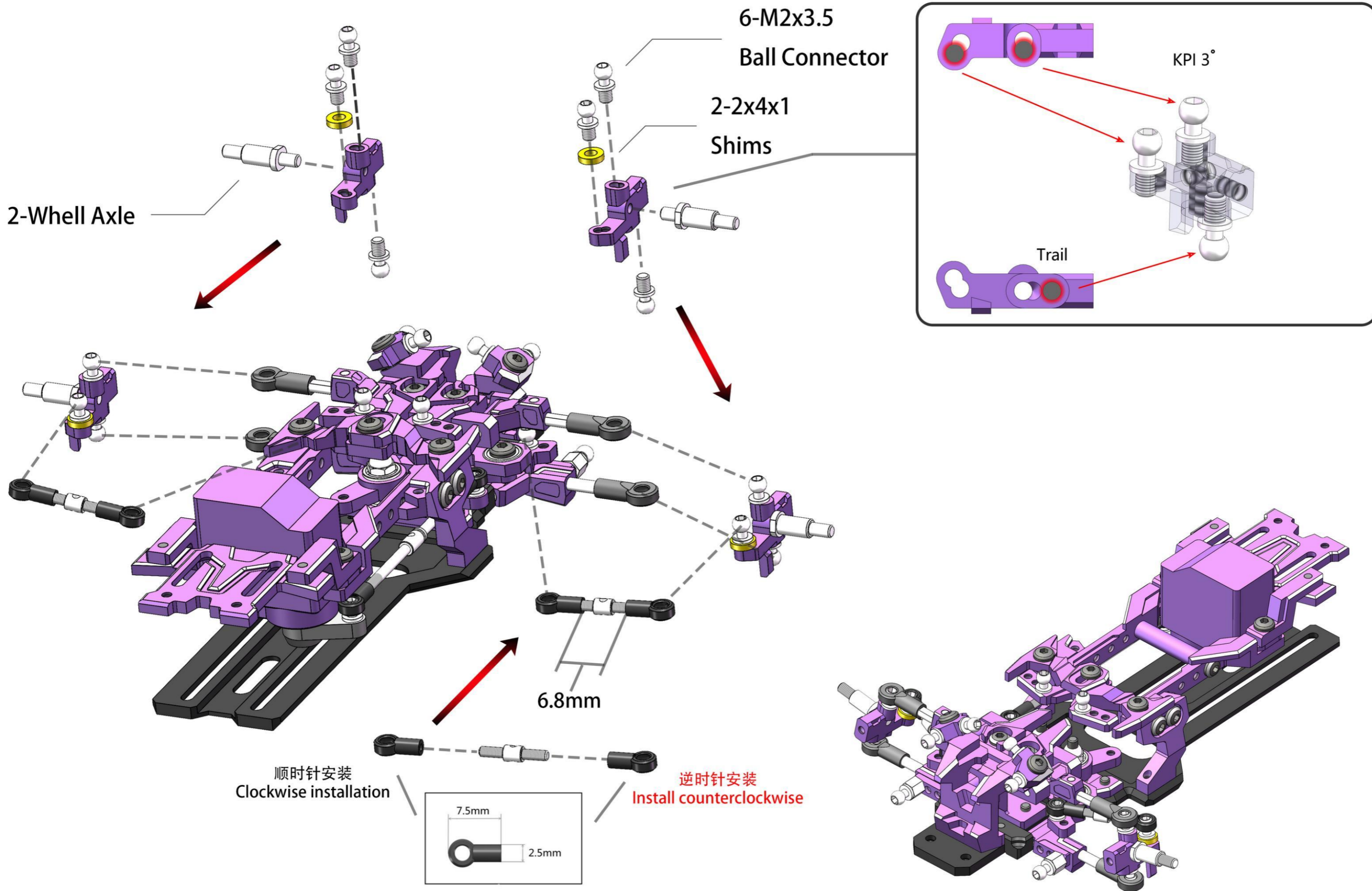

Options Front axle-AWD

OP前轮轴安装-AWD

2-M2x3.5
Ball Connector

4-M2x3
Ball Connector

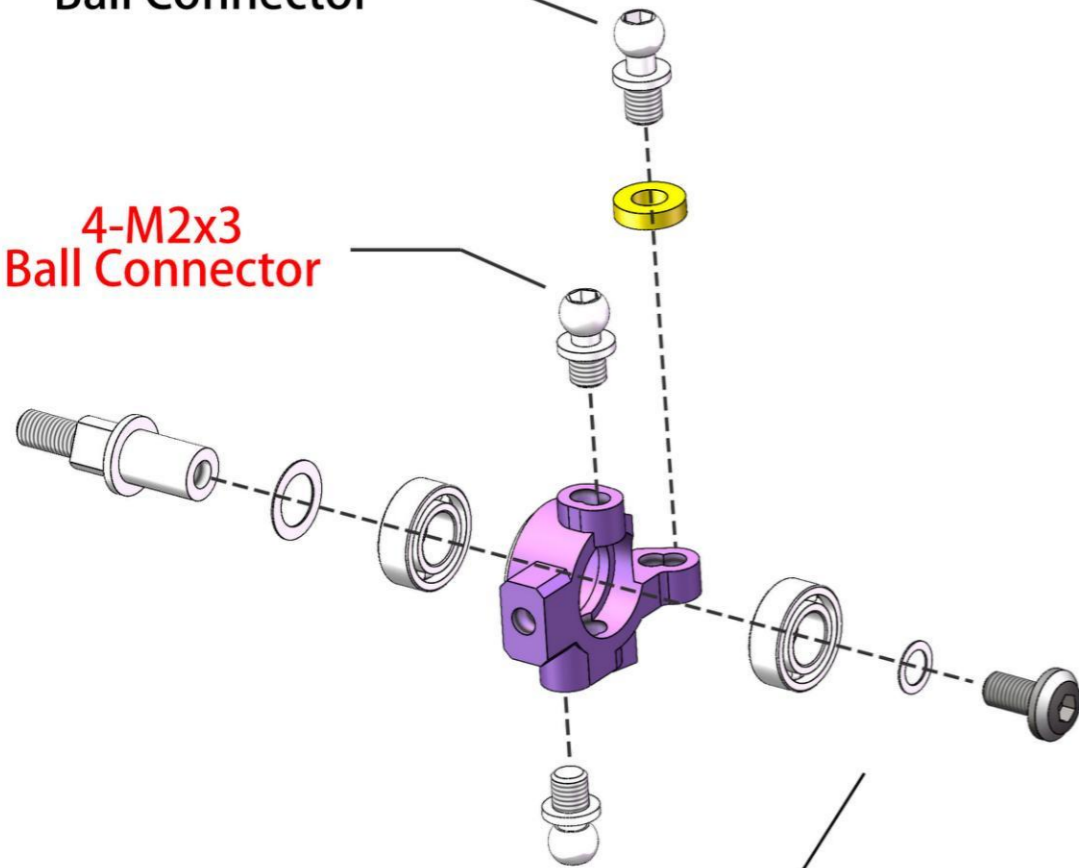

2x3x0.1 or 2x3x0.3
Shims

如果安装后，出现太紧或者太松的情况，
可以调整此如垫片数量。

If there is a situation of being too
tight or too loose after installation,
the number of gaskets can be adjusted.

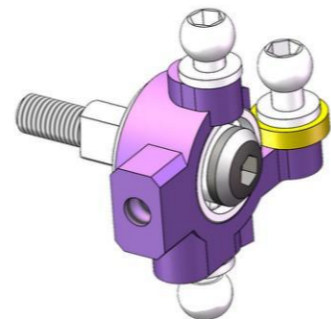

2-2x4x1
Shims

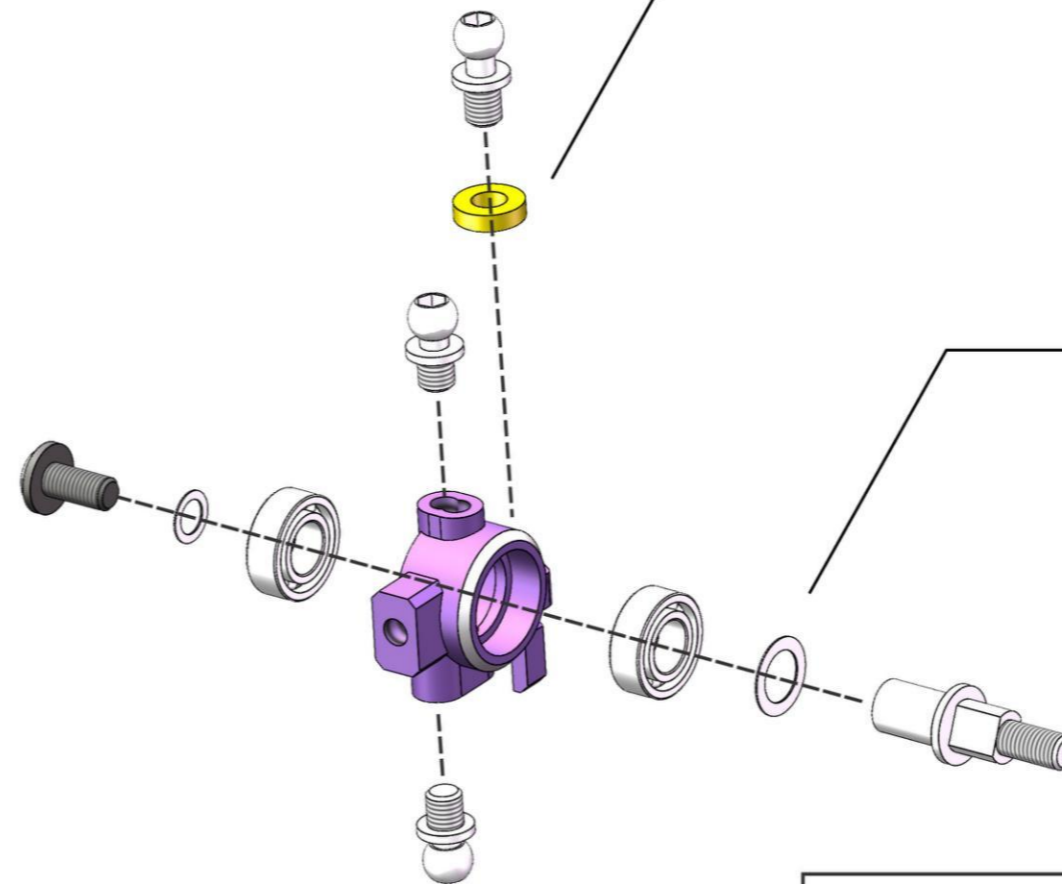

3x4.5x0.1 or 3x4.5x0.3
Shims

如果安装后，出现太紧或者太松的情况，
可以调整此如垫片数量。

If there is a situation of being too
tight or too loose after installation,
the number of gaskets can be adjusted.

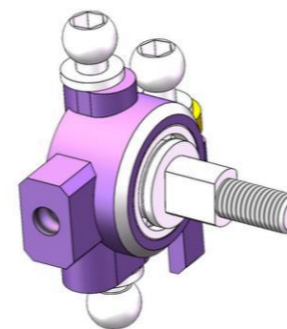

Upward
上方

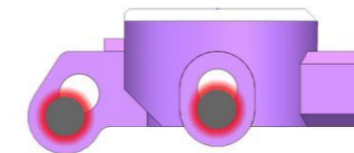

Recommended hole
推荐安装孔位

Downward
下方

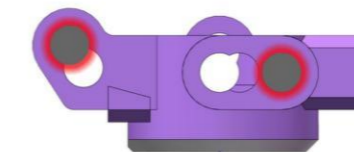

Options metal brake

Front

2. 安装刹车碟
2. Install the brake disc

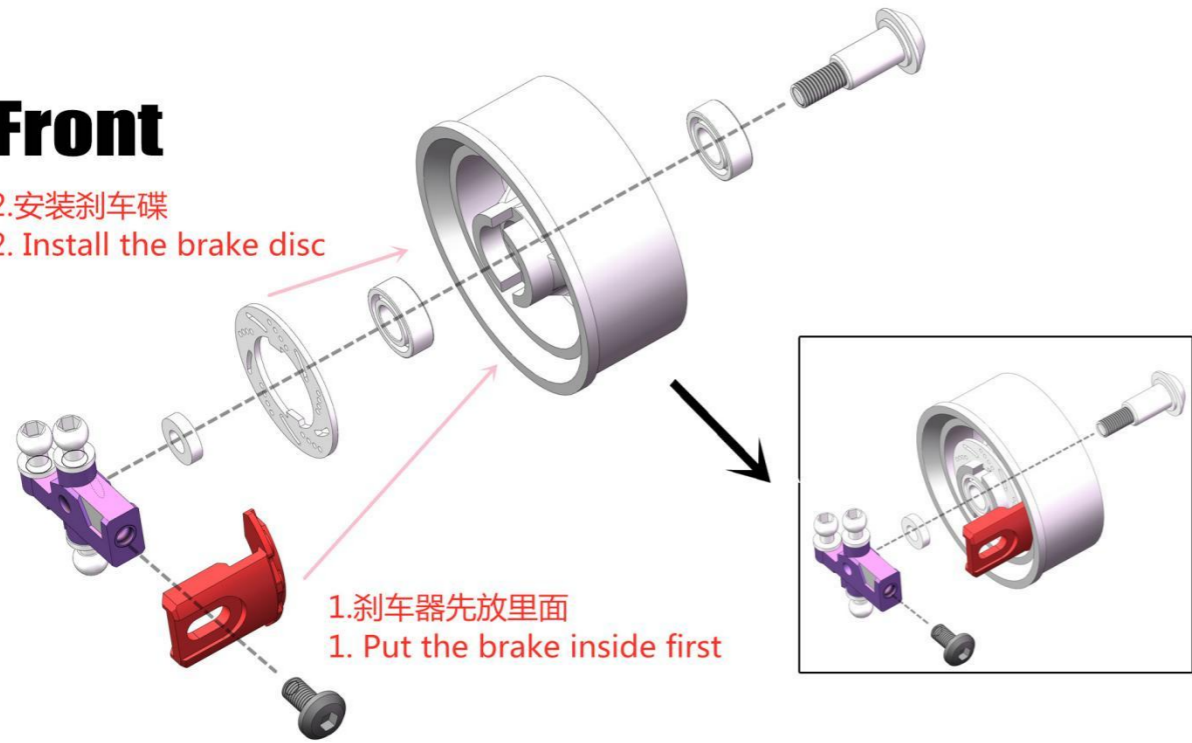

1. 刹车器先放里面
1. Put the brake inside first

1. 根据实际情况，选择安装数量。
2. 先确保零件之间的顺畅度，再尽量减少间隙。
1. Select the installation quantity based on the actual situation.
2. First ensure the smoothness between the parts, and then minimize the gap as much as possible.

Rear

2. 安装刹车碟
2. Install the brake disc

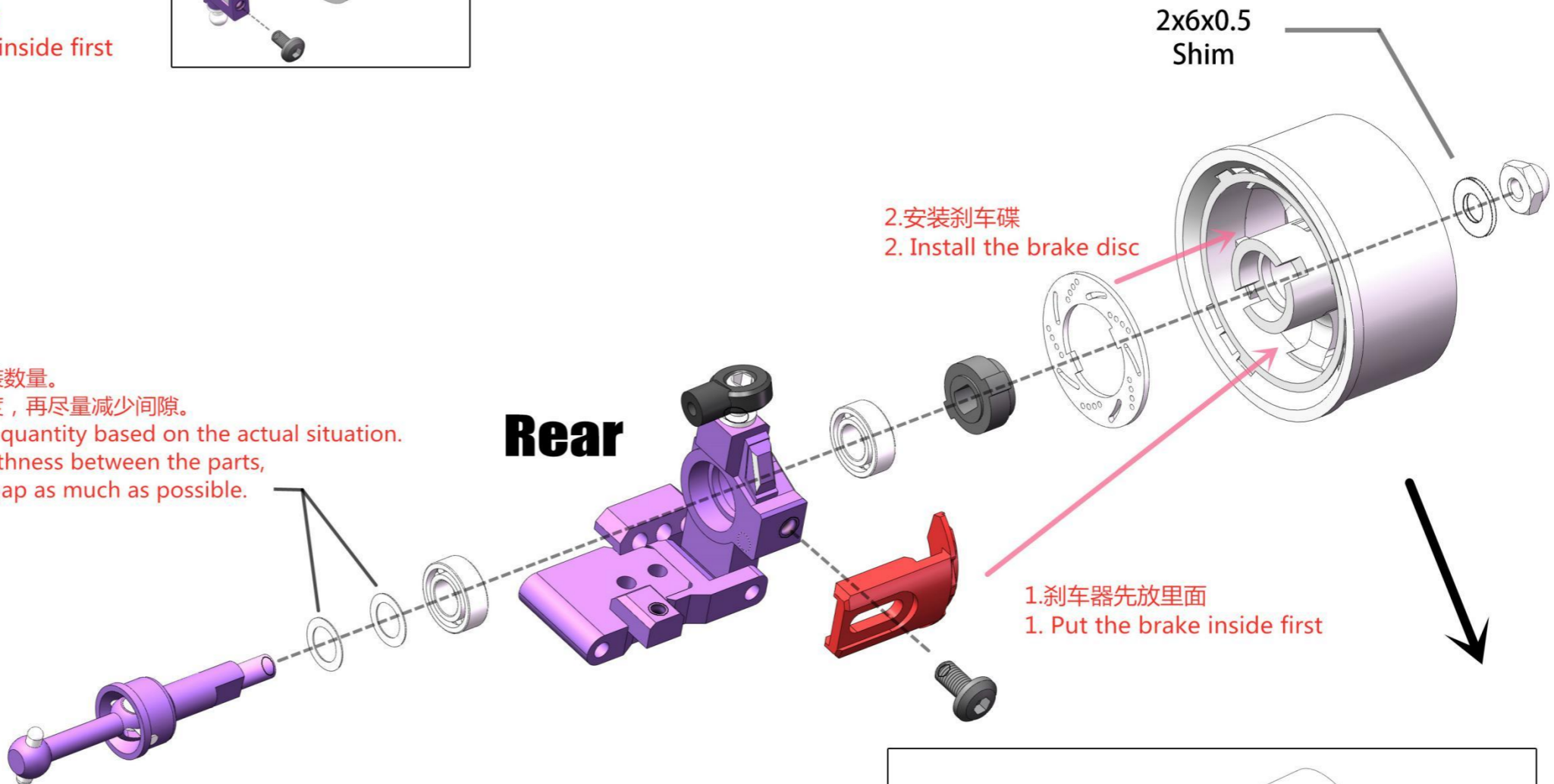

1. 刹车器先放里面
1. Put the brake inside first

1. 先安装。
1. Install first.

2. 后安装。
2. Rear installation.

Optional parts
选装升级配件

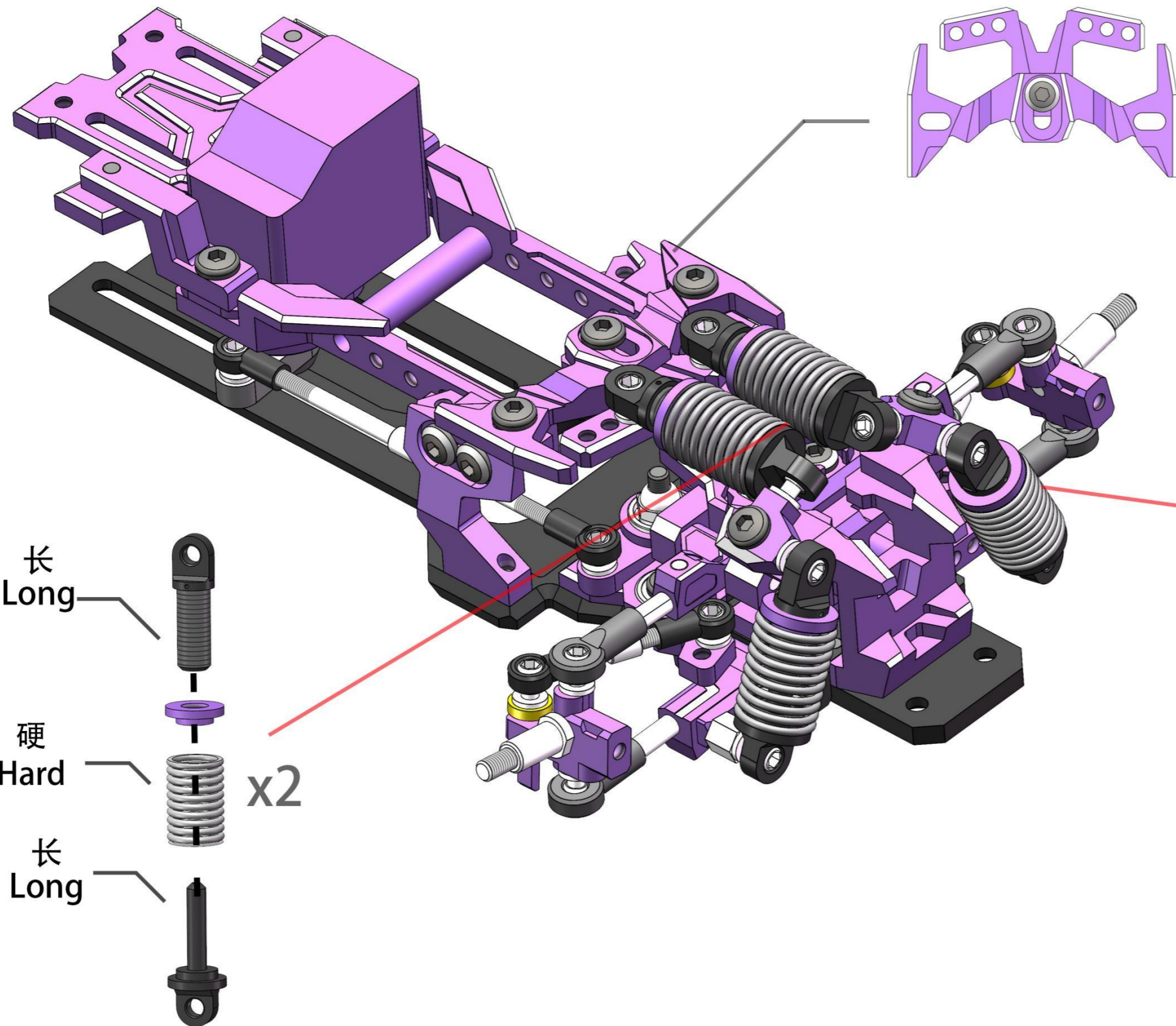

Handle the clamping line of the shock absorber rod to be smooth.
处理避震杆的合模线至光滑

Shock absorber angle effect

1. At the hole position close to the inside, the turn in reaction is fast, and the out turn points to the outside.
2. At the hole position close to the outside, the turn in reaction is slow, and the out turn points to the bend.

避震器角度效果

- 1、靠内的孔位，入弯反应快，出弯指向外弯
- 2、靠外的孔位，入弯反应慢，出弯指向内弯

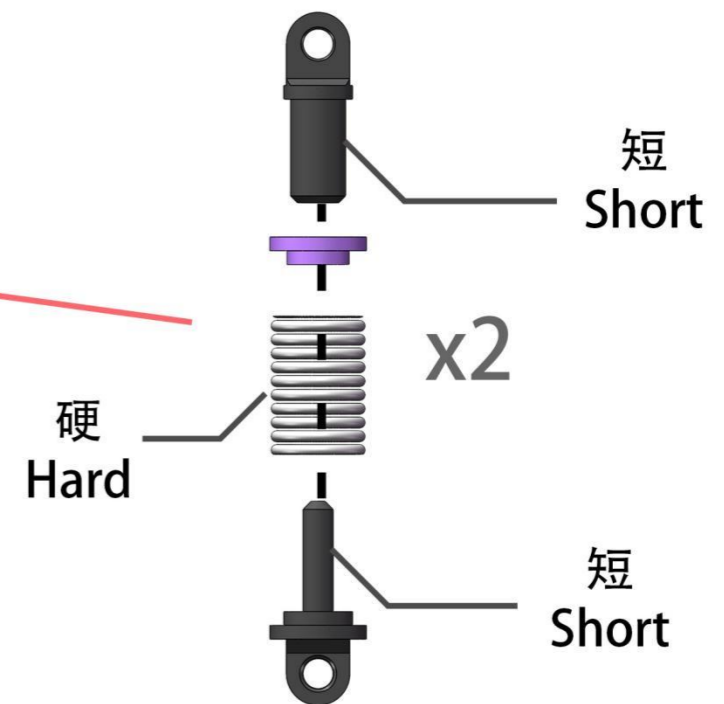

Handle the clamping line of the shock absorber rod to be smooth.
处理避震杆的合模线至光滑



Rear suspended server

后置悬空舵机

Increase pendulum force to enhance overall flight distance.
增加钟摆力，提升整体飞行距离。

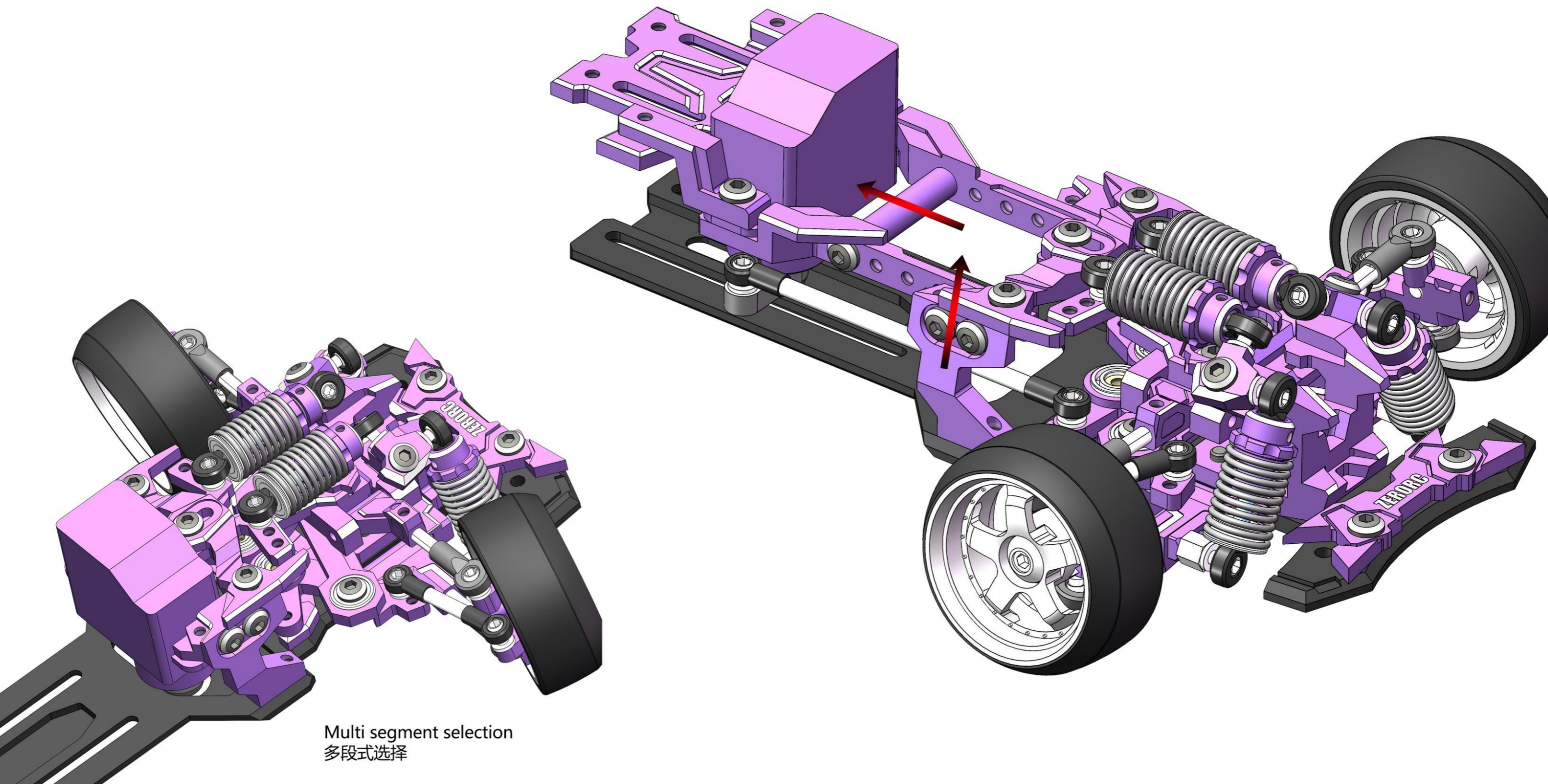

Multi segment selection
多段式选择

Reference data

参考数据

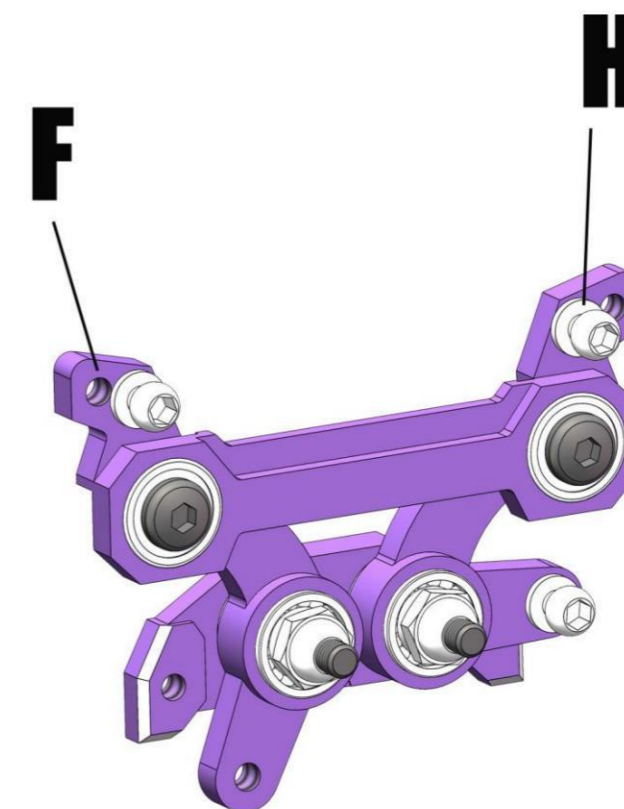
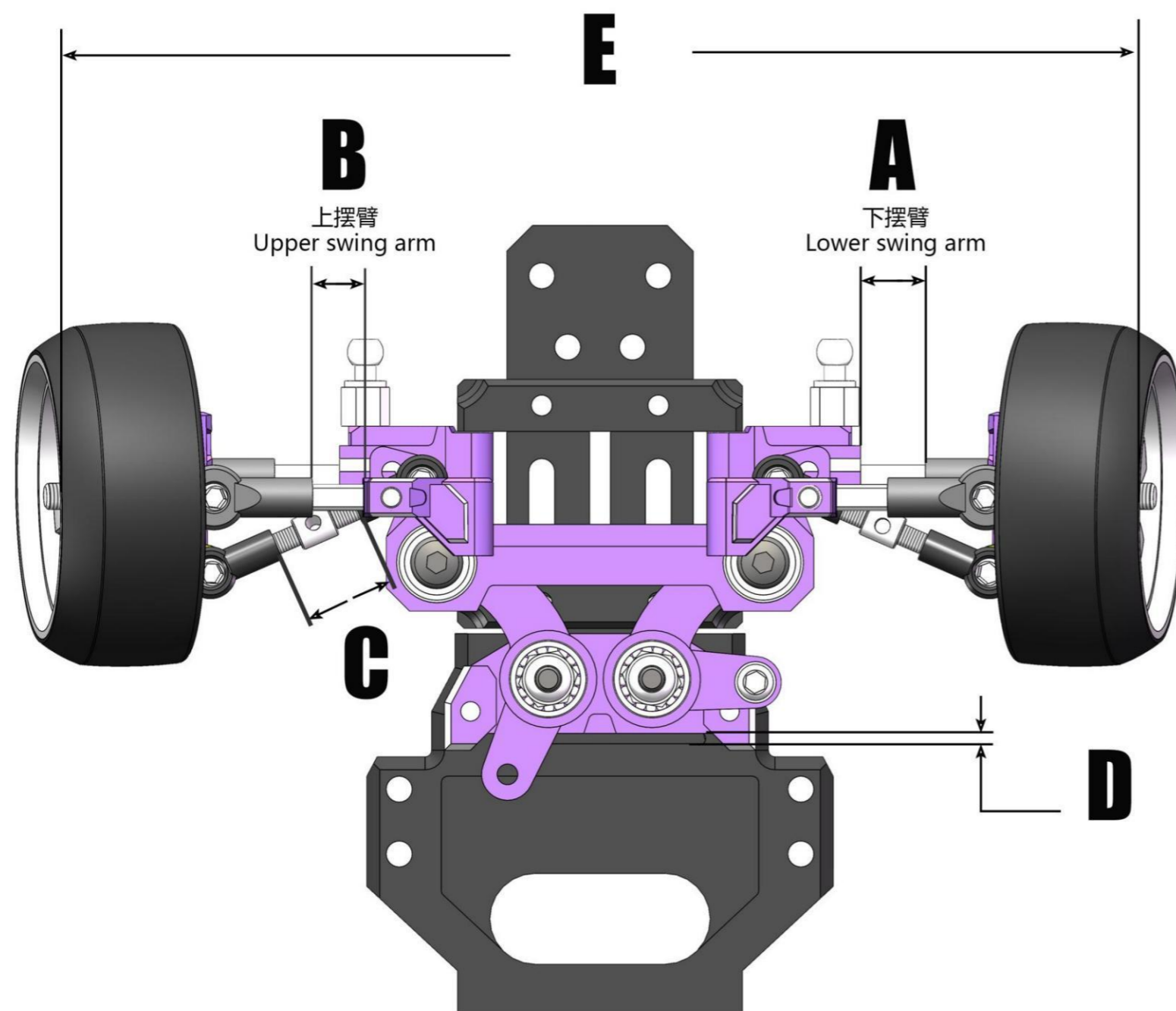

position

孔位置

Choose different positions based on the width of the vehicle.
根据不同车宽，选用不同位置。

No.	Castr	position	Offset	A	B	C	D	E		Remarks
序号	主销后倾	孔位	轮毂度数	下臂长	上臂长	拉杆长 (内长度)	转向滑块 位置 (0-1.5)	窄胎上车宽 Narrow tire	宽胎上车宽 Wide tire	备注
1	7	H	-2	3	2	4.9	0.4	76	79	
2	7	H	-2	4	3	5.9	0.4	78	81	
3	7	H	-2	5	4	6.8	0.4	80	83	Recommend 推荐
4	7	F	-2	6	5	5.8	0.4	82	85	
5	7	F	-2	7	6	6.8	0.4	84	87	

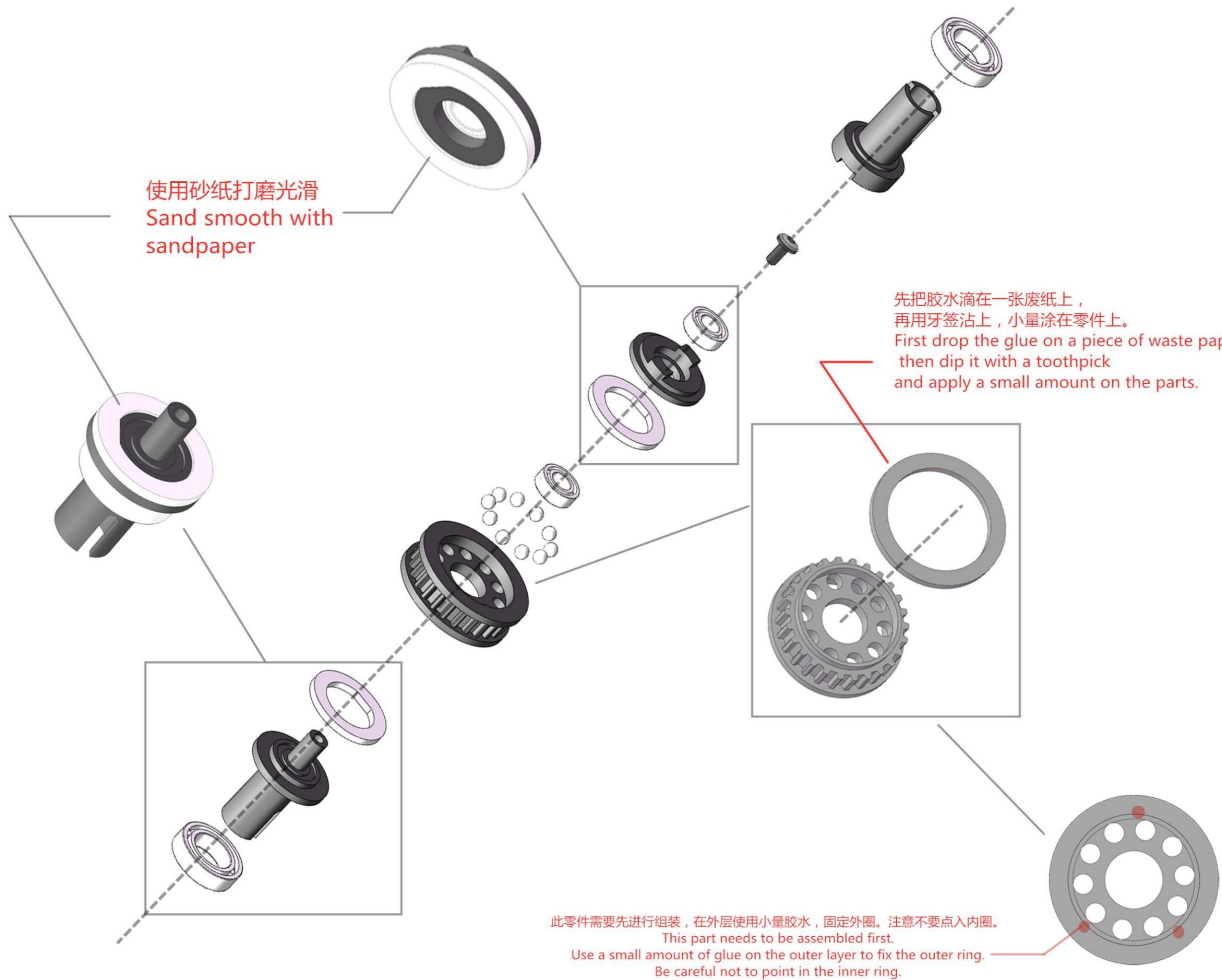

Differential mechanism

差速器

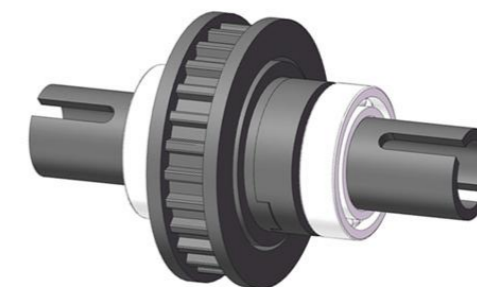
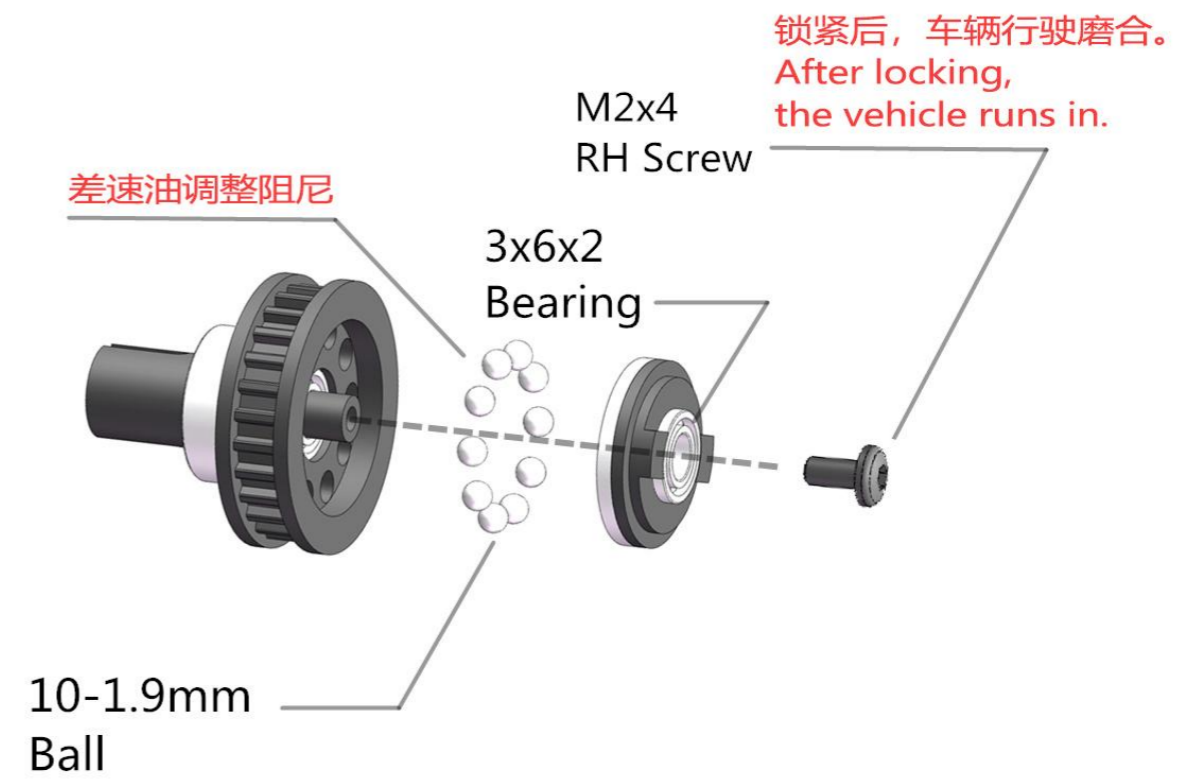
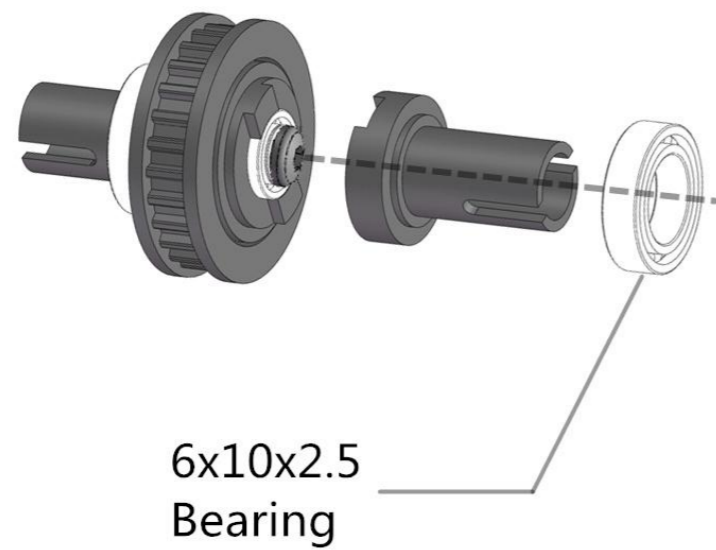
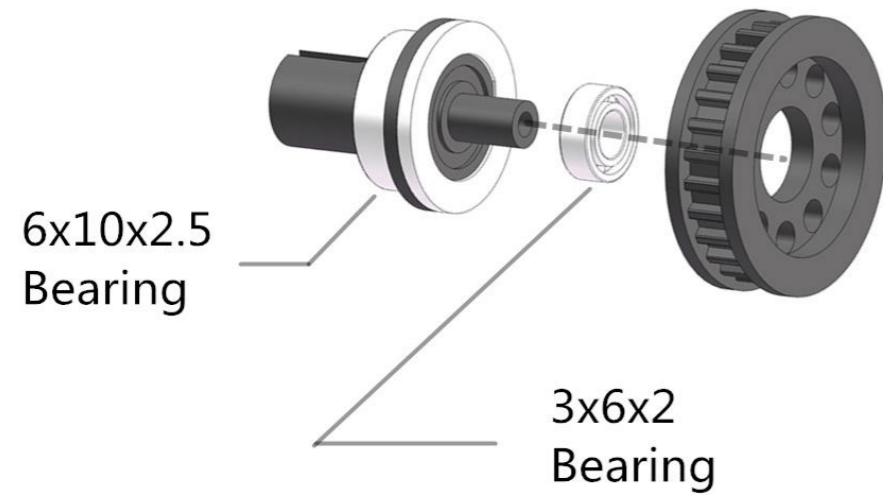

Description of differential damping effect

差速器阻尼效果说明

1. The damping effect is large, the rear of the vehicle is easy to adjust the angle, and the vehicle accelerates slowly.
 2. The damping effect is small, it is difficult to adjust the angle at the rear of the vehicle, and the vehicle accelerates quickly. (differential oil is not recommended)
- 1、阻尼效果大，车尾调整角度容易，车辆加速慢。
 - 2、阻尼效果小，车尾调整角度困难，车辆加速快。(推荐不使用差速油)

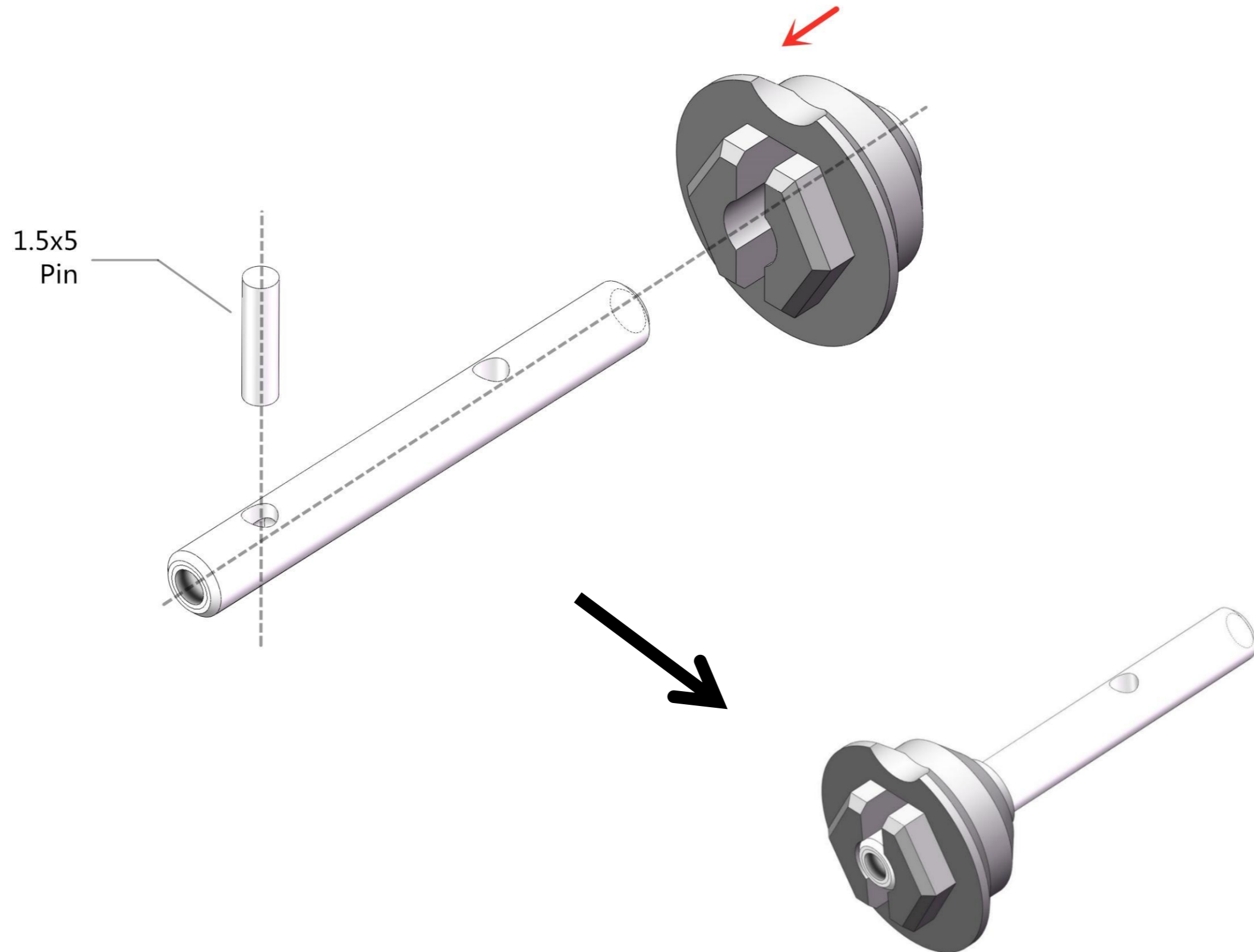

Belt drive installation method

皮带传动安装方式

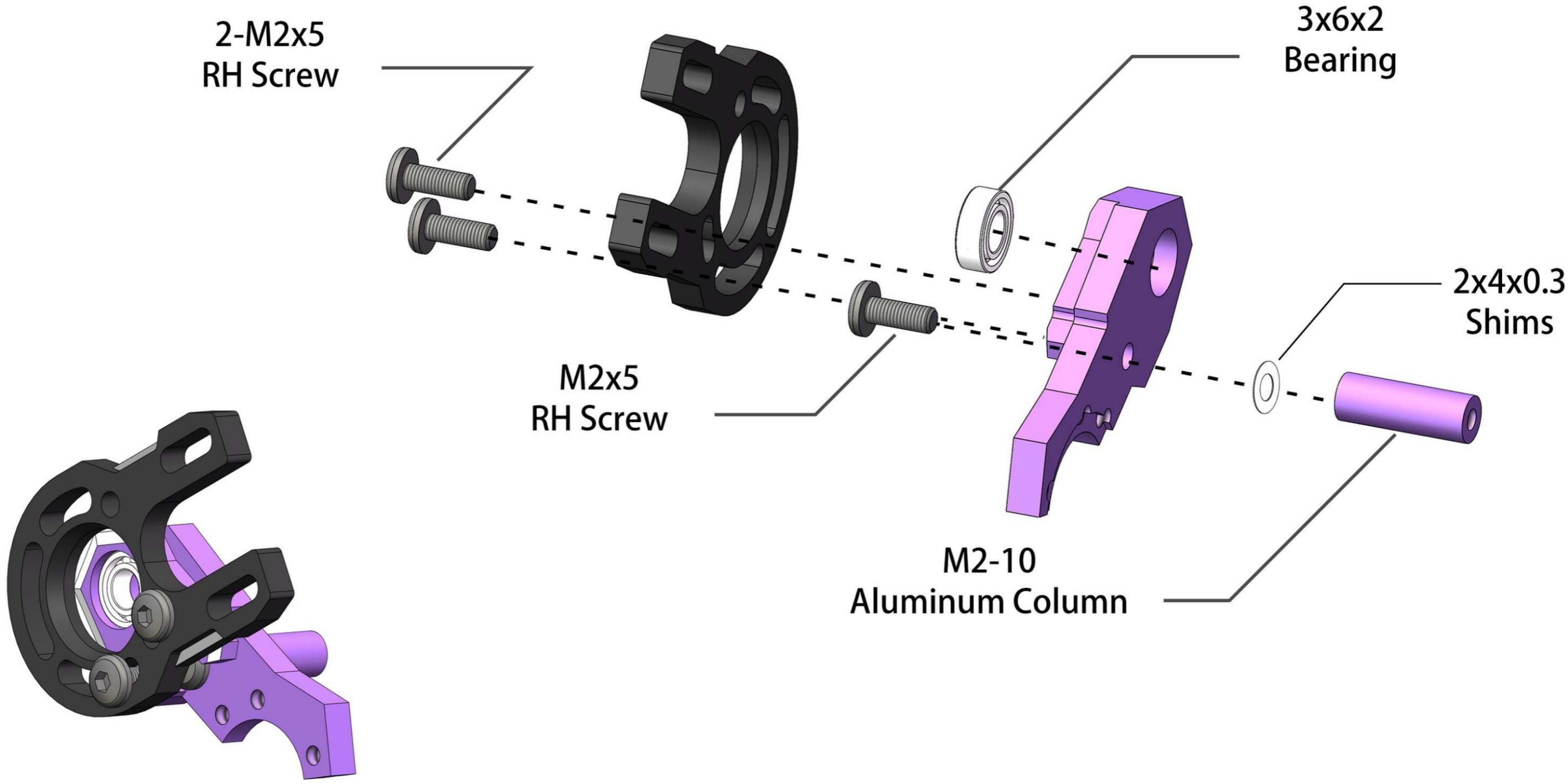

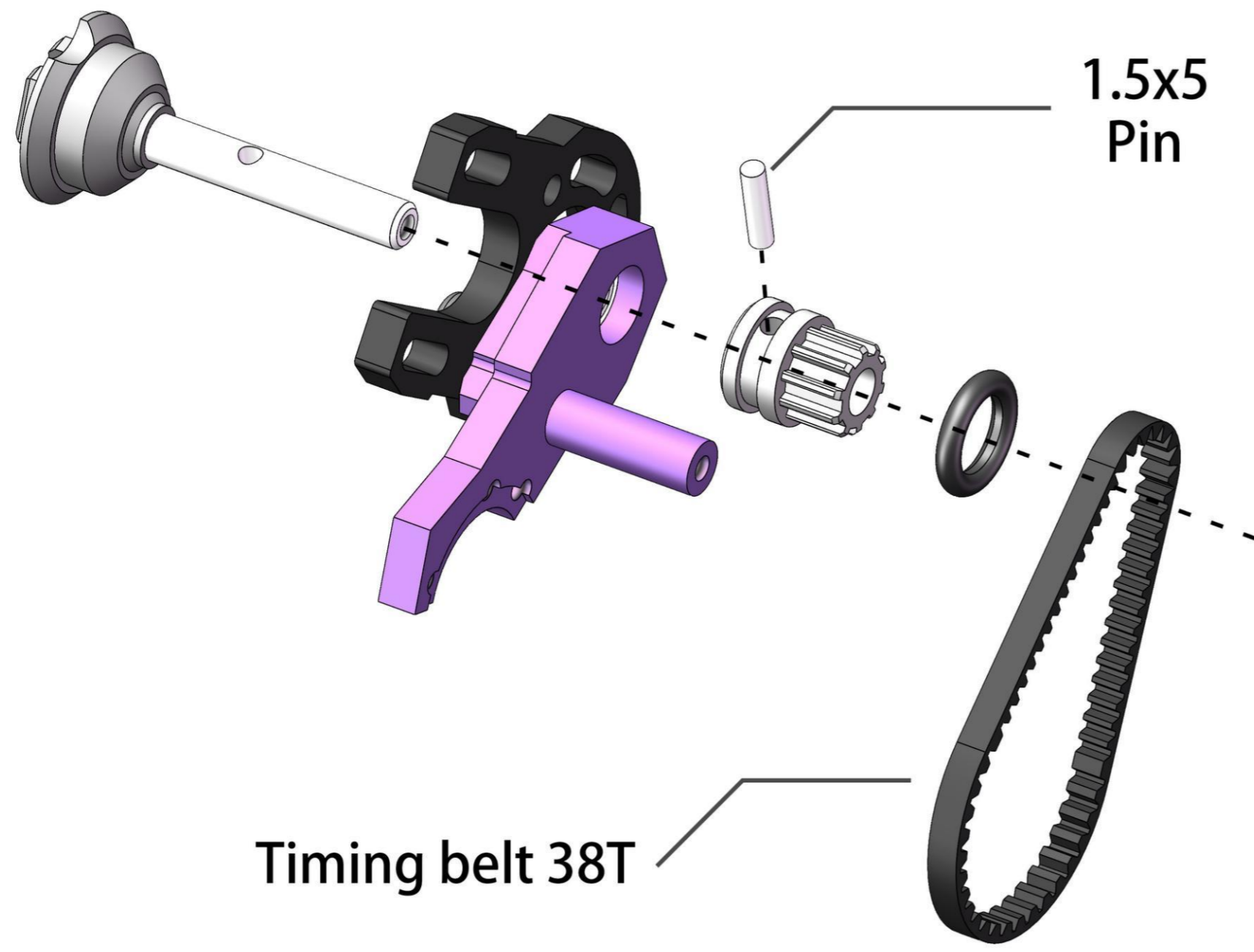

Belt drive installation method

皮带传动安装方式

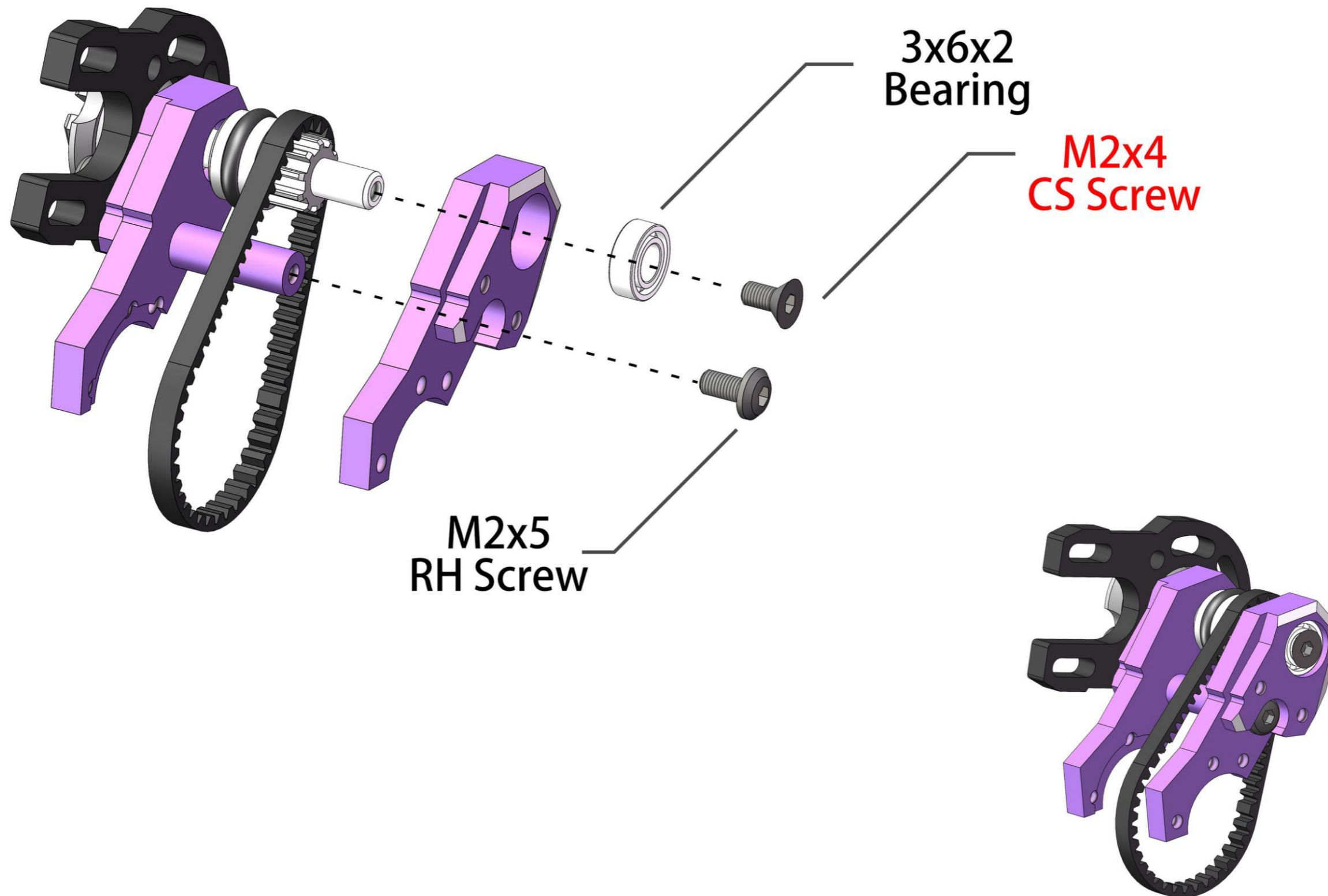

Gear transmission installation method

齿轮传动安装方式

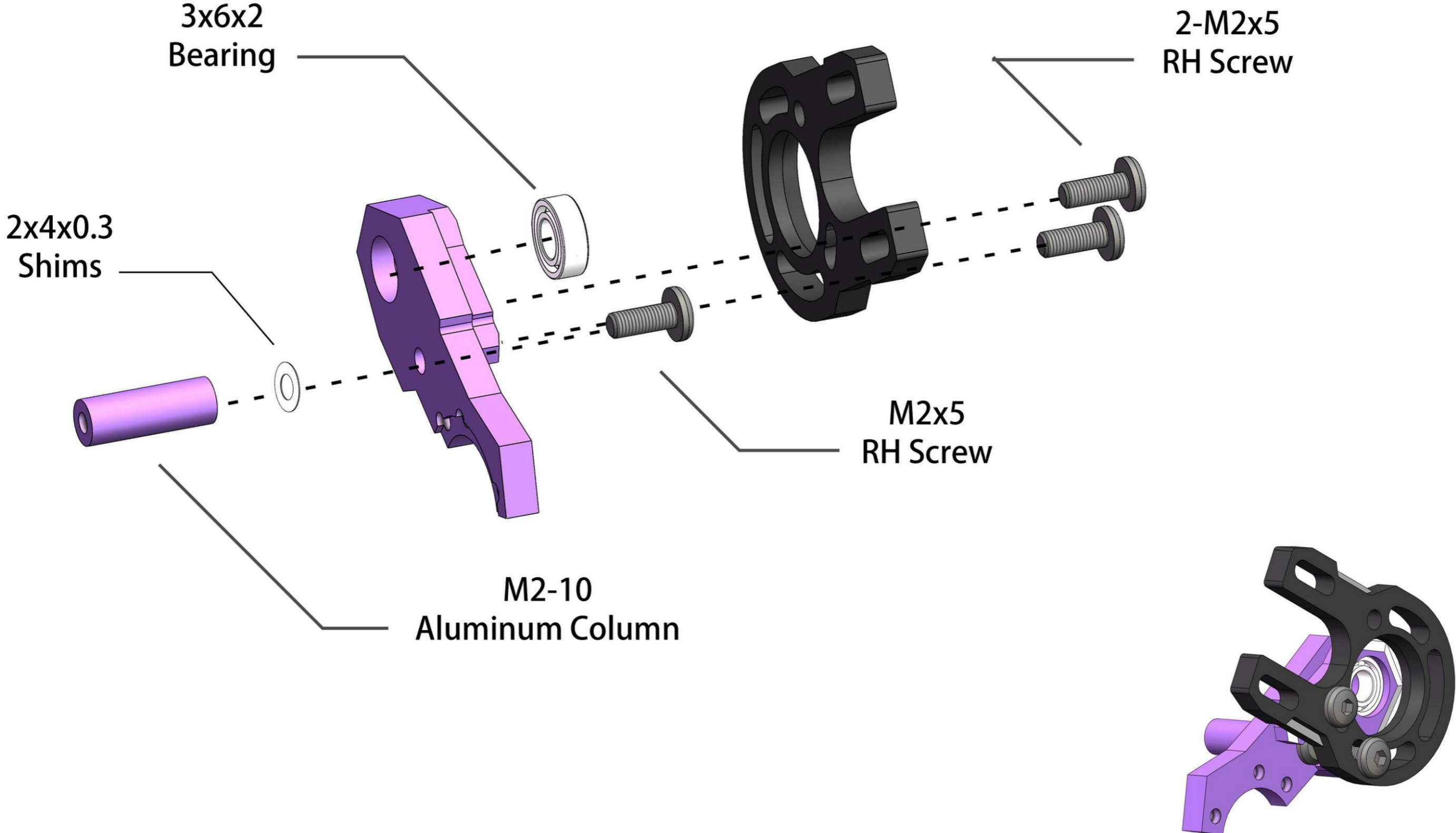

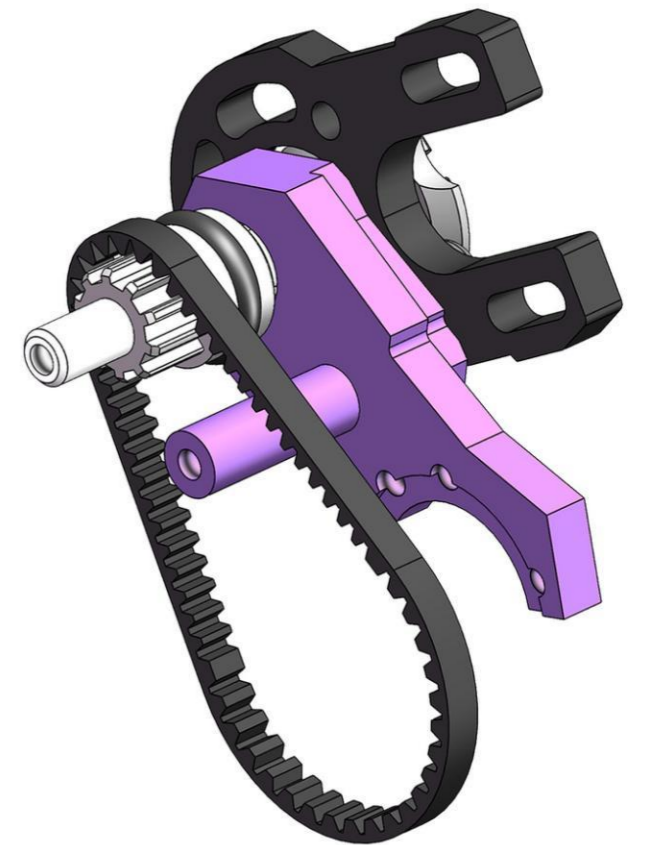
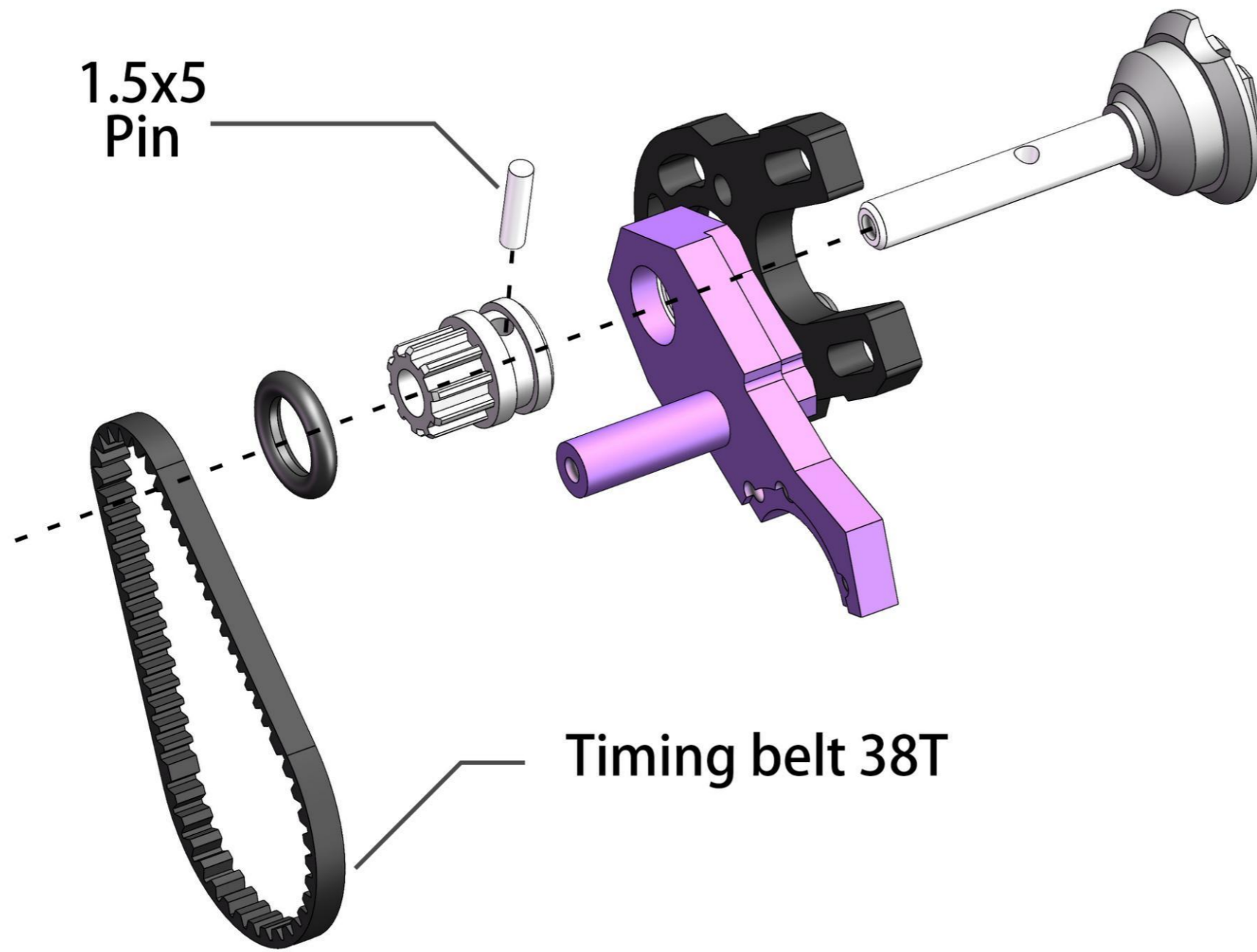

Gear transmission installation method

齿轮传动安装方式

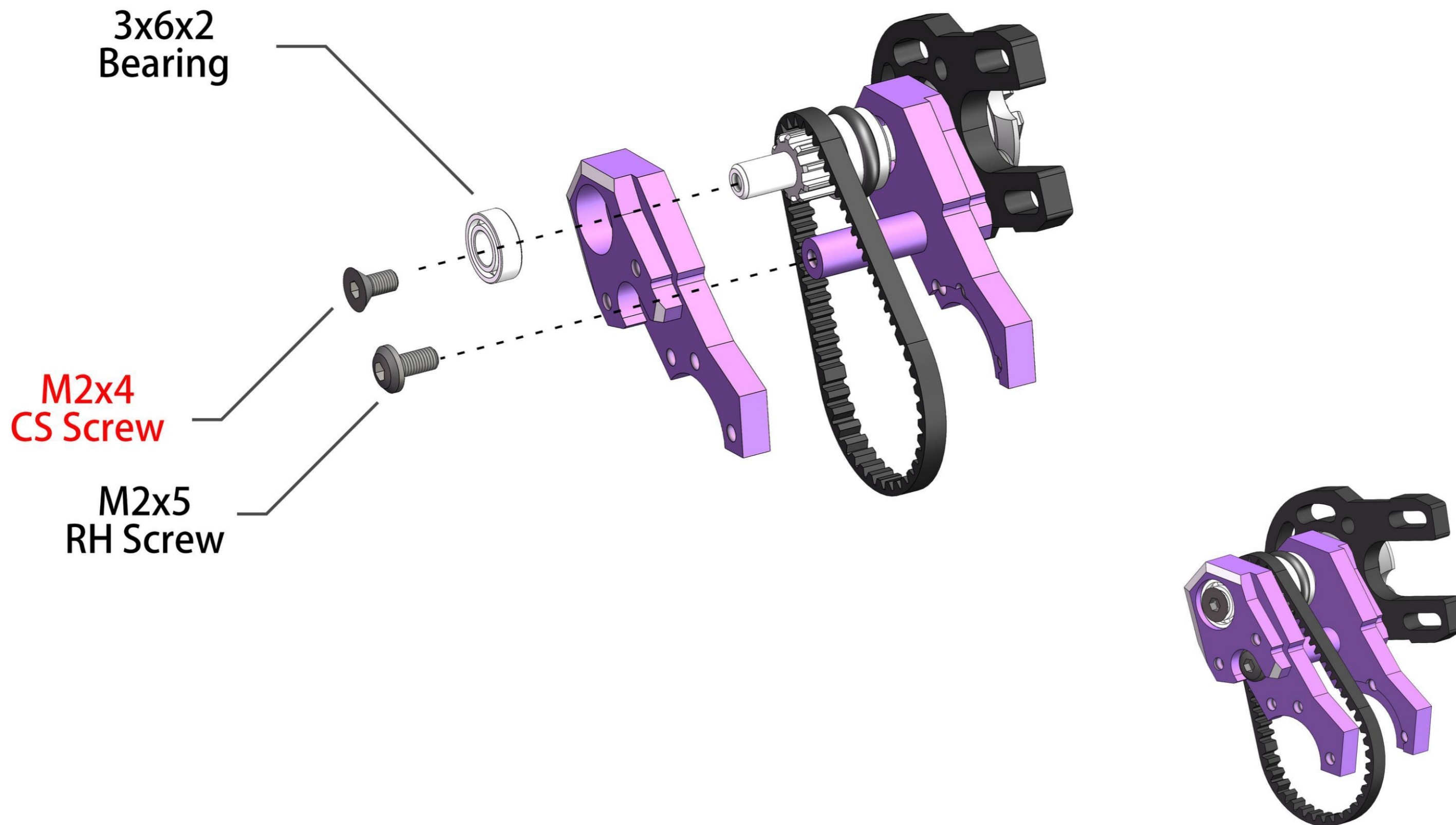

Belt drive installation method

皮带传动安装方式

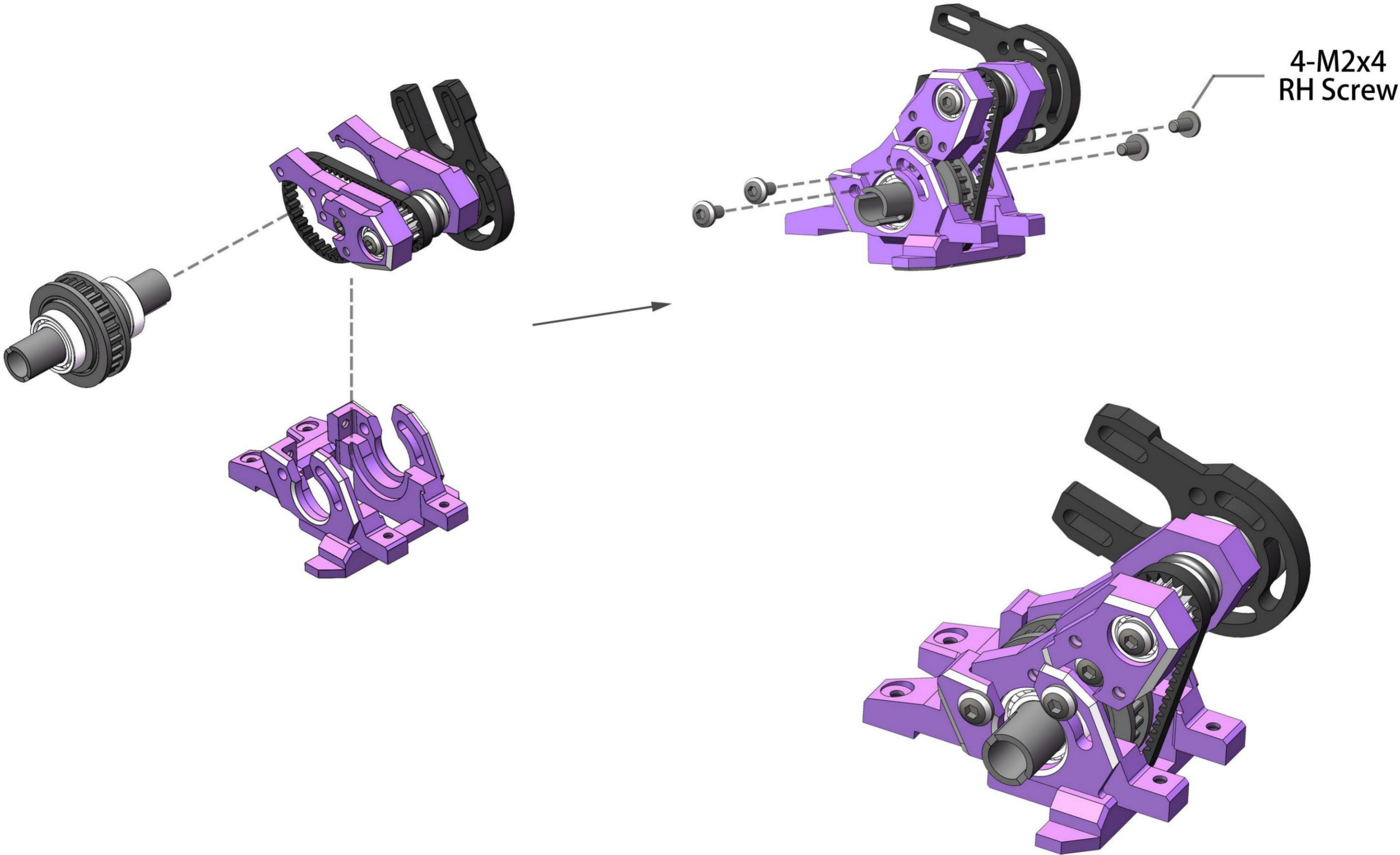

Gear transmission installation method

齿轮传动安装方式

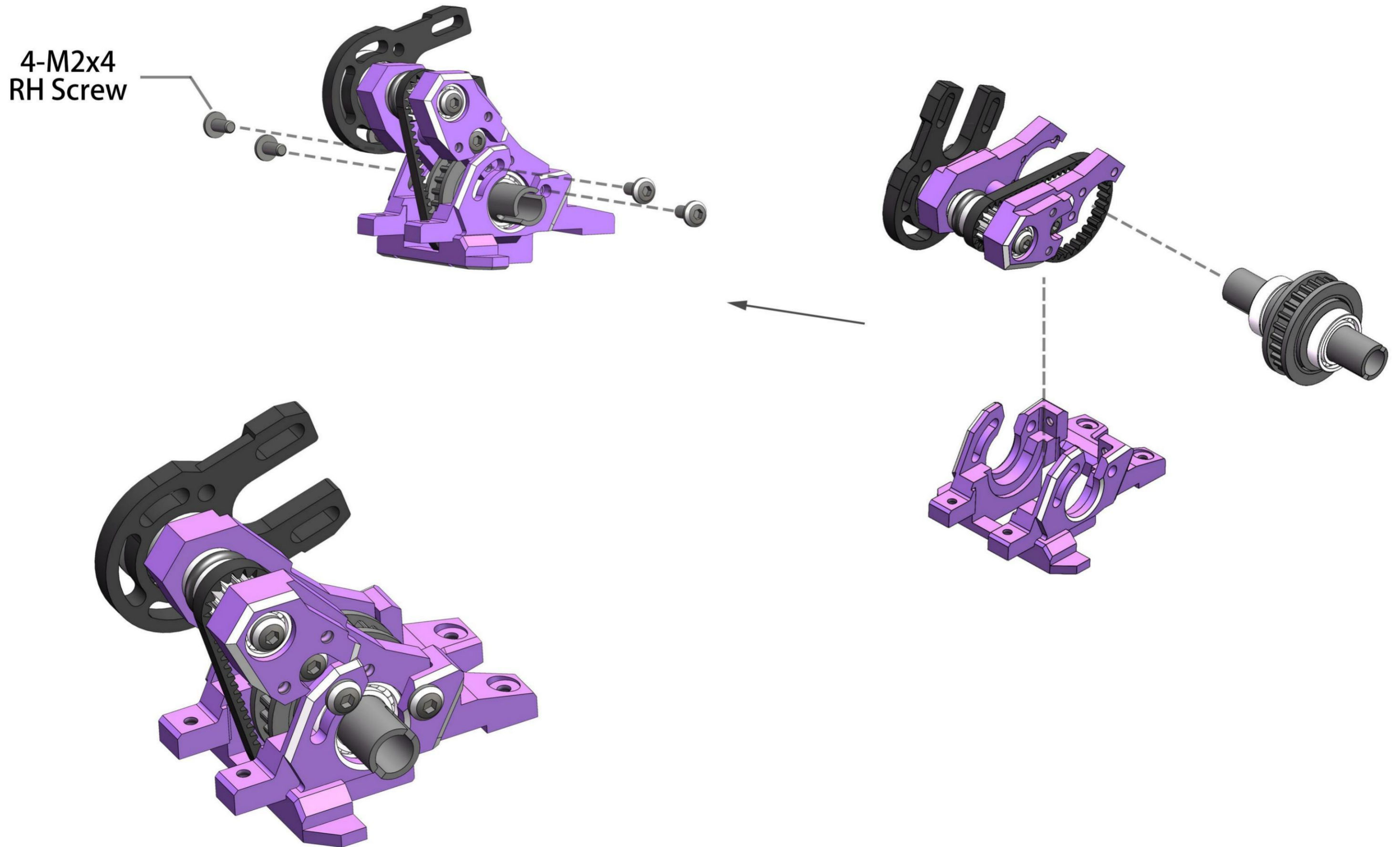

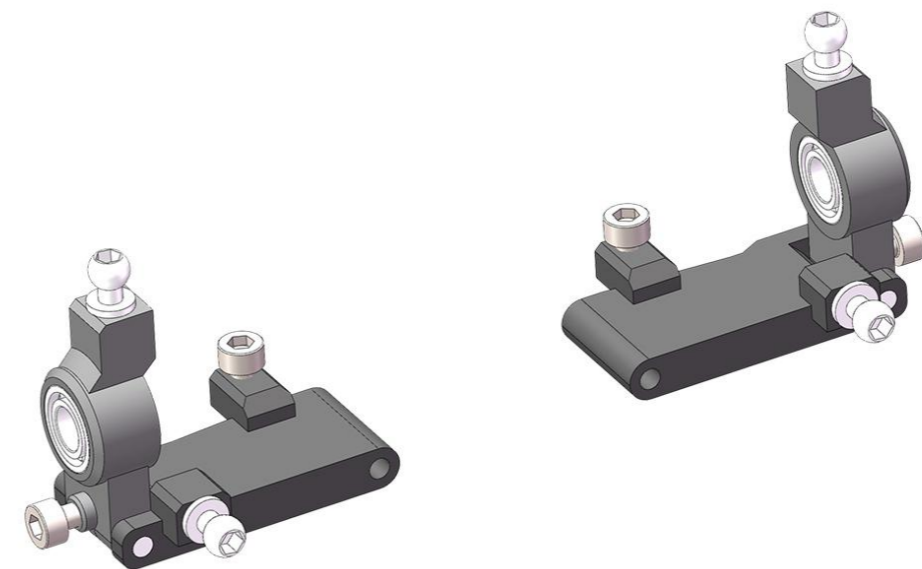
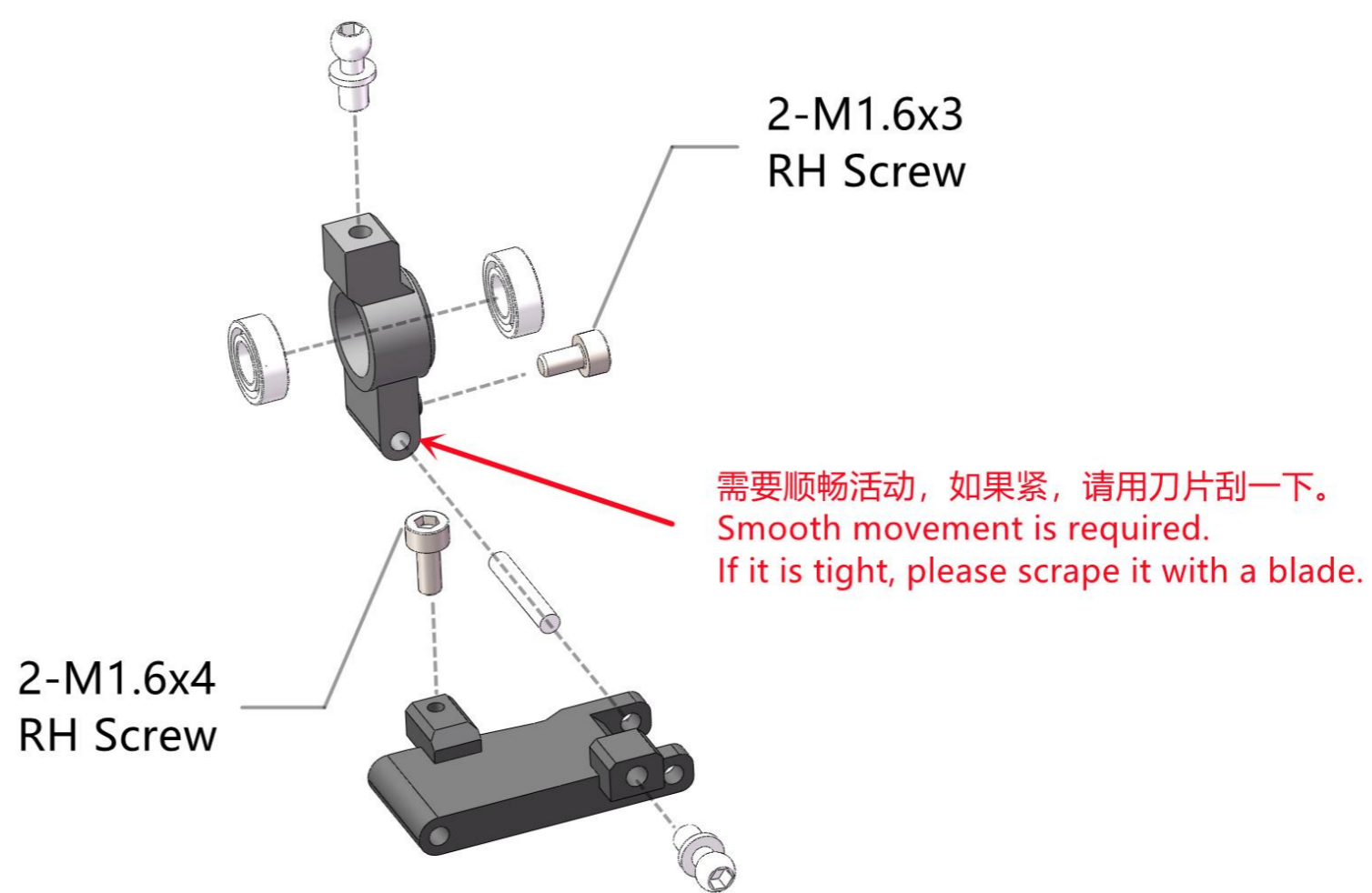
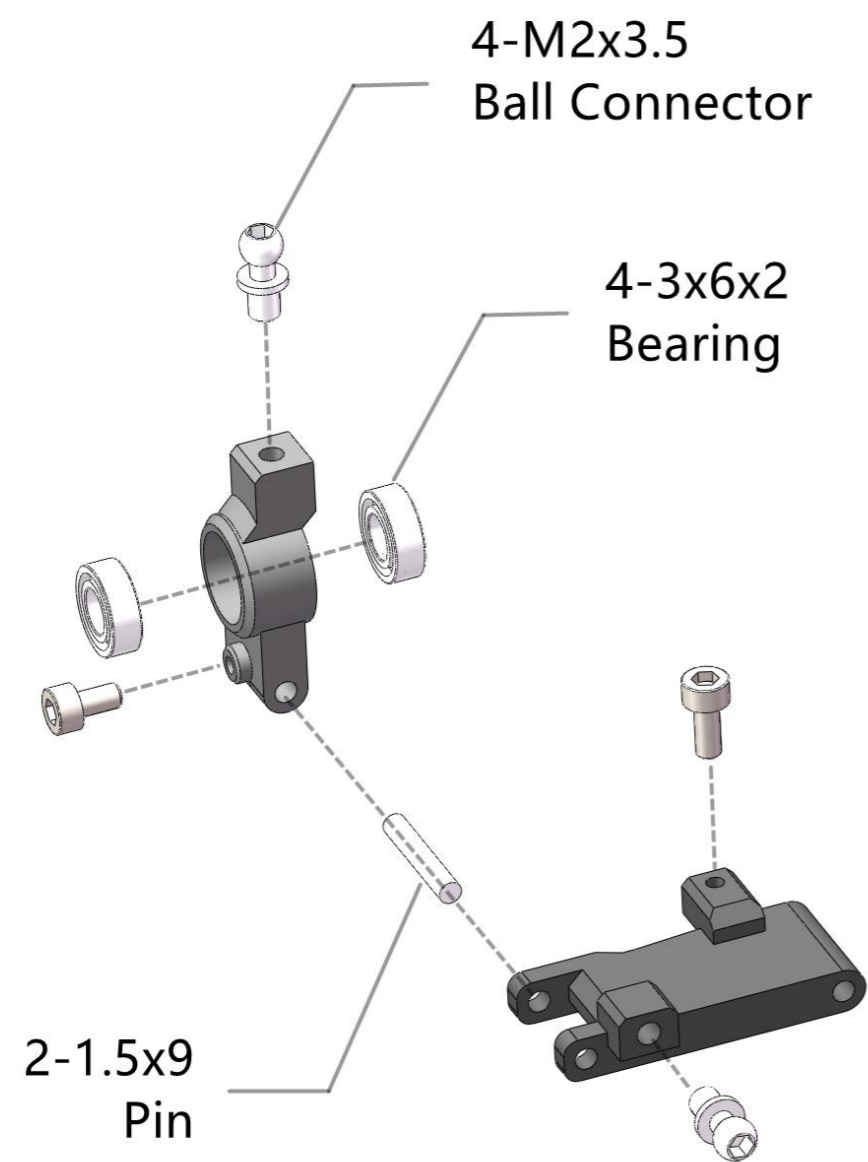

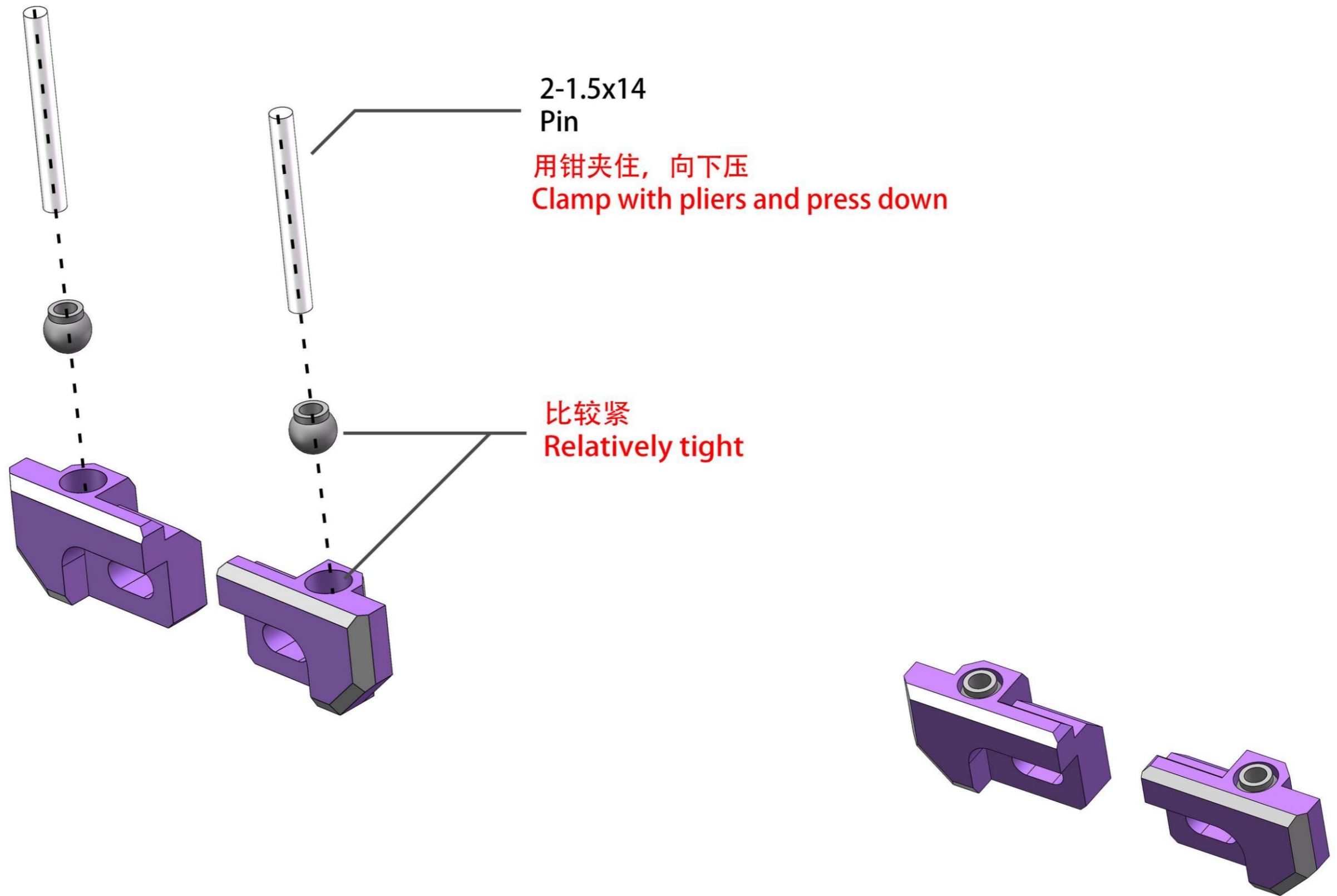

2-1.5x14
Pin

用钳夹住, 向下压
Clamp with pliers and press down

比较紧
Relatively tight

安装后, 再把 Pin 取出, 用于下一步安装。
After installation, take out the pin, For the next installation.

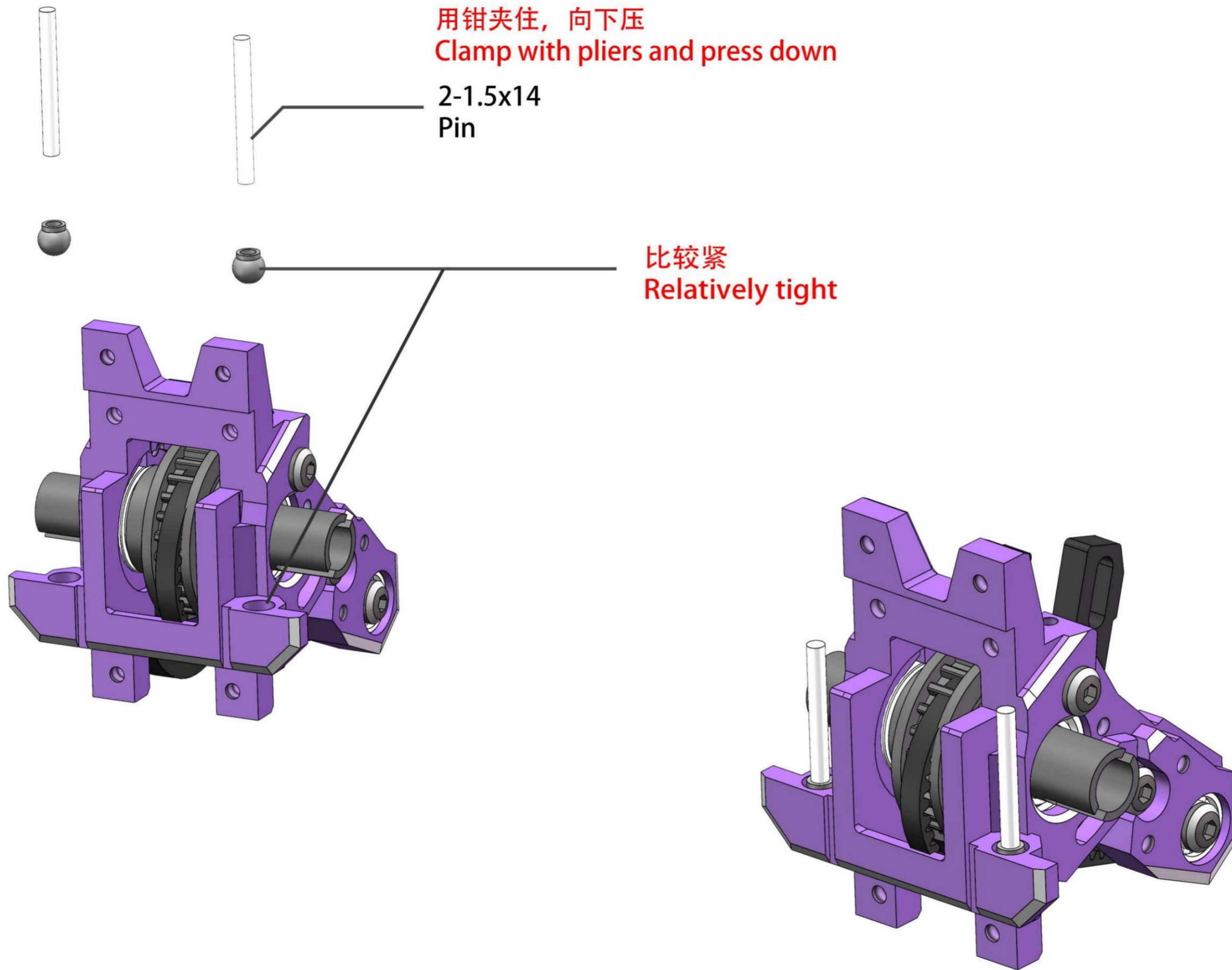

2-M2x5
RH Screw

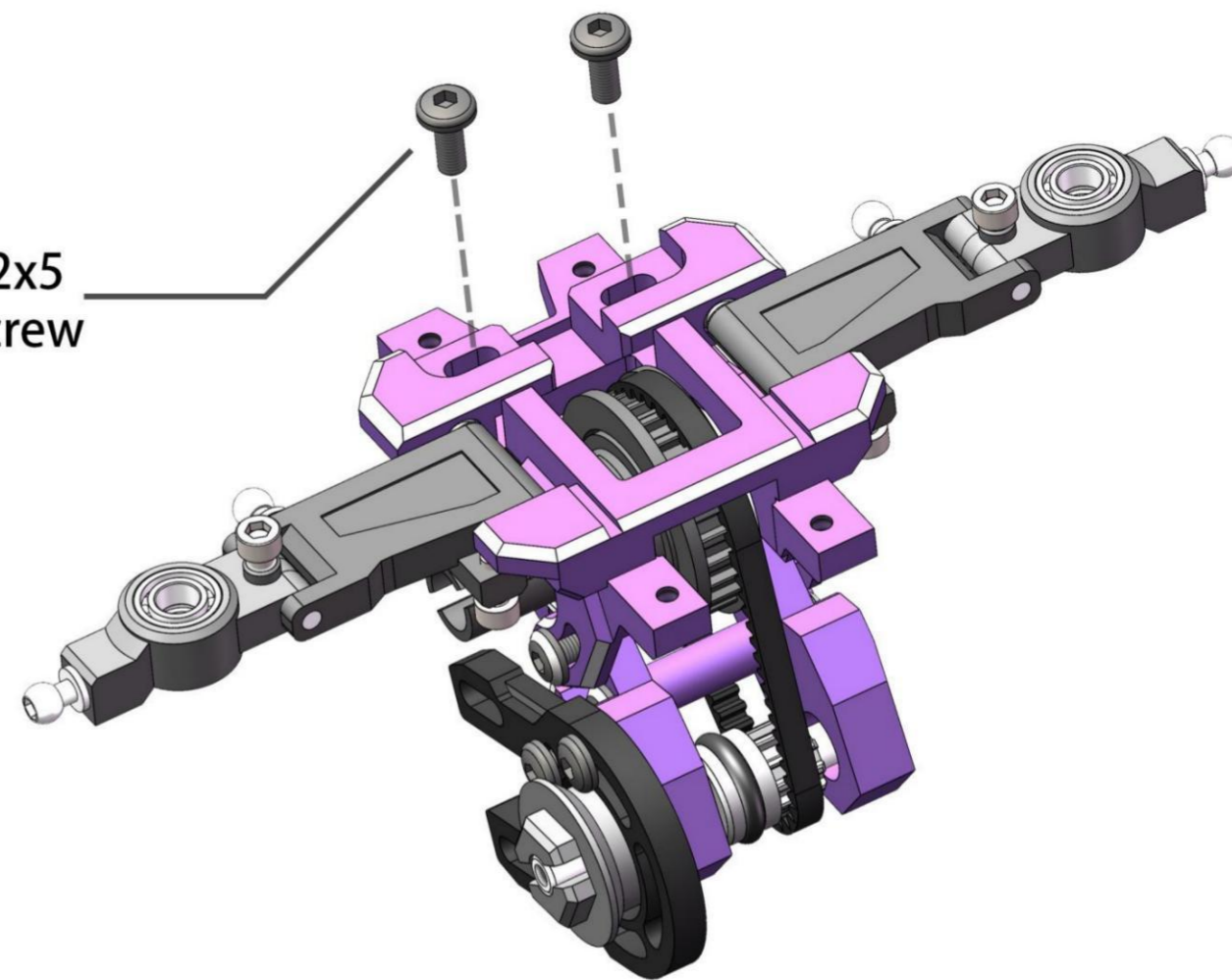

4-1.6x3x0.3
Shims

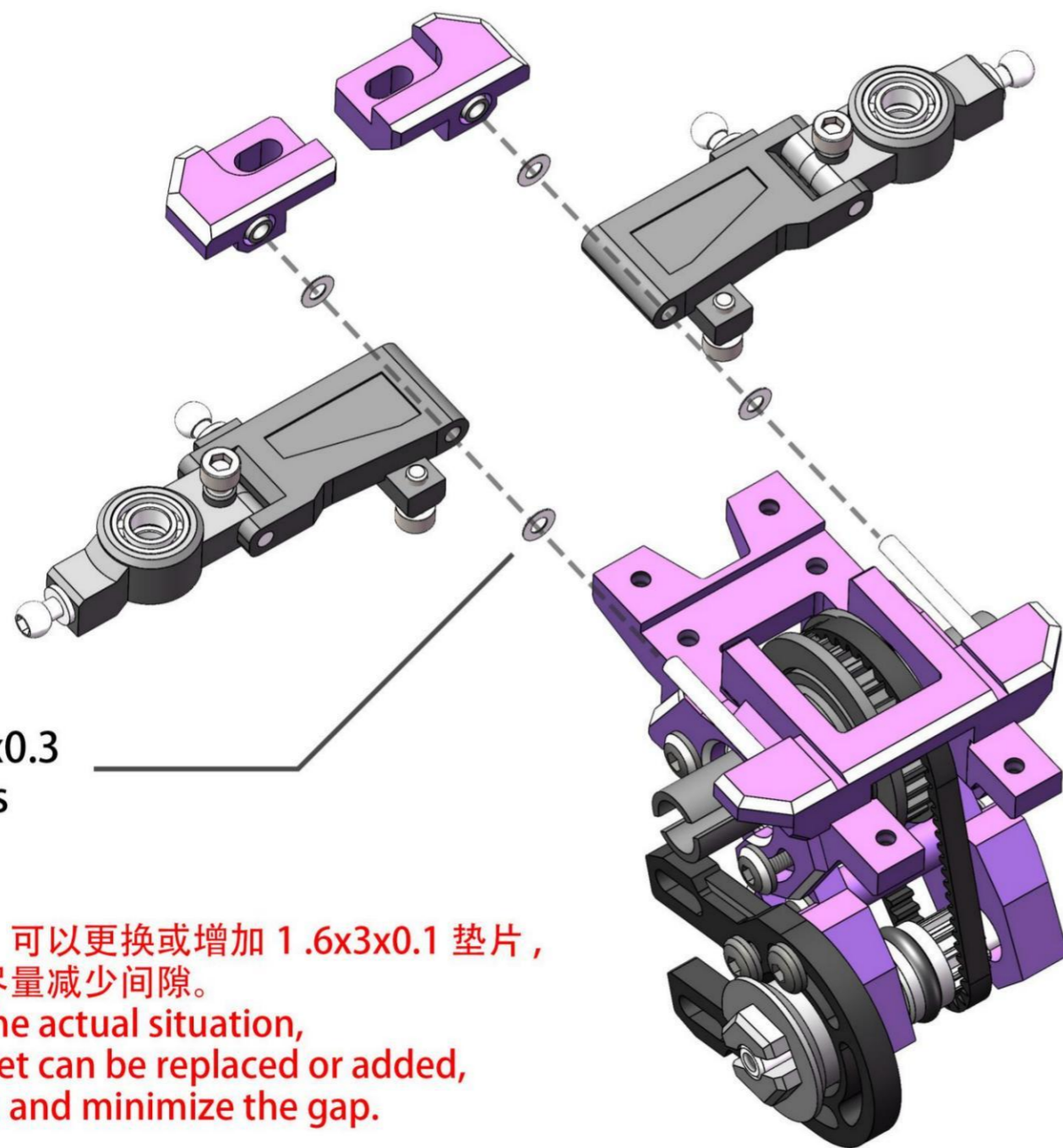

根据实际情况，可以更换或增加 1.6x3x0.1 垫片，
以顺畅为主，尽量减少间隙。
According to the actual situation,
1.6x3x0.1 gasket can be replaced or added,
Mainly smooth and minimize the gap.

上安装孔, 默认悬挂行程, 动作快。 (推荐)
Upper installation hole, default suspension travel, fast action.

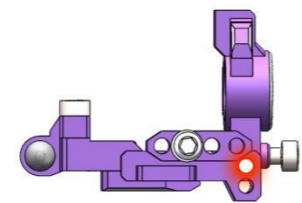

下安装孔, 增加悬挂行程, 动作线性。
Lower installation hole, increase suspension travel and linear action. (Recommended)

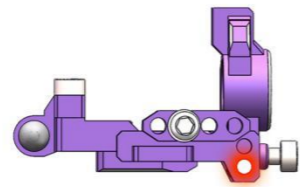

此安装孔, 需更换配件包内的1.4x10 Pin。
This installation hole requires replacement of the 1.4x10 pin in the accessory package.

(推荐)
(Recommended)

增加悬挂线性
Increase suspension linearity

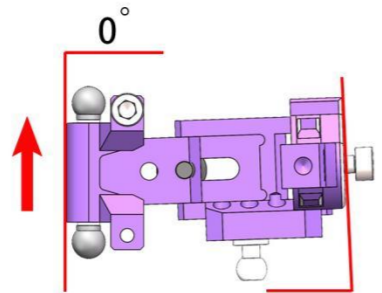
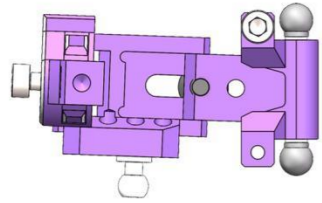

Teo in 2°

增快悬挂恢复
Accelerated suspension restoration

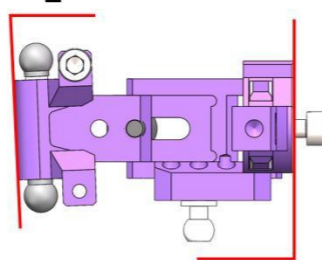
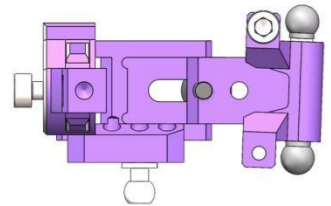

Teo 0°

4-1x3x1
Bearing



(X)

孔径偏小
Small aperture



(✓)

孔径偏大
Big aperture

此轴承正反面的孔径不一样,
请用偏大的那边进入。

The holes on the front and back
of this bearing are different.
Please use the larger side to enter.

4-1x2x0.3
Shims

根据实际情况, 可以更换或增加 1x2x0.1 垫片,
以顺畅为主, 尽量减少间隙。

According to the actual situation,
1x2x0.1 gasket can be replaced or added,
Mainly smooth and minimize the gap.

Bearing - Rear Lower Arm

轴承 - 后下摆臂

Optional parts

选装升级配件

2-1.4x10
pin

4-1x1.5x1.8
Guide sleeve

2-M1.6x4
RH Screw

2-1x14
pin

2-M2x4
RH Screw

2-M1.6x3
RH Screw

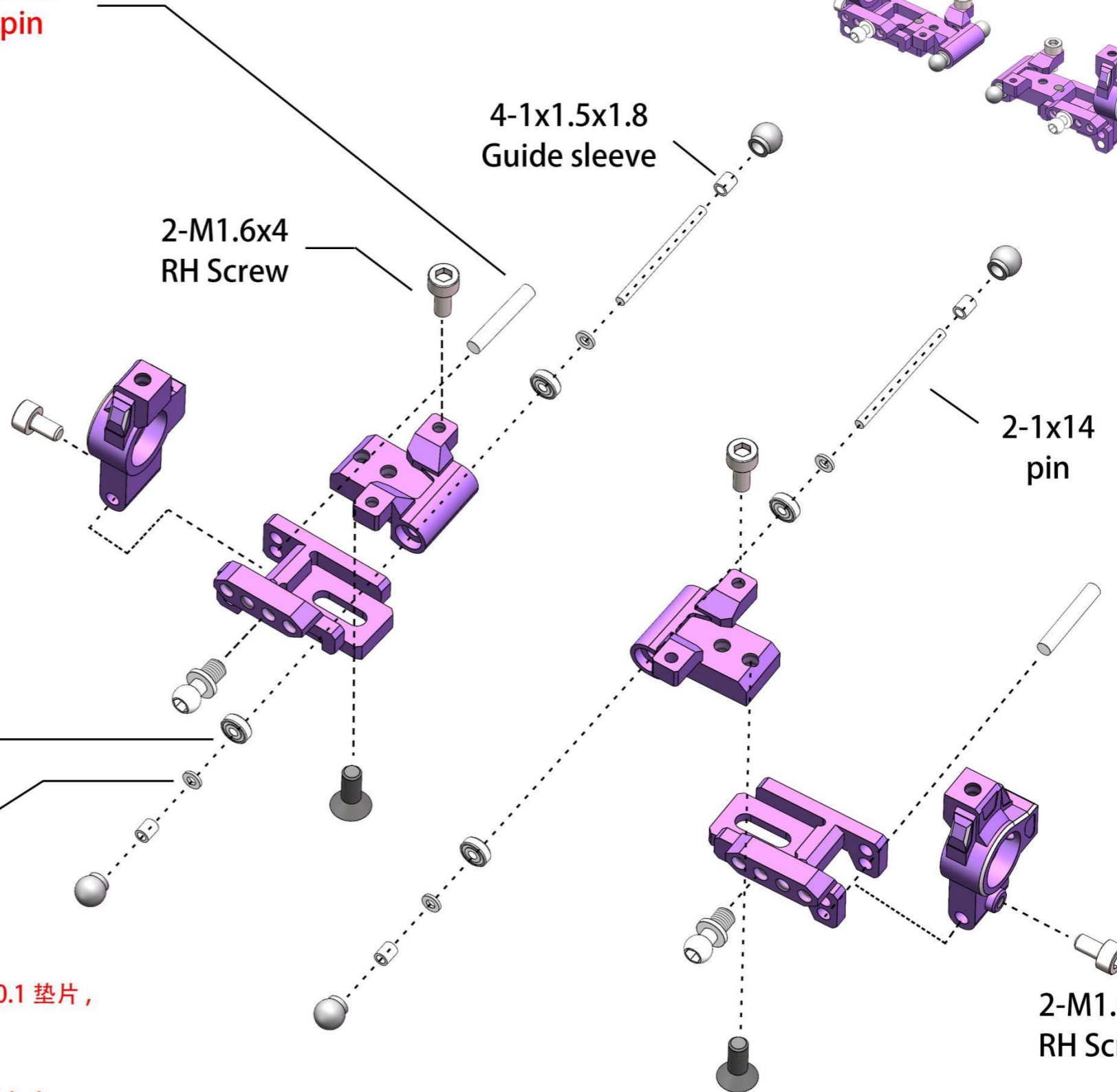
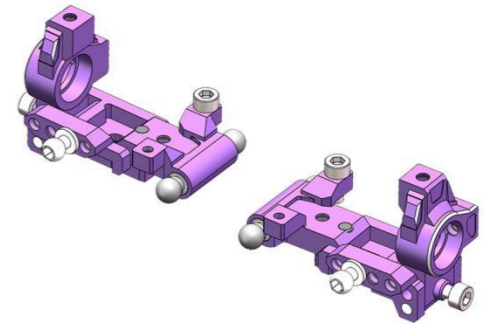

Belt drive installation method

皮带传动安装方式

皮带模式特点:

- 1、车辆反应慢。
- 2、行驶加速容易。
- 3、噪音偏少。

Belt mode features:

1. The car reacted slowly.
2. Easy acceleration.
3. Less noise.

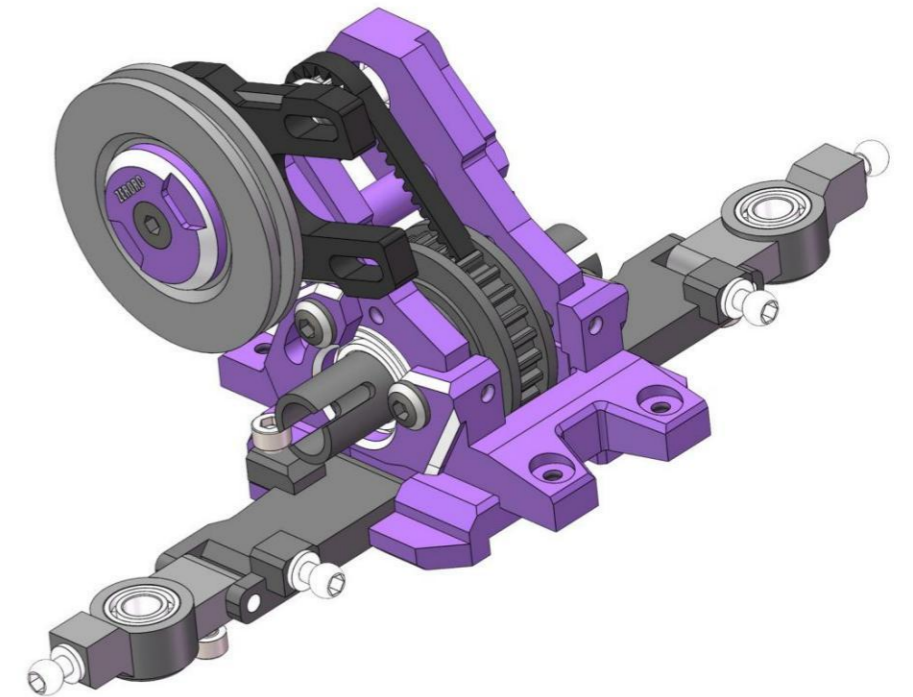
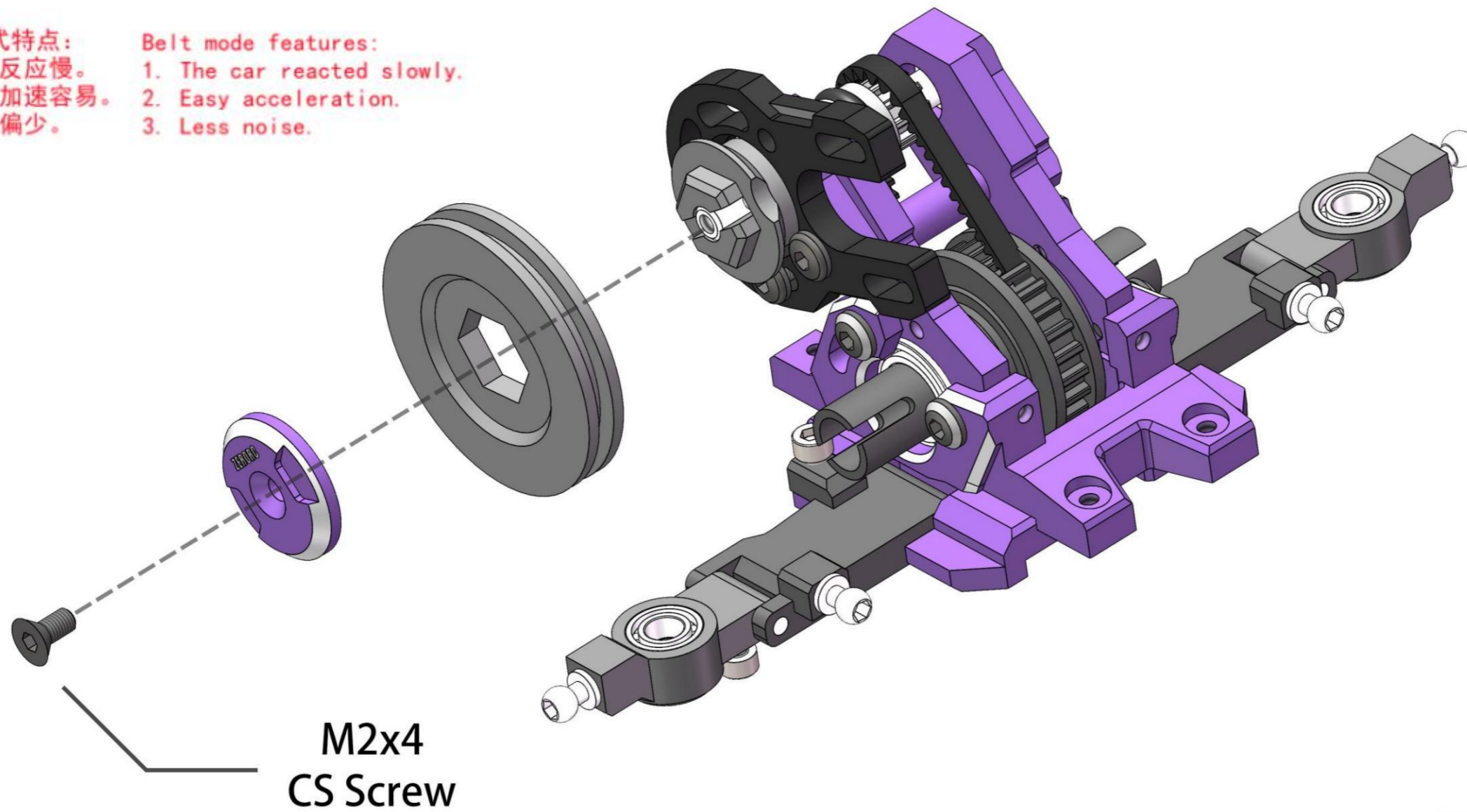

Gear transmission installation method

齿轮传动安装方式

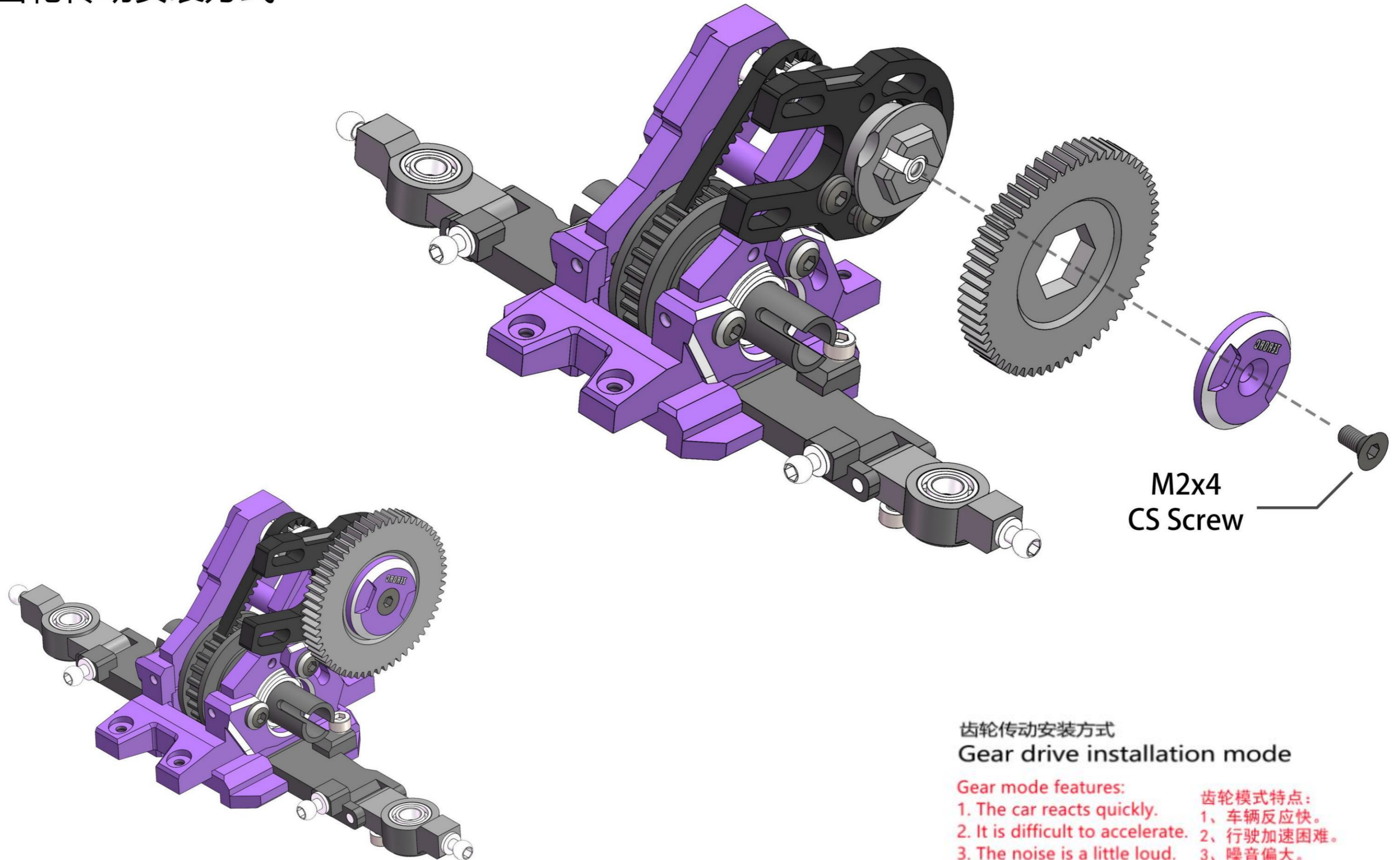

齿轮传动安装方式

Gear drive installation mode

Gear mode features:

1. The car reacts quickly.
2. It is difficult to accelerate.
3. The noise is a little loud.

齿轮模式特点:

- 1、车辆反应快。
- 2、行驶加速困难。
- 3、噪音偏大。

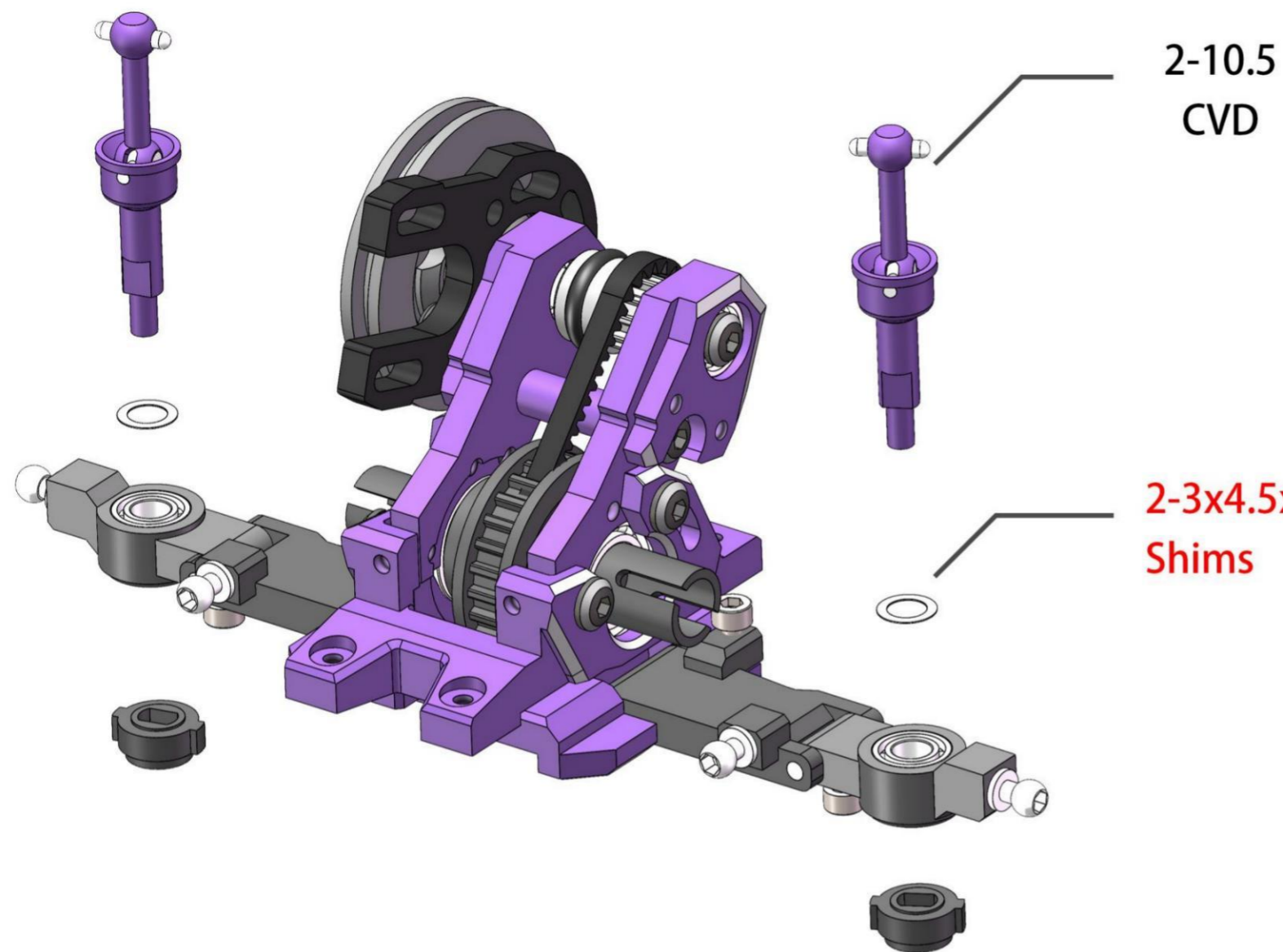

根据实际情况选择安装垫片的数量；
优先考虑平滑度，并尽可能减少间隙。
Select the number of installation
gaskets according to the actual situation;
Prioritize smoothness and minimize gaps as much as possible.

下面安装将主要以皮带传动为示范，
齿轮传动的安装步骤也将相同
The following installation will mainly focus on
belt transmission as a demonstration,
and the installation steps for gear transmission will also be the same

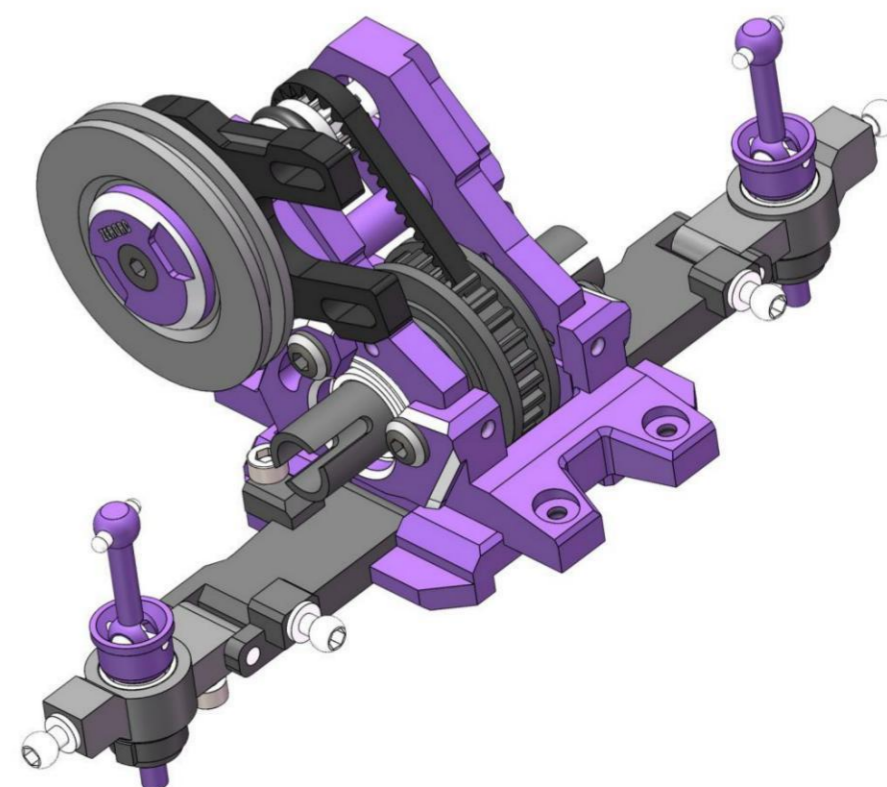

4-M2x3.5
Ball Connector

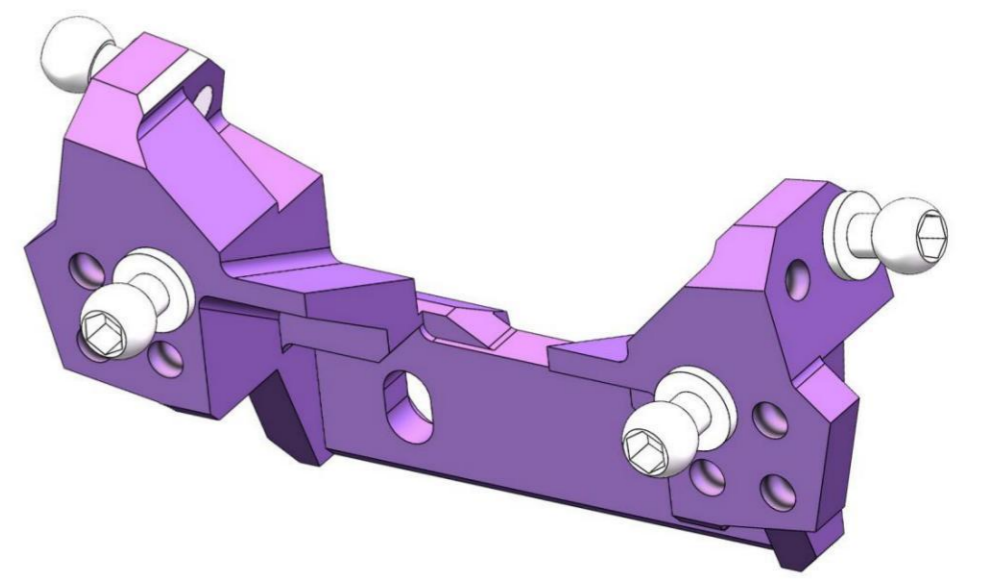
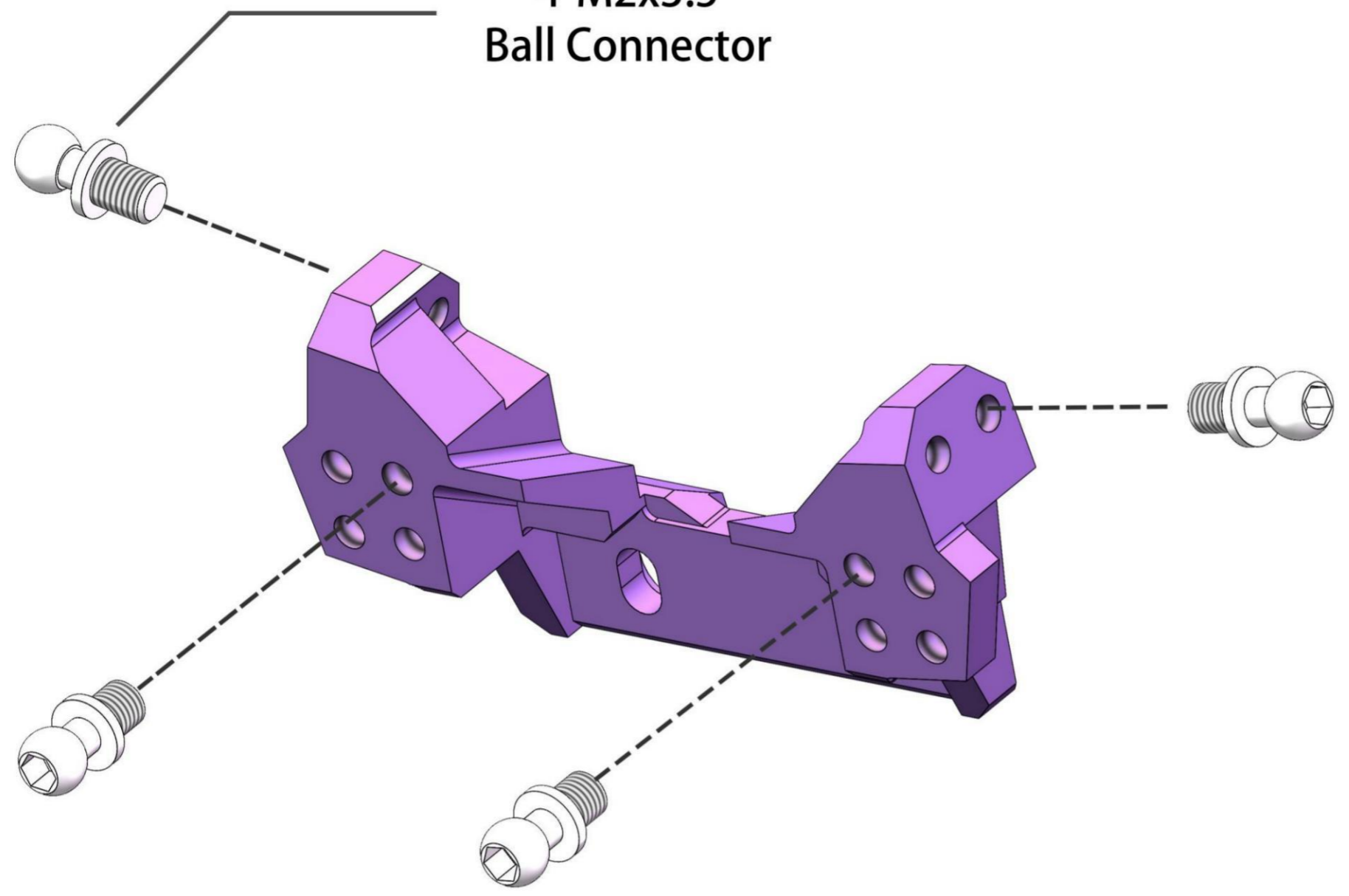

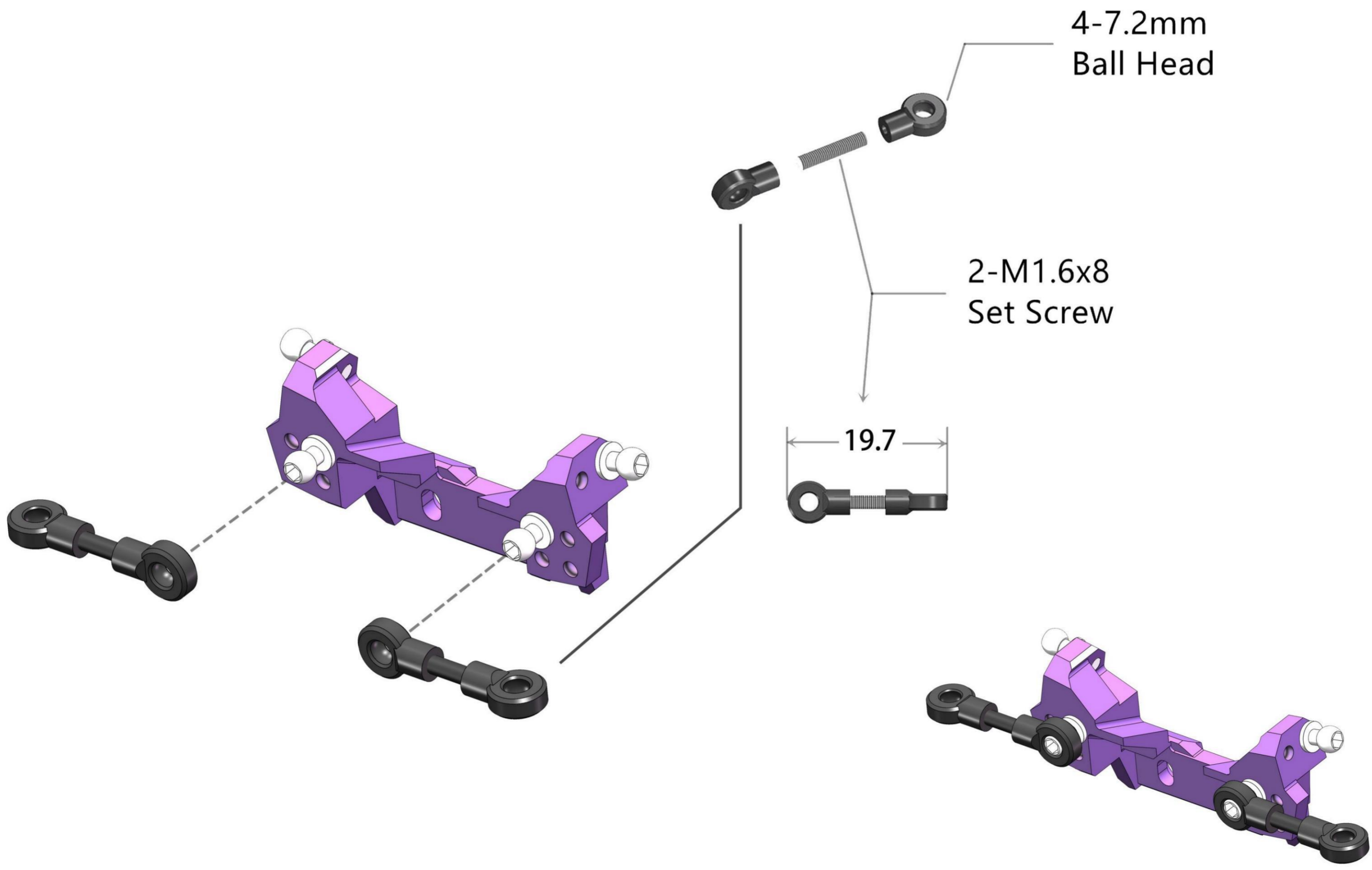

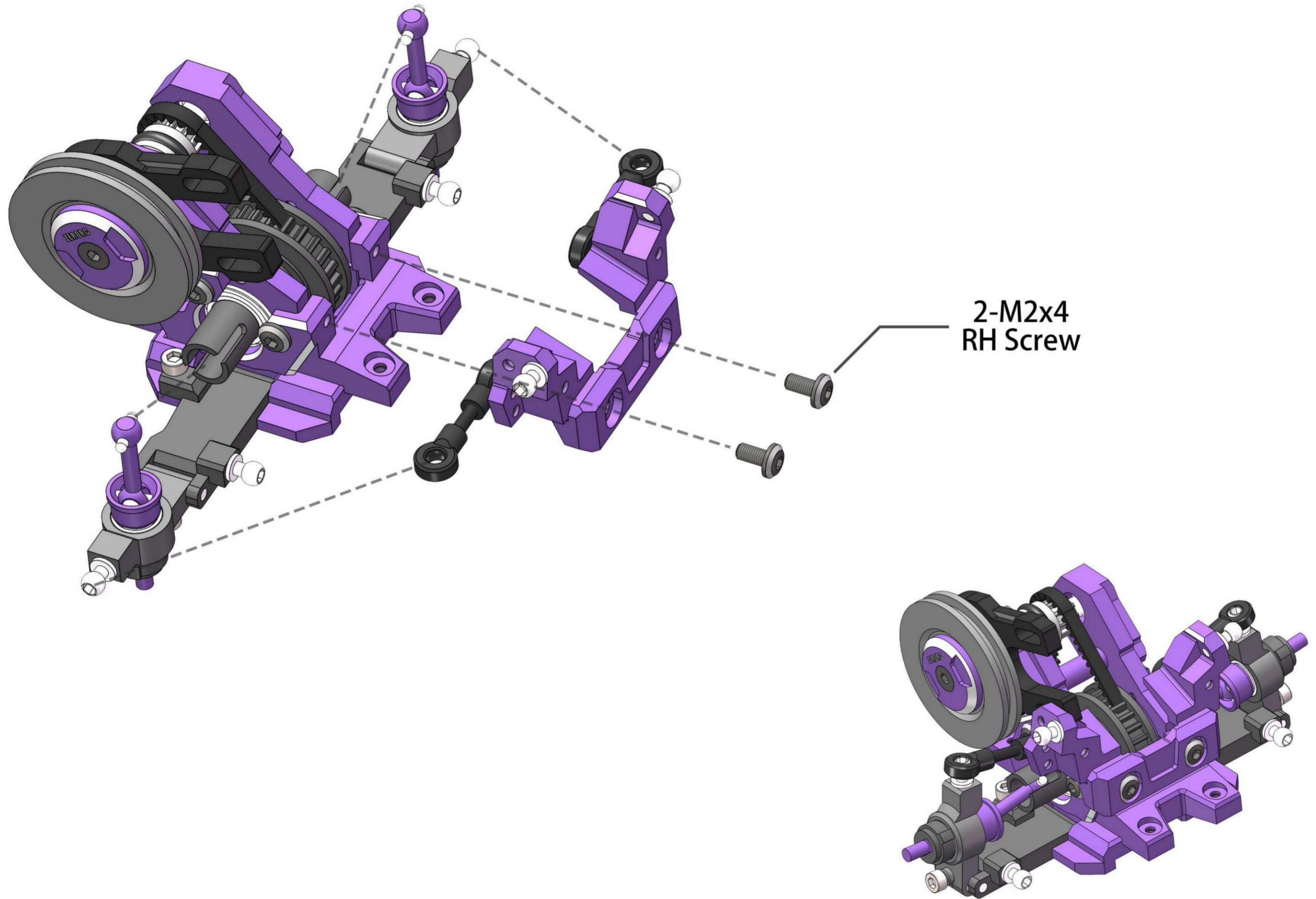

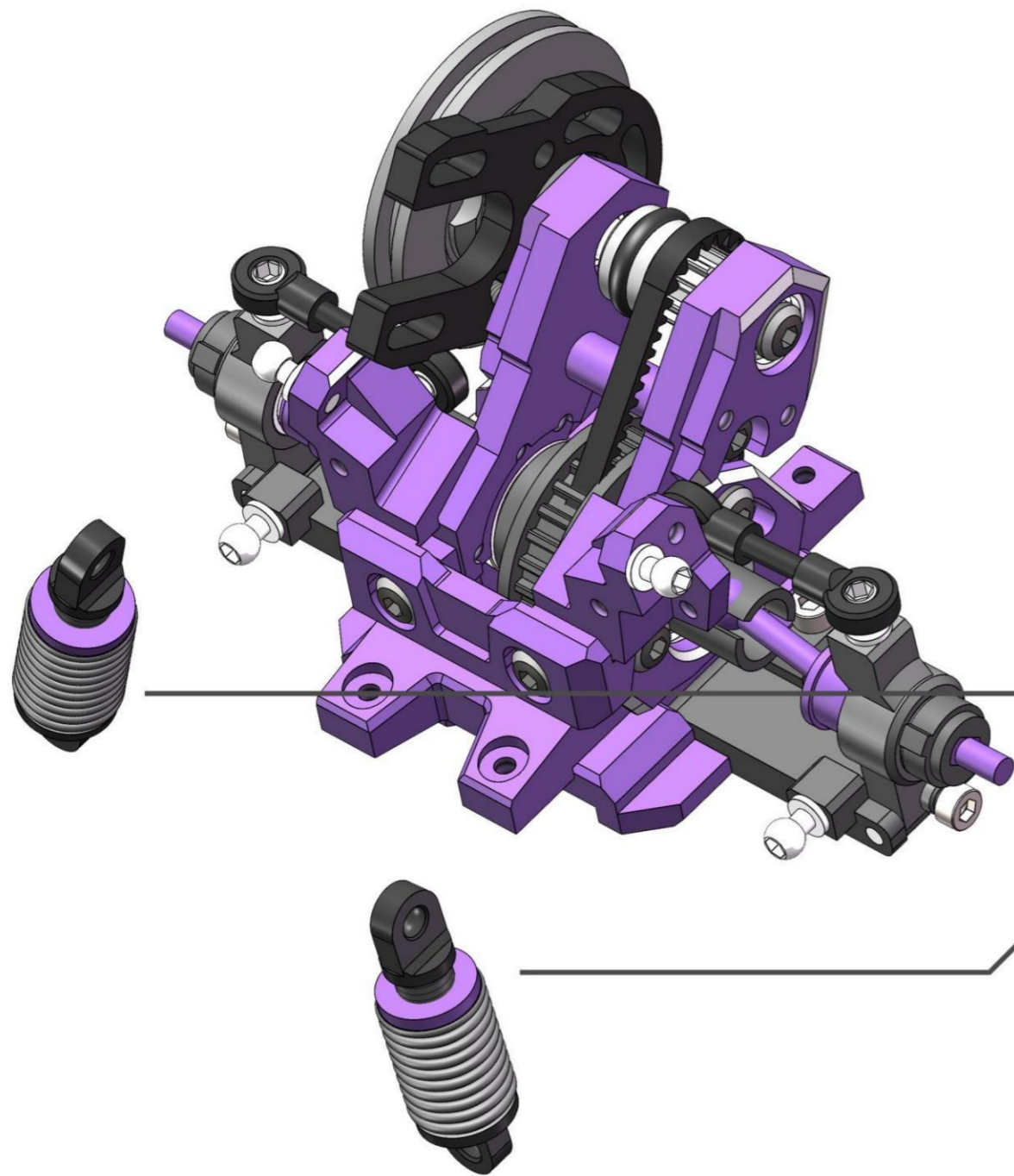

长
Long

软
Soft

长
Long



Handle the clamping line of the shock absorber rod to be smooth.
处理避震杆的合模线至光滑

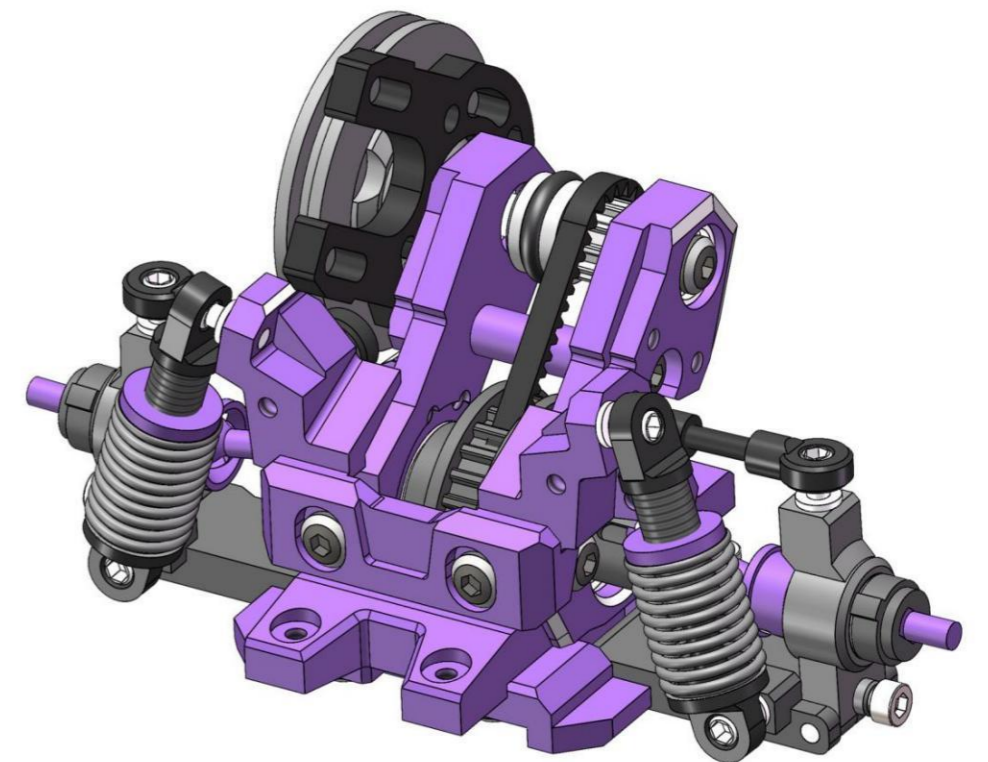

Belt drive installation method

皮带传动安装方式

2- M2x5
RH Screw

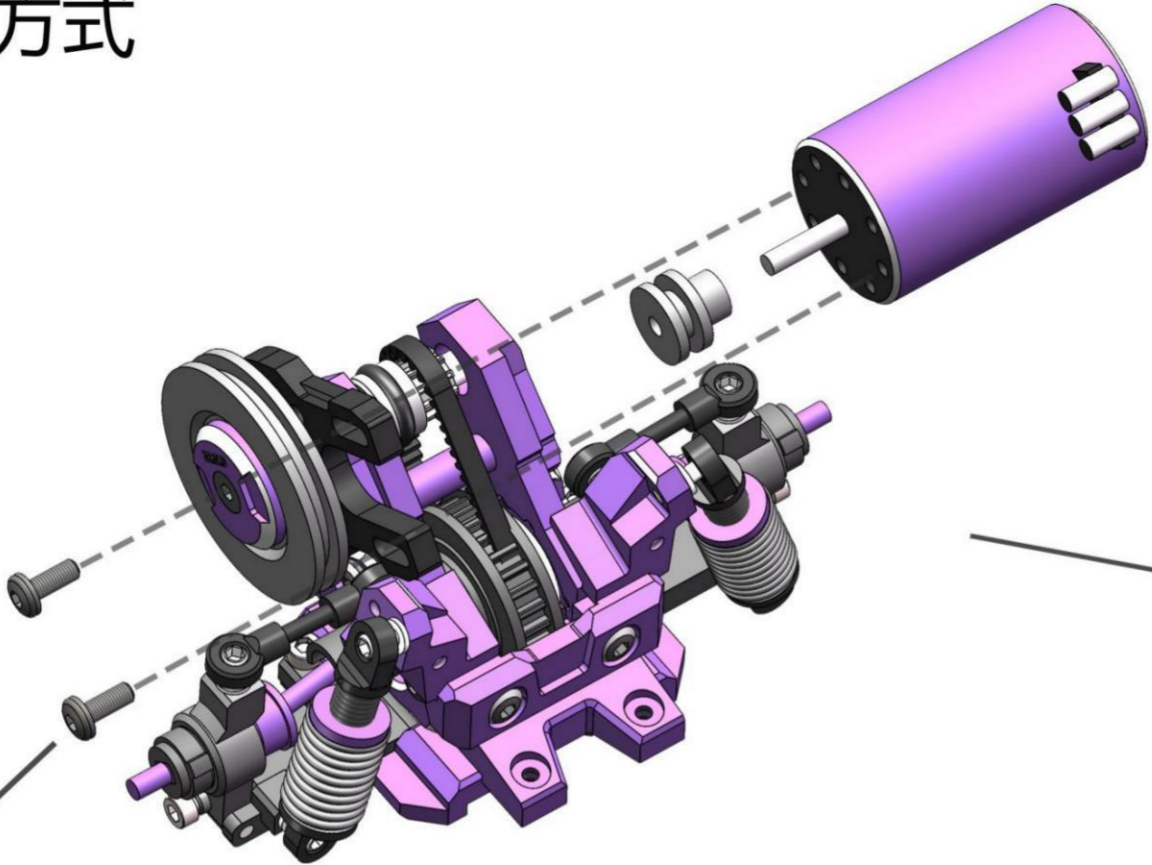

皮带轮坑槽对齐
Belt pulley groove alignment

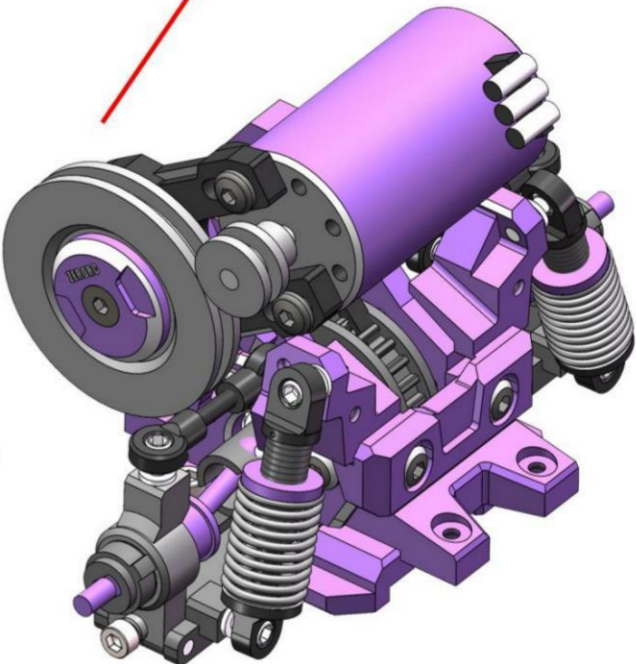

皮带不能太紧
The belt cannot be too tight

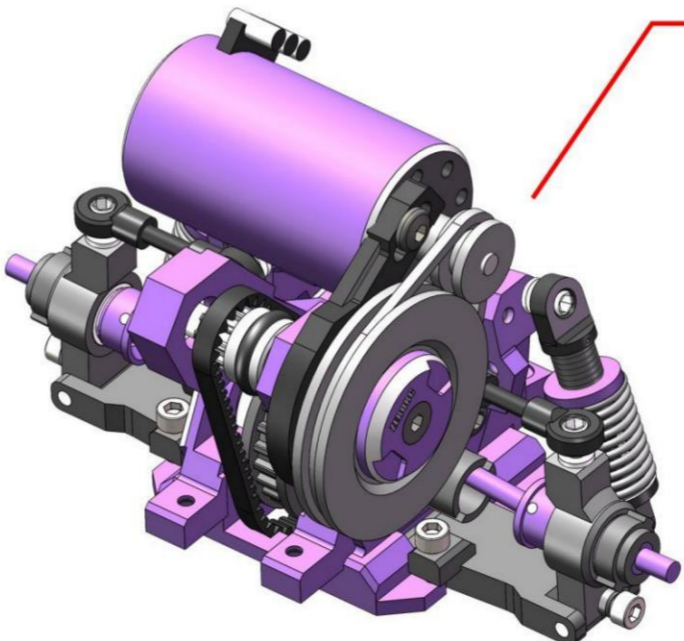

Gear transmission installation method

齿轮传动安装方式

请注意，齿轮之间的间隙不应过紧。
Please note that the clearance between the gears should not be too tight.

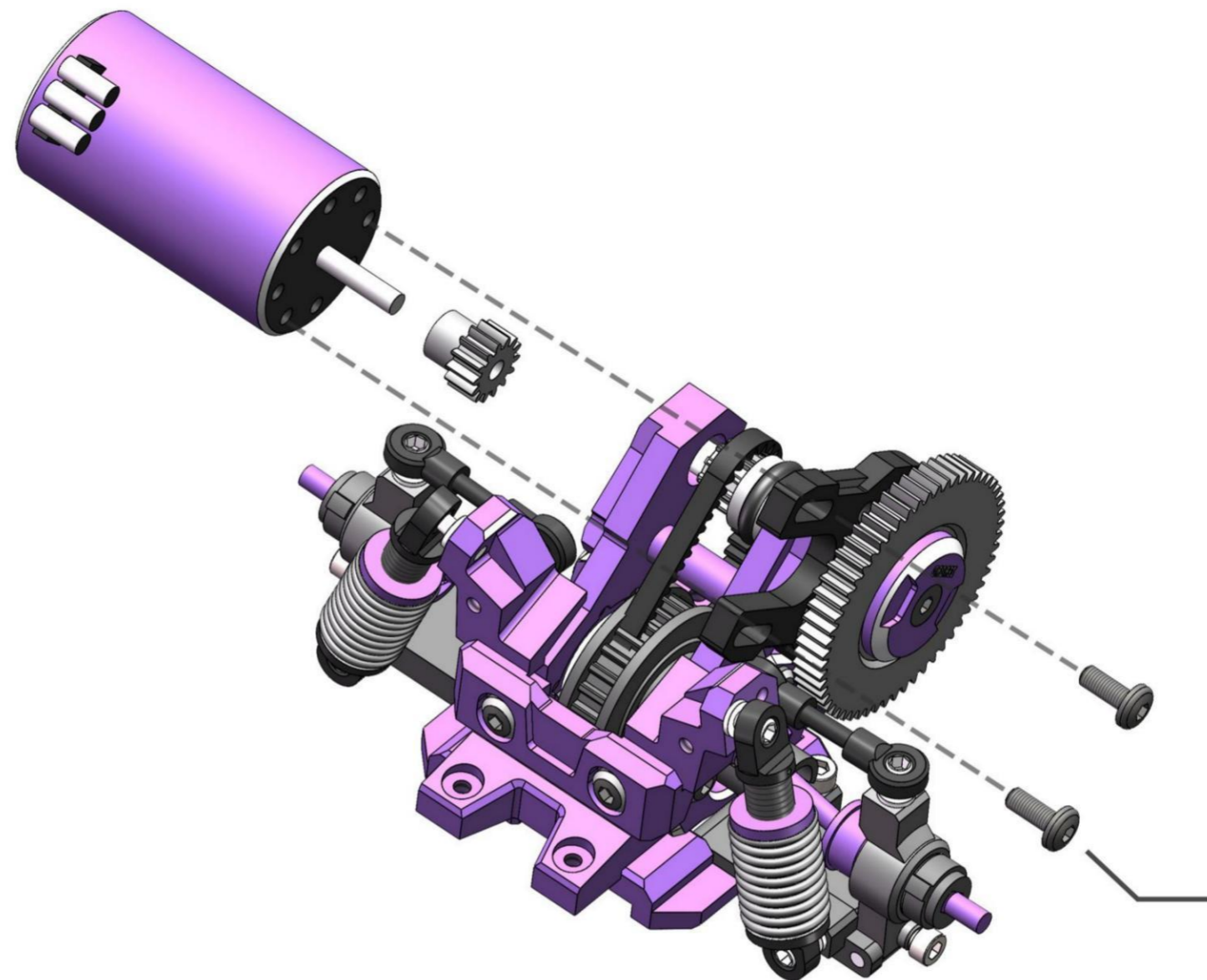
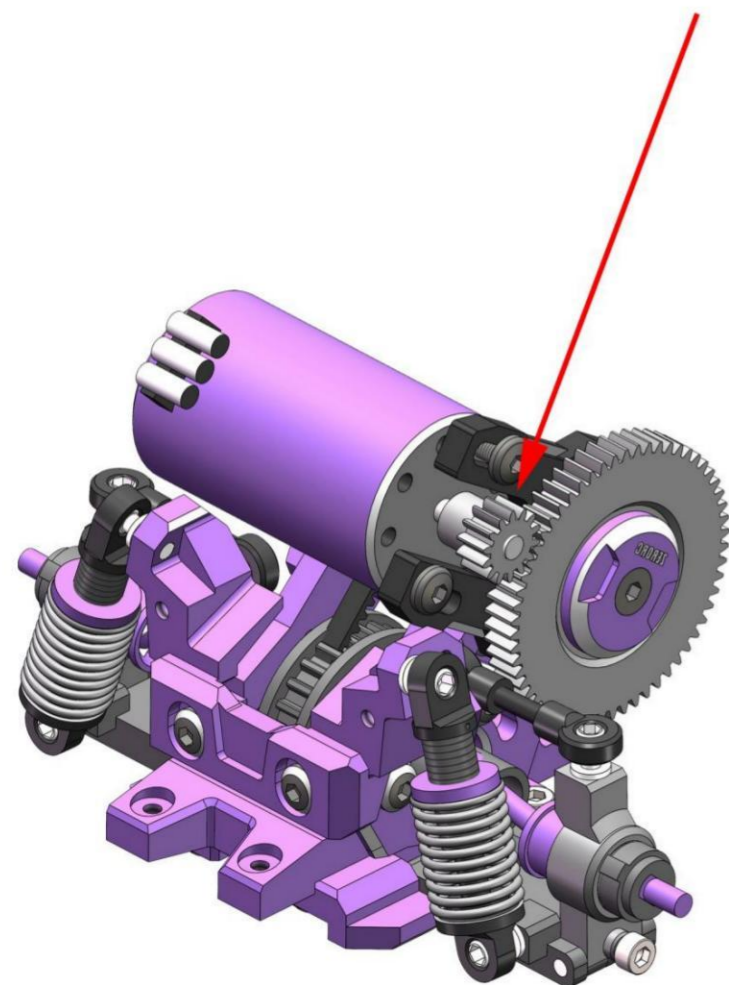

2- M2x5
RH Screw

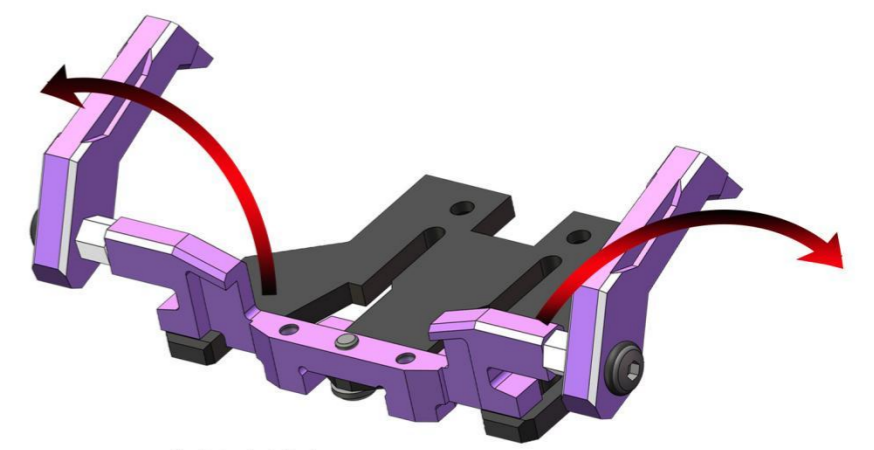
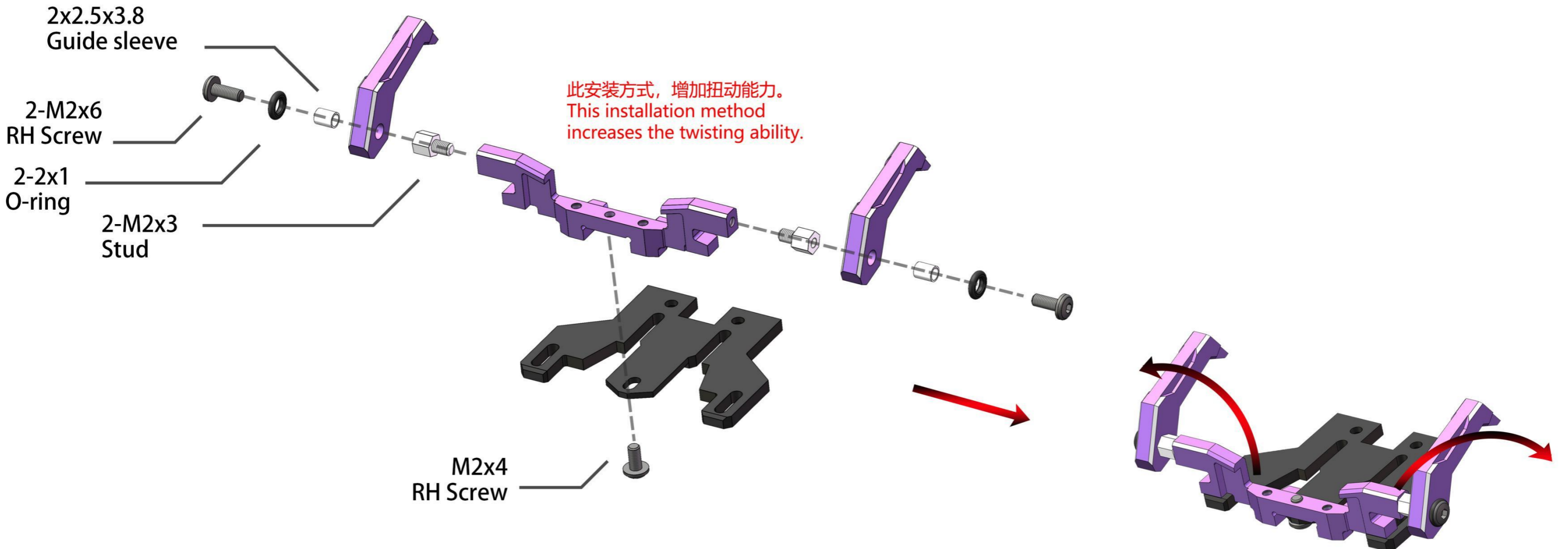

高扭动状态
High twisting state

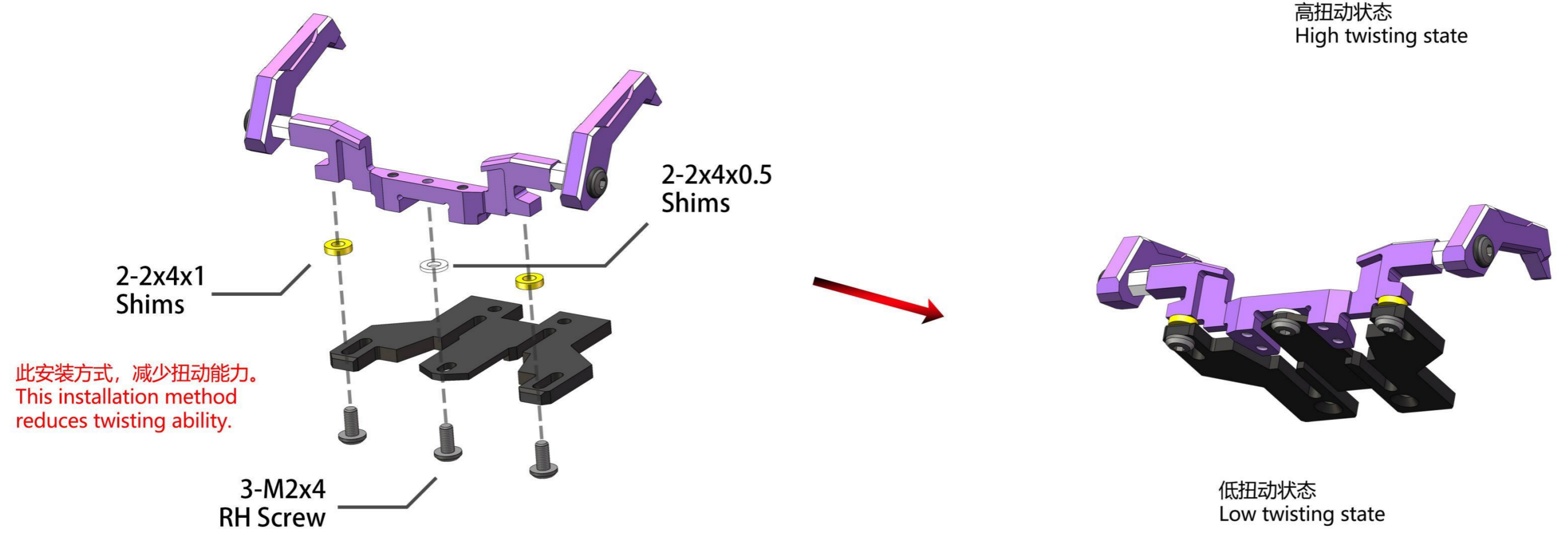

低扭动状态
Low twisting state

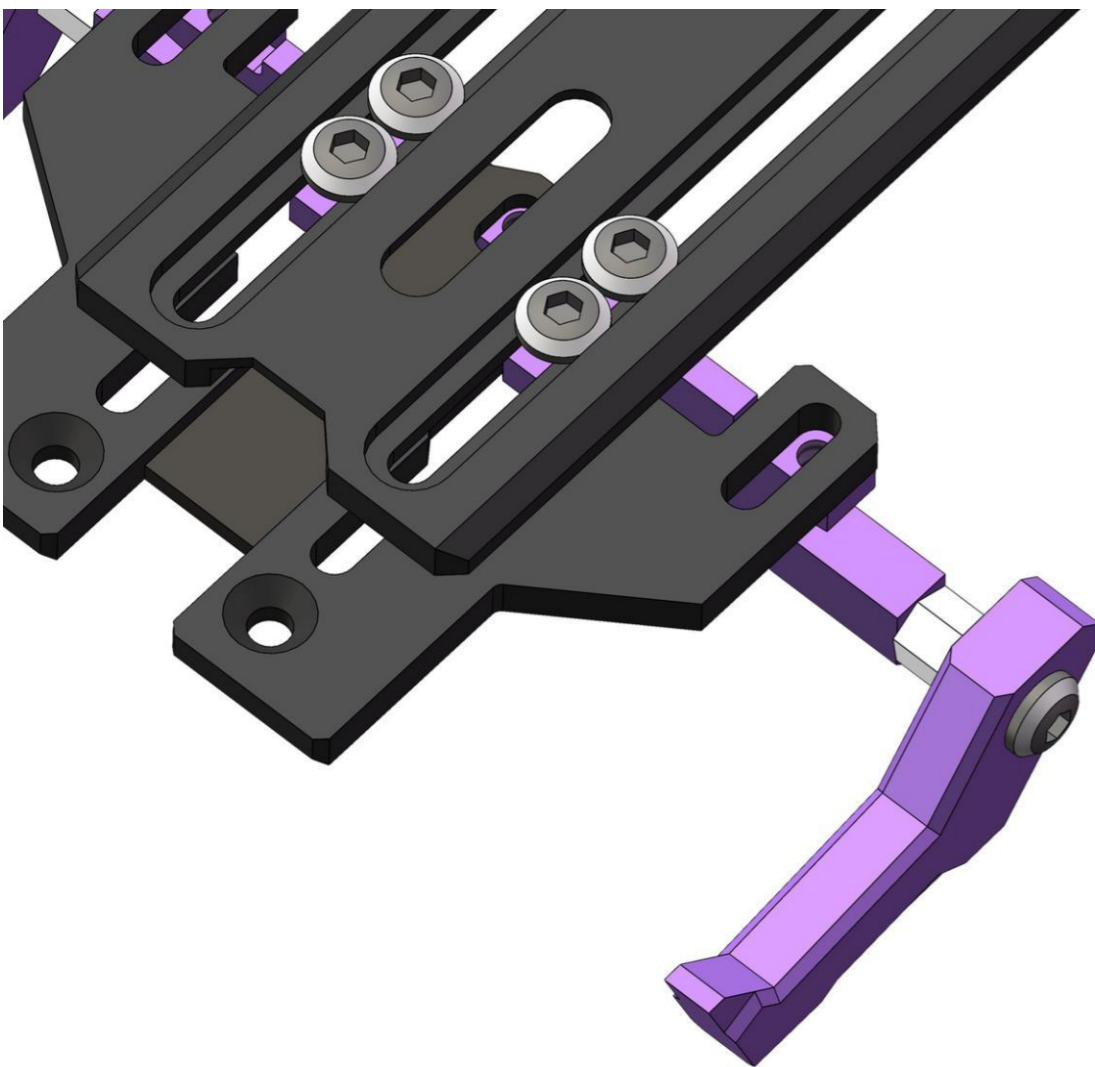

High traction bottom plate

高牵引力底板

Increase the adjustable torsion of the base plate to improve traction.
增加底板的可调整扭动性，提高牵引力。

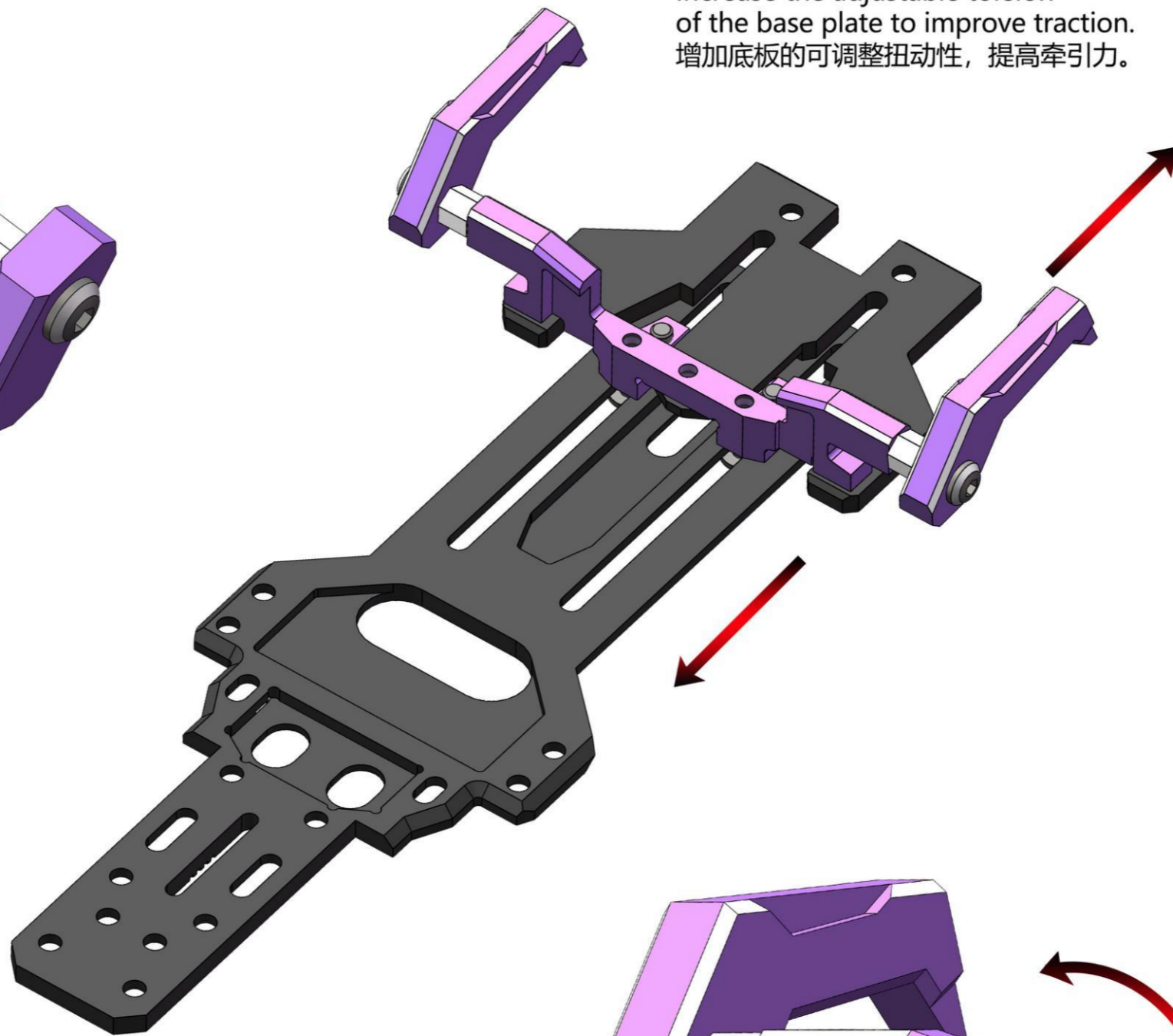

Adjustable left and right twisting
可调式左右扭动

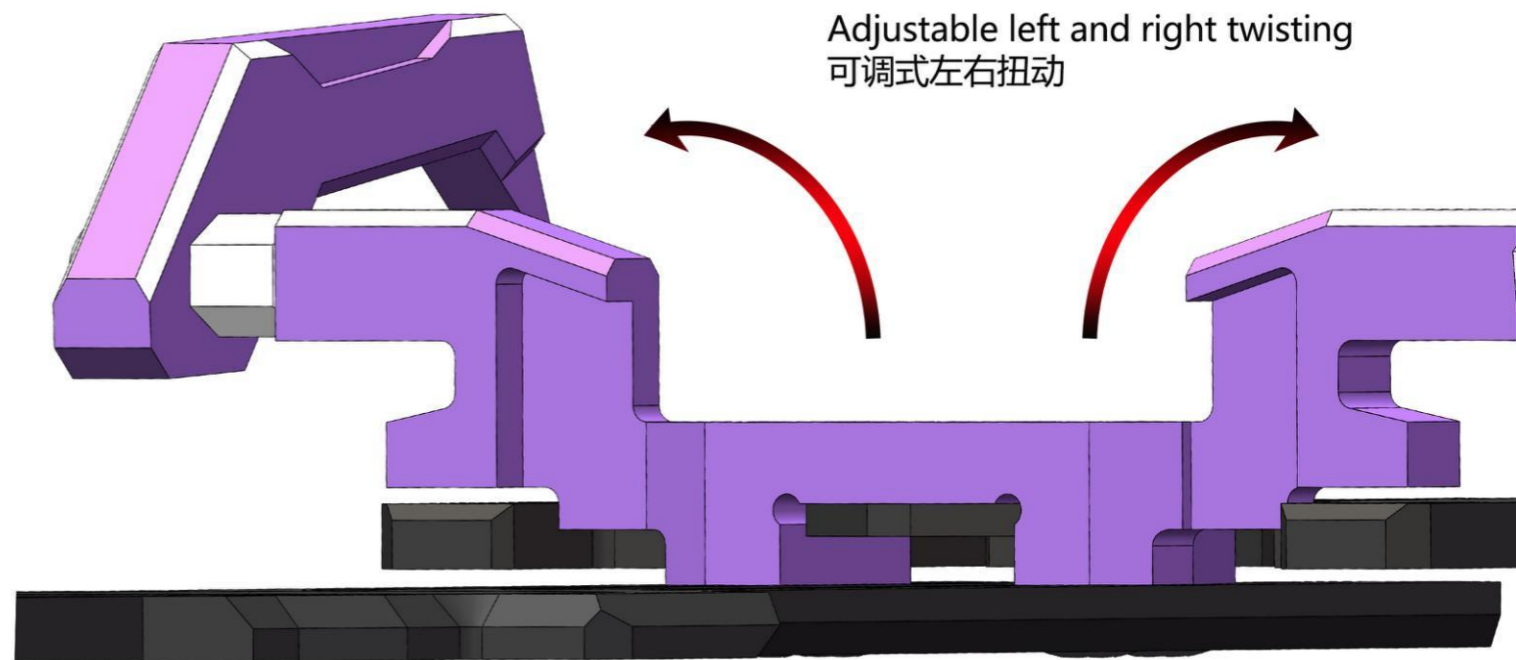

ZERORC
WWW.ZERO-RC.COM

RW00 SR

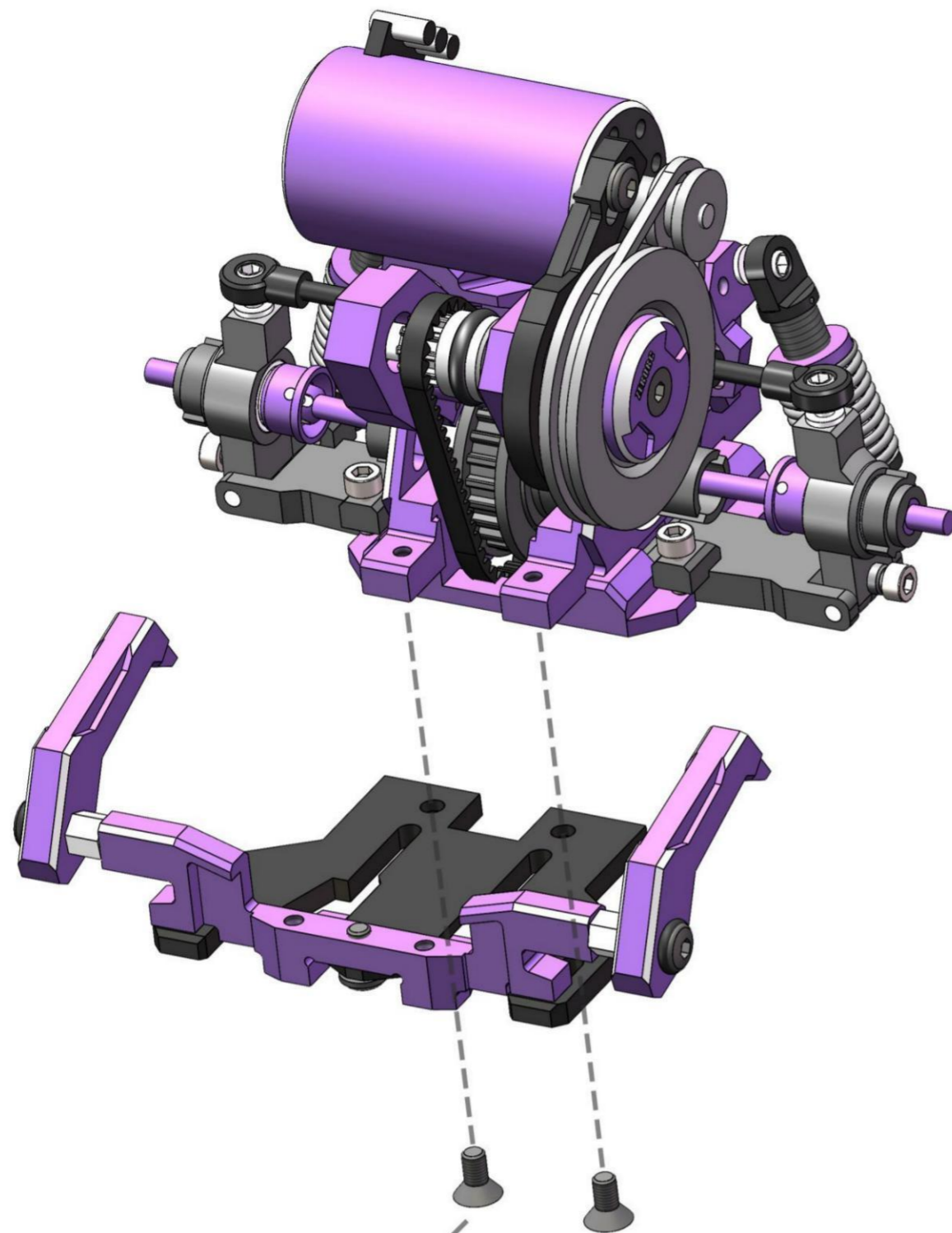

2-M2x4
CS Screw

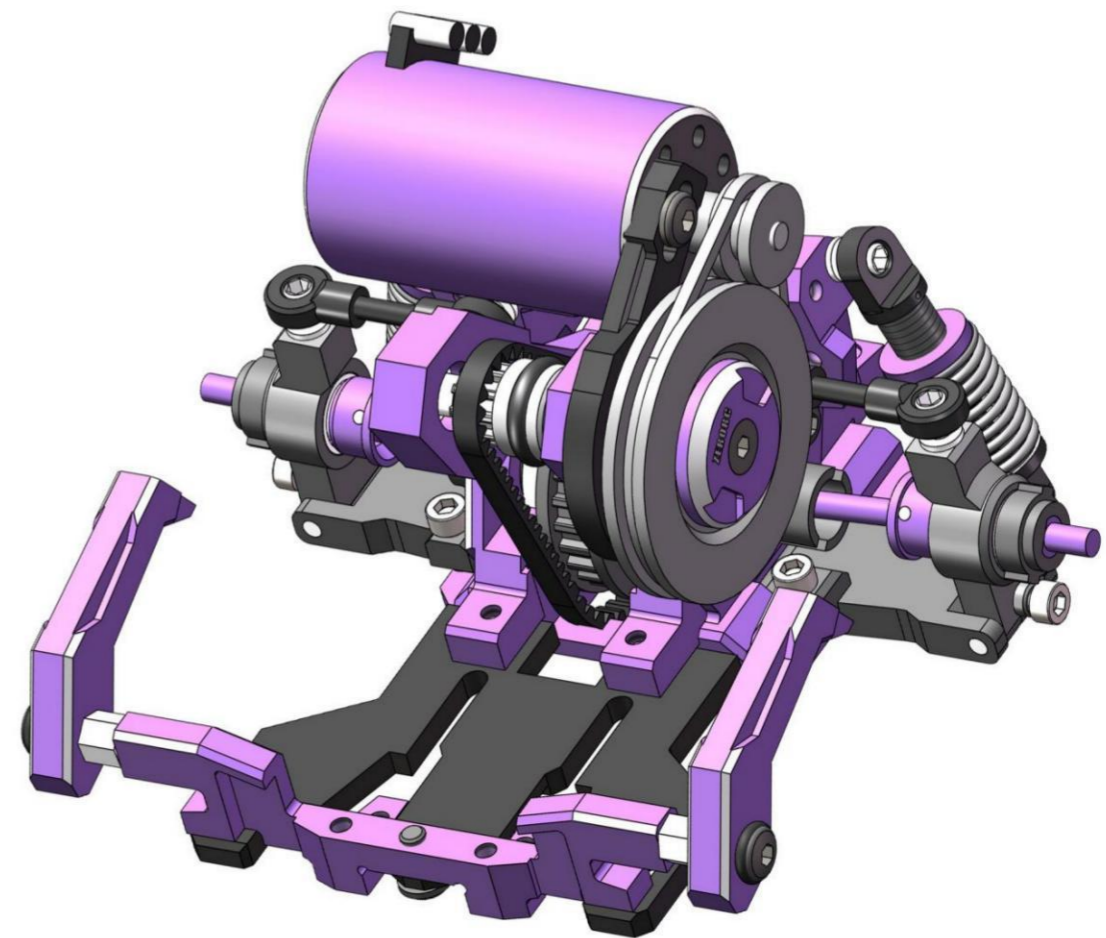

4-M2x4
RH Screw

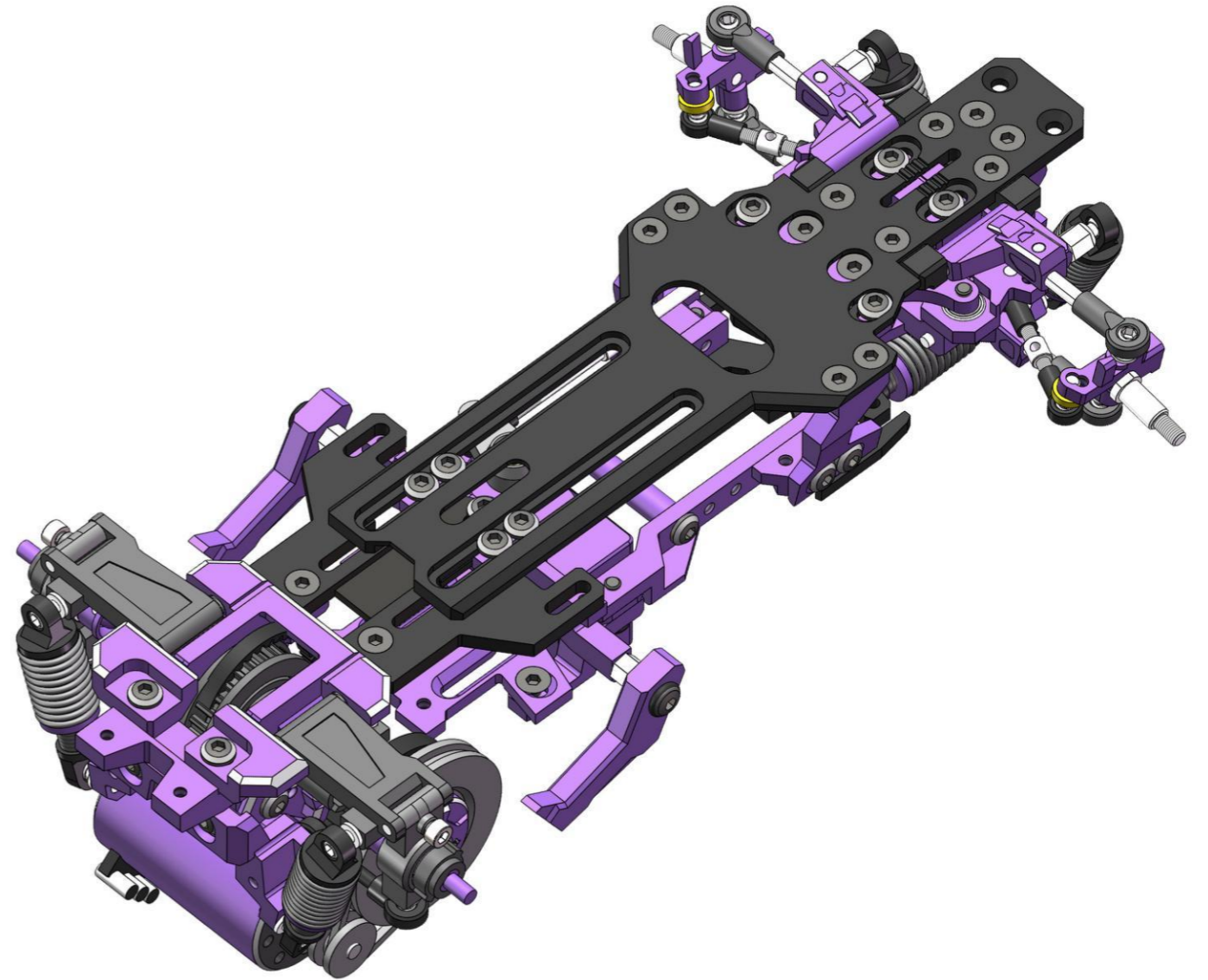
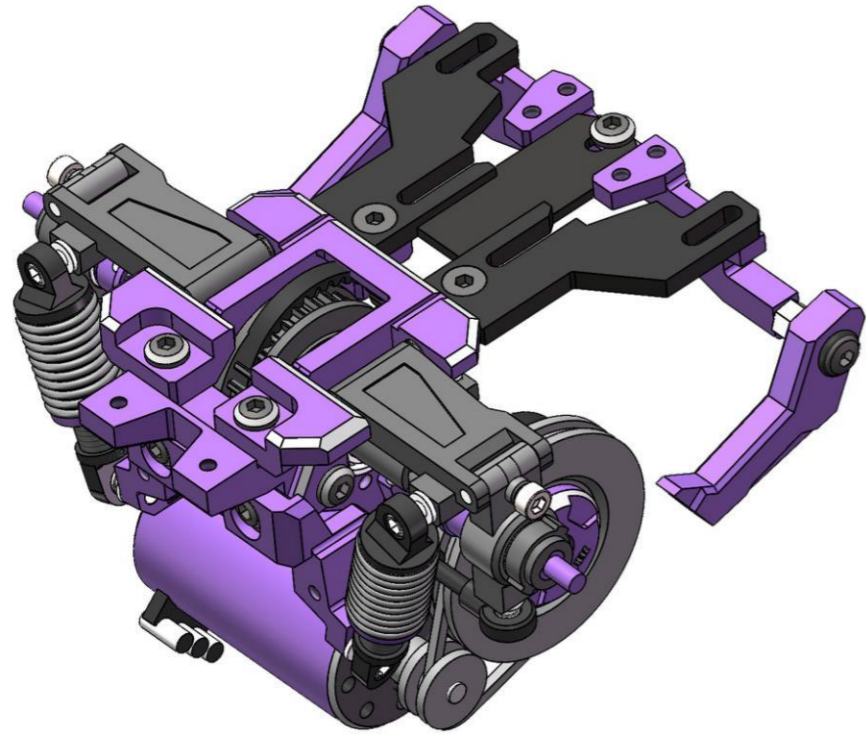
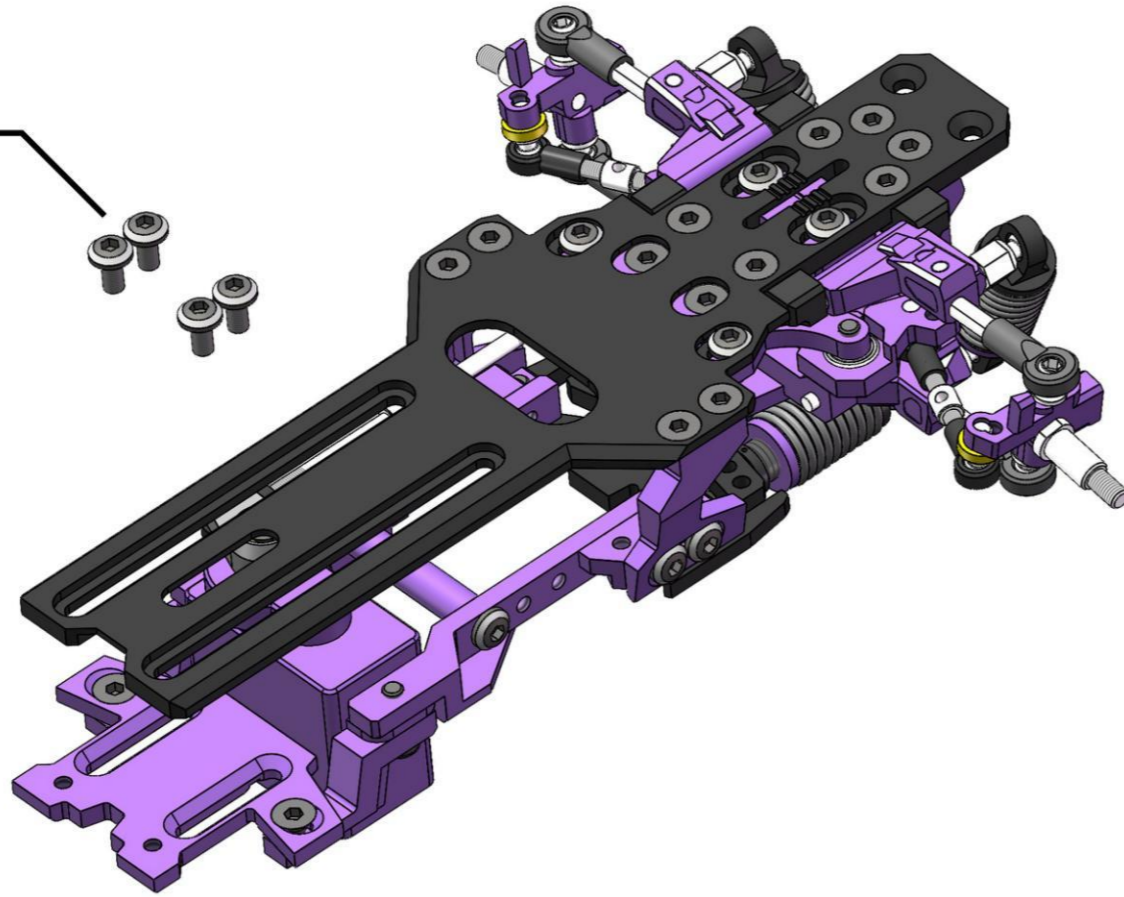
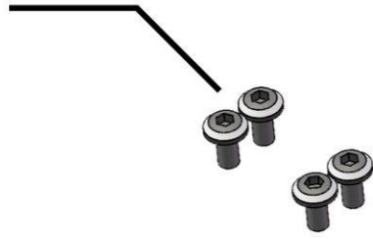

2-M2x6
Set Screw

2-3x8
Magnet
磁铁

2-M2x5
RH Screw

2-M2x10
Aluminum column
铝柱

2-M2x5
RH Screw

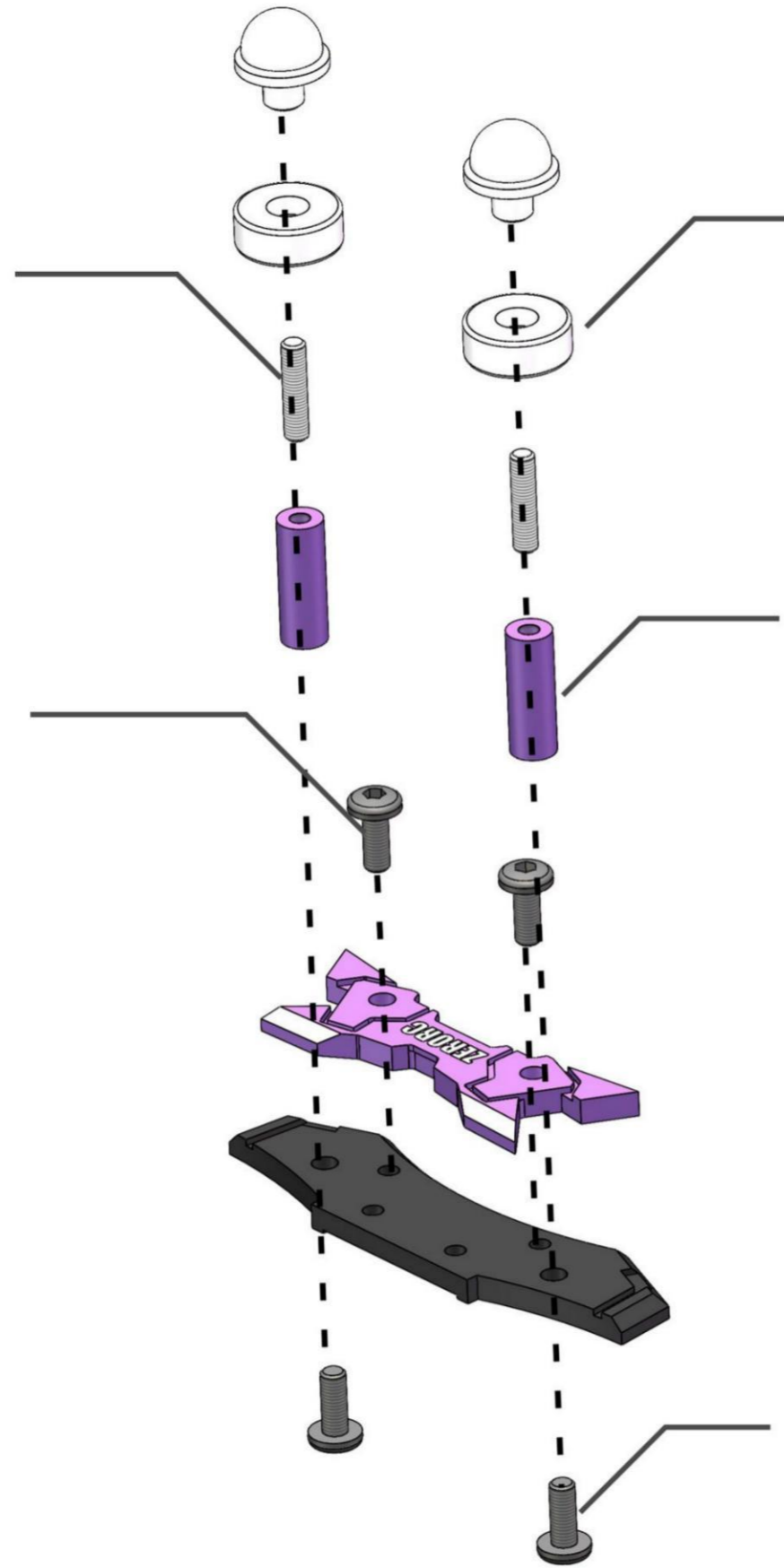

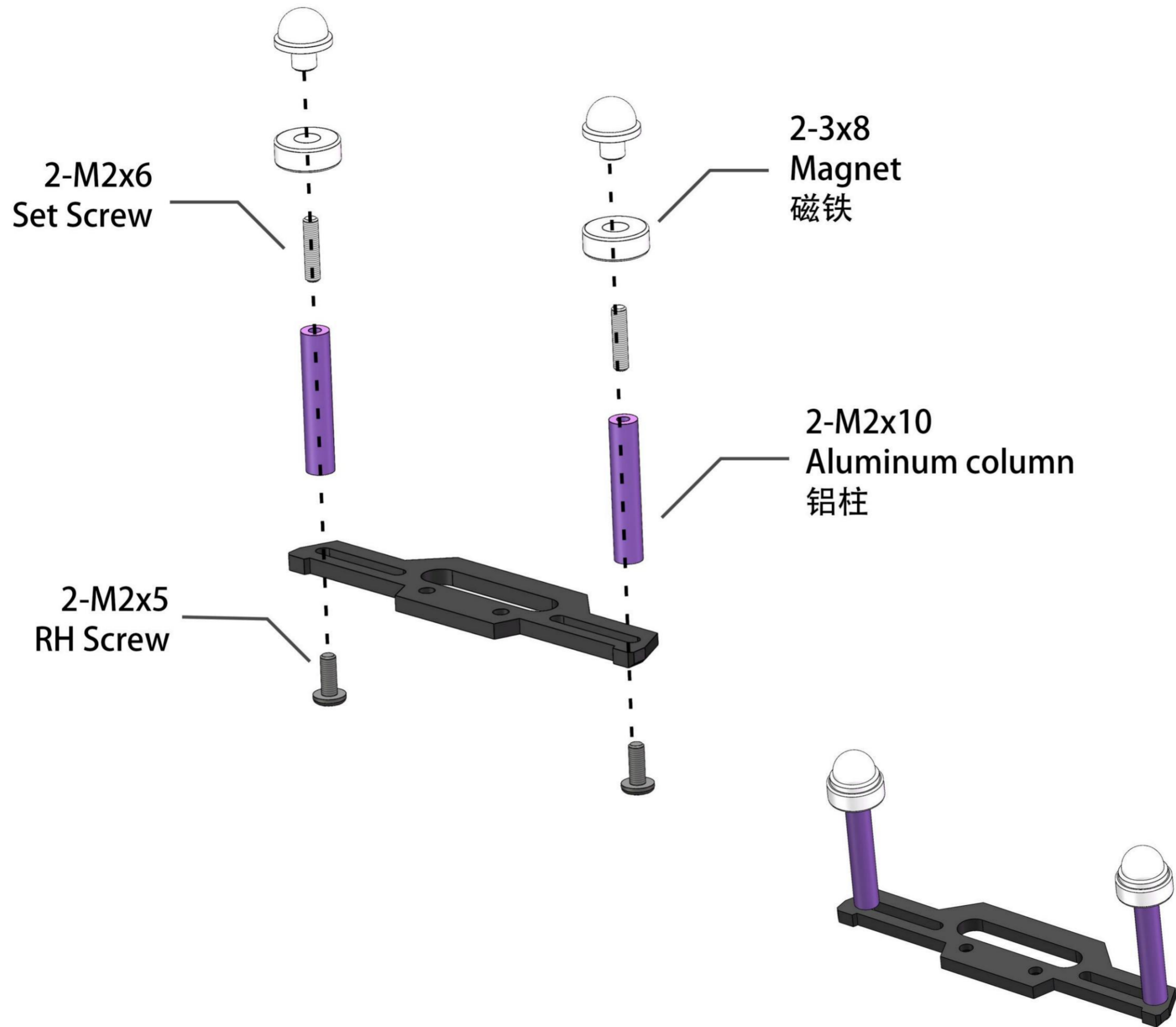

4-M2x4
CS Screw

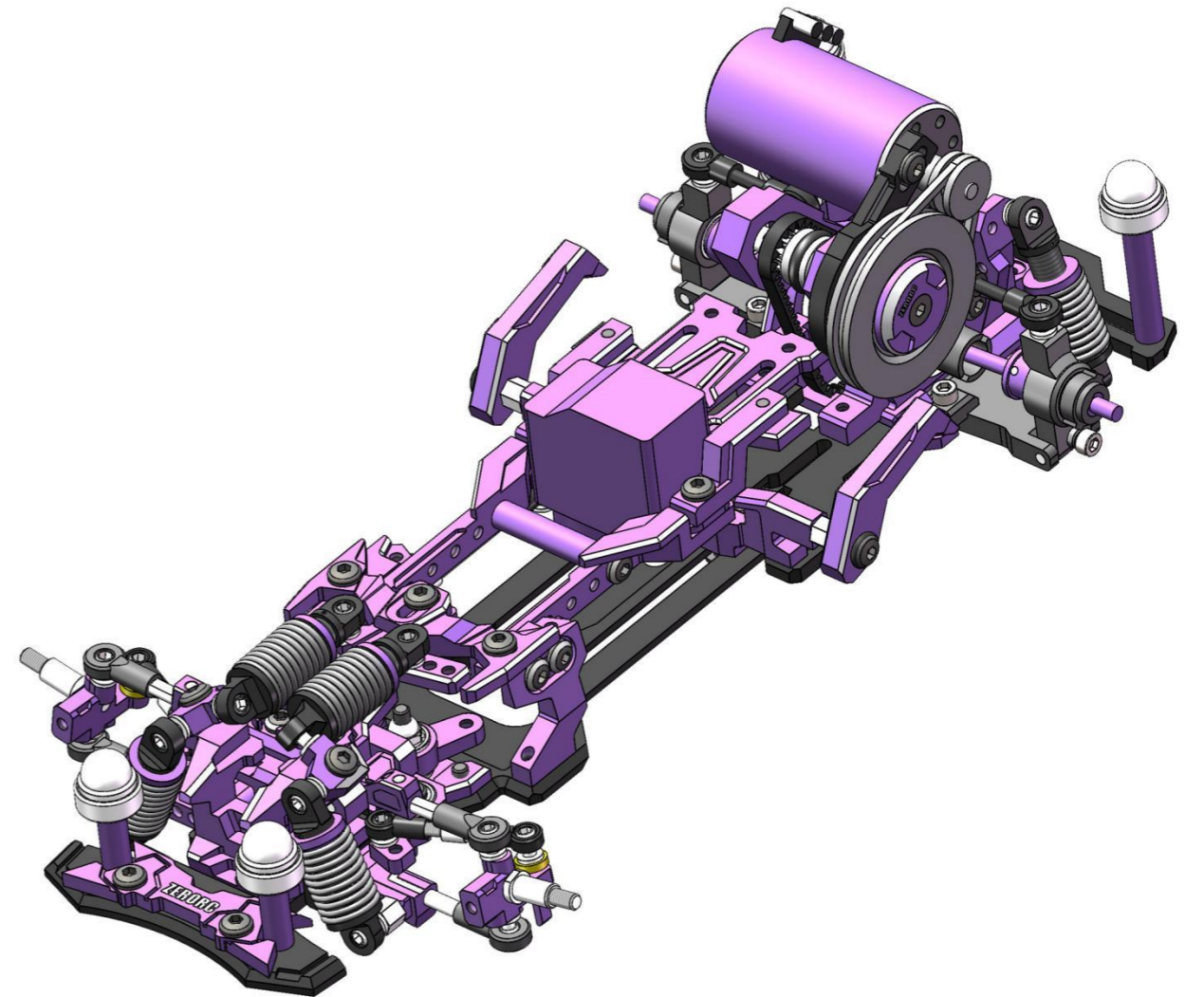
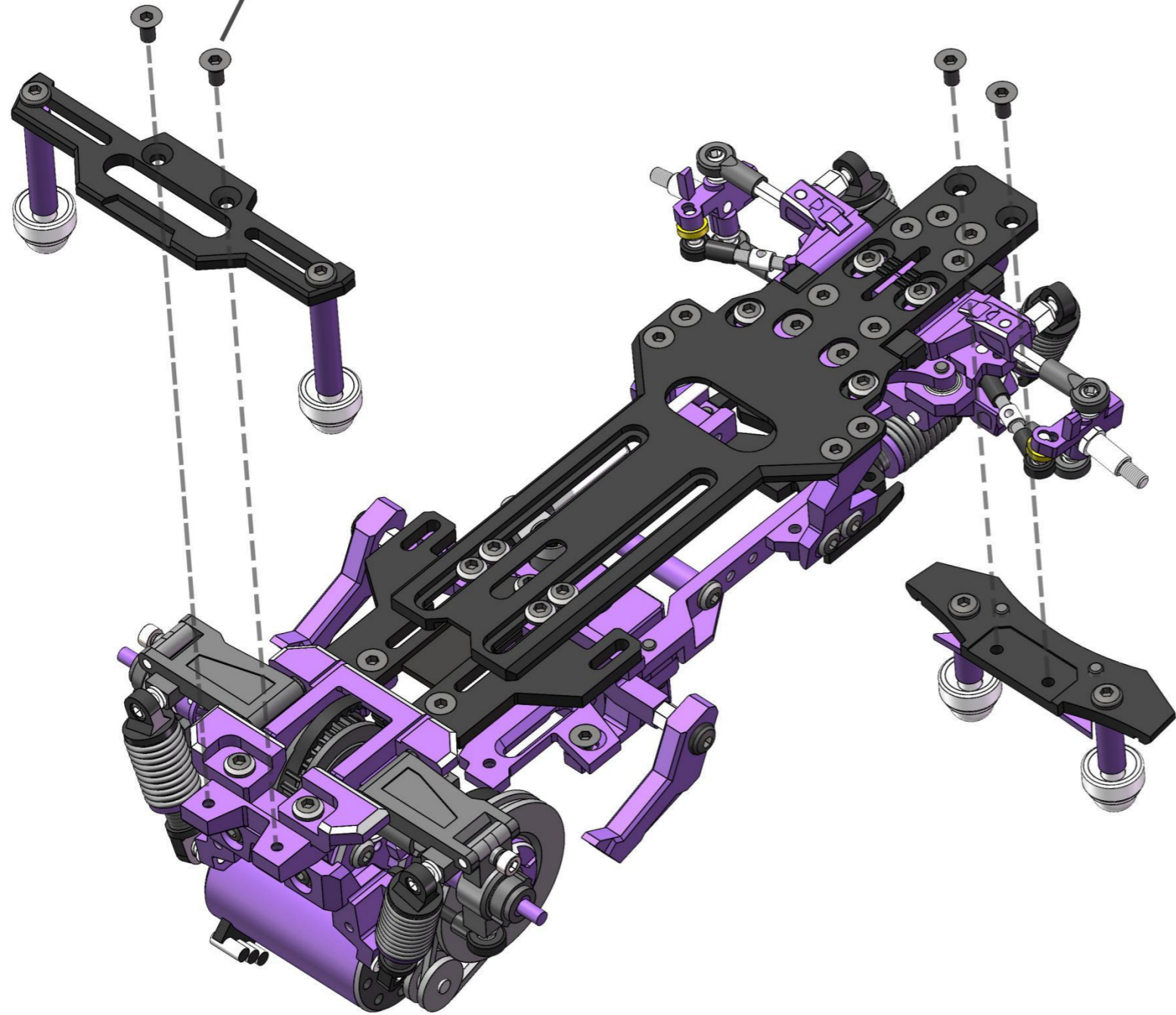

ESC

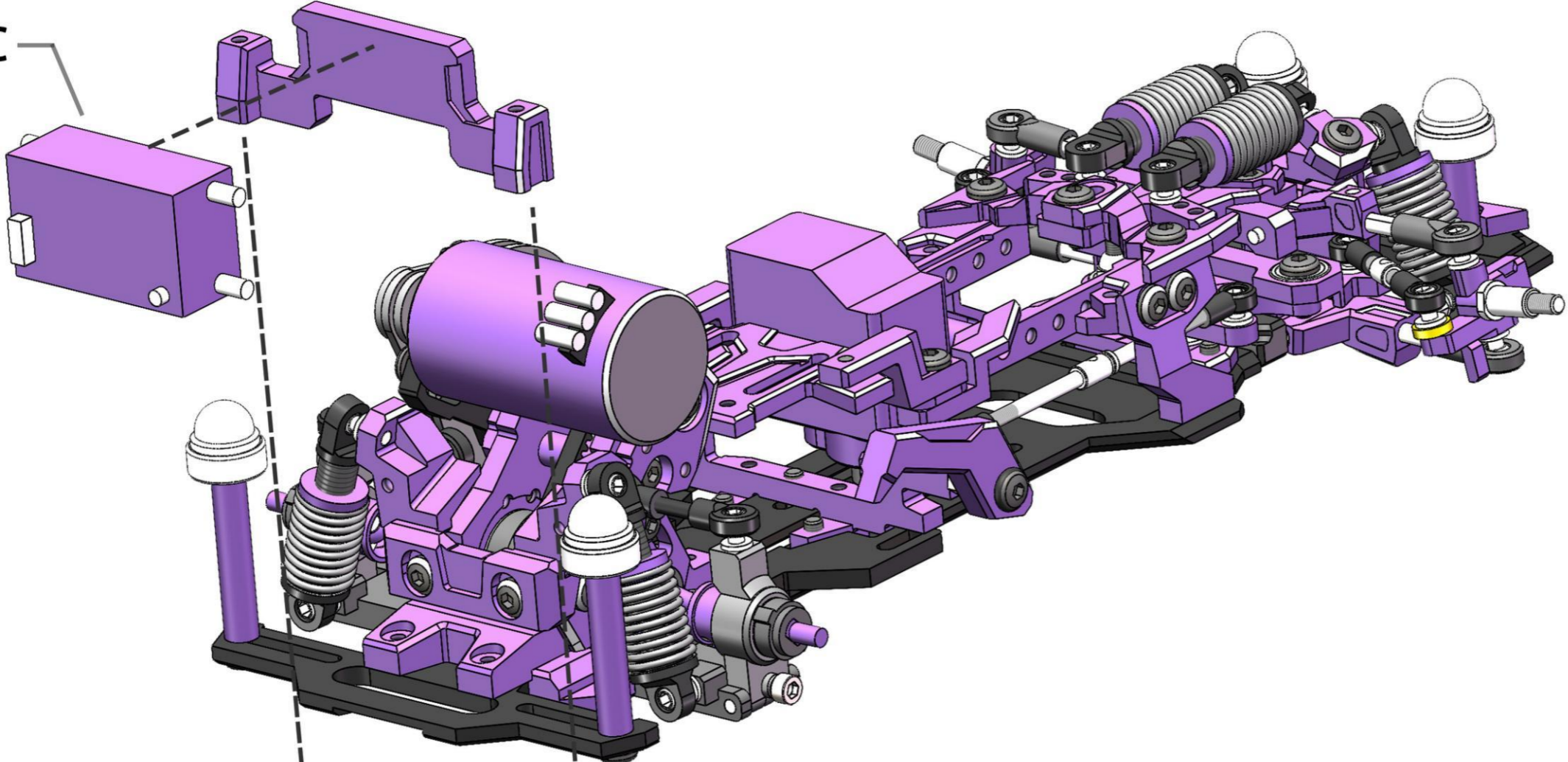

2-M2x5
RH Screw

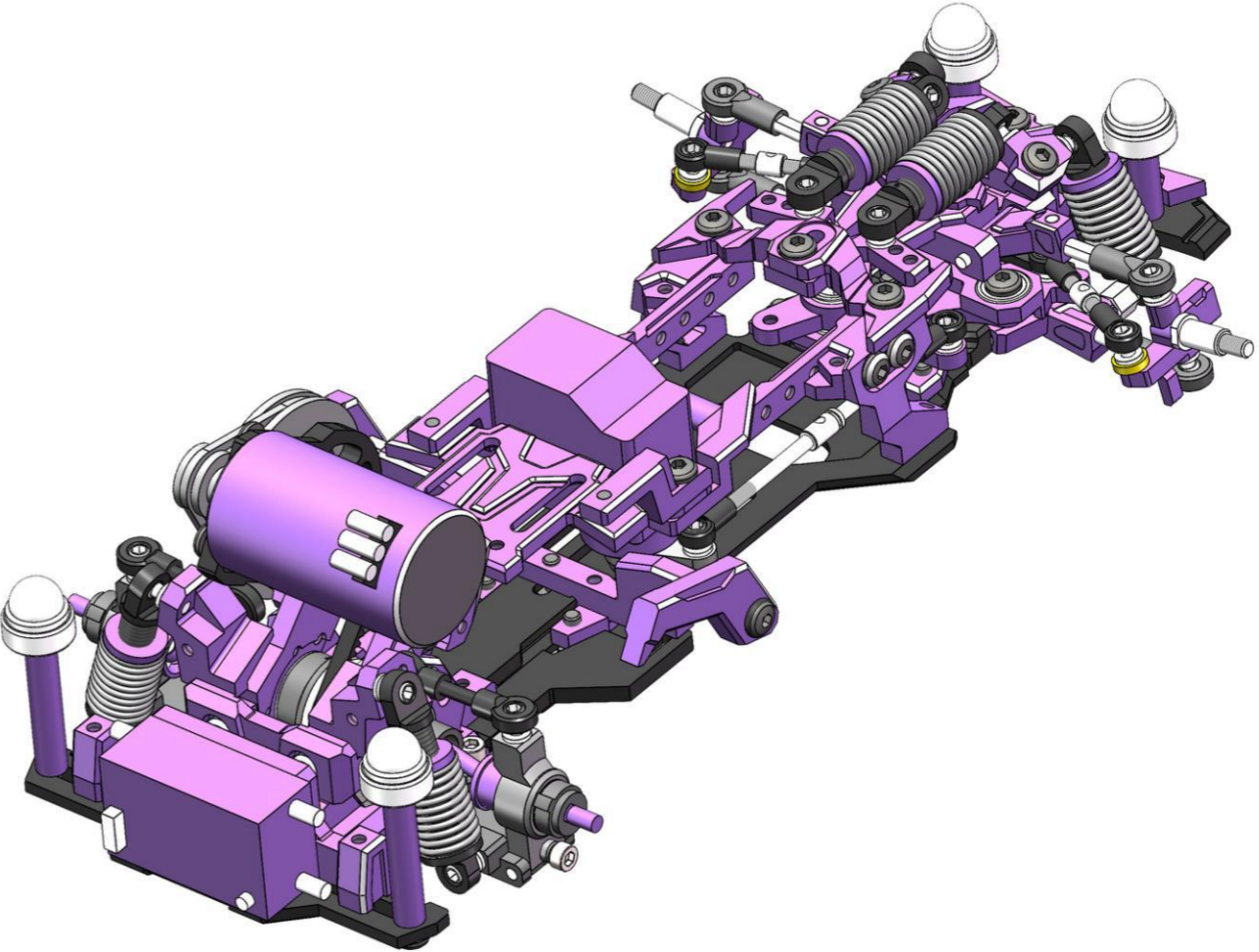

Left and right symmetrical installation

左右对称安装

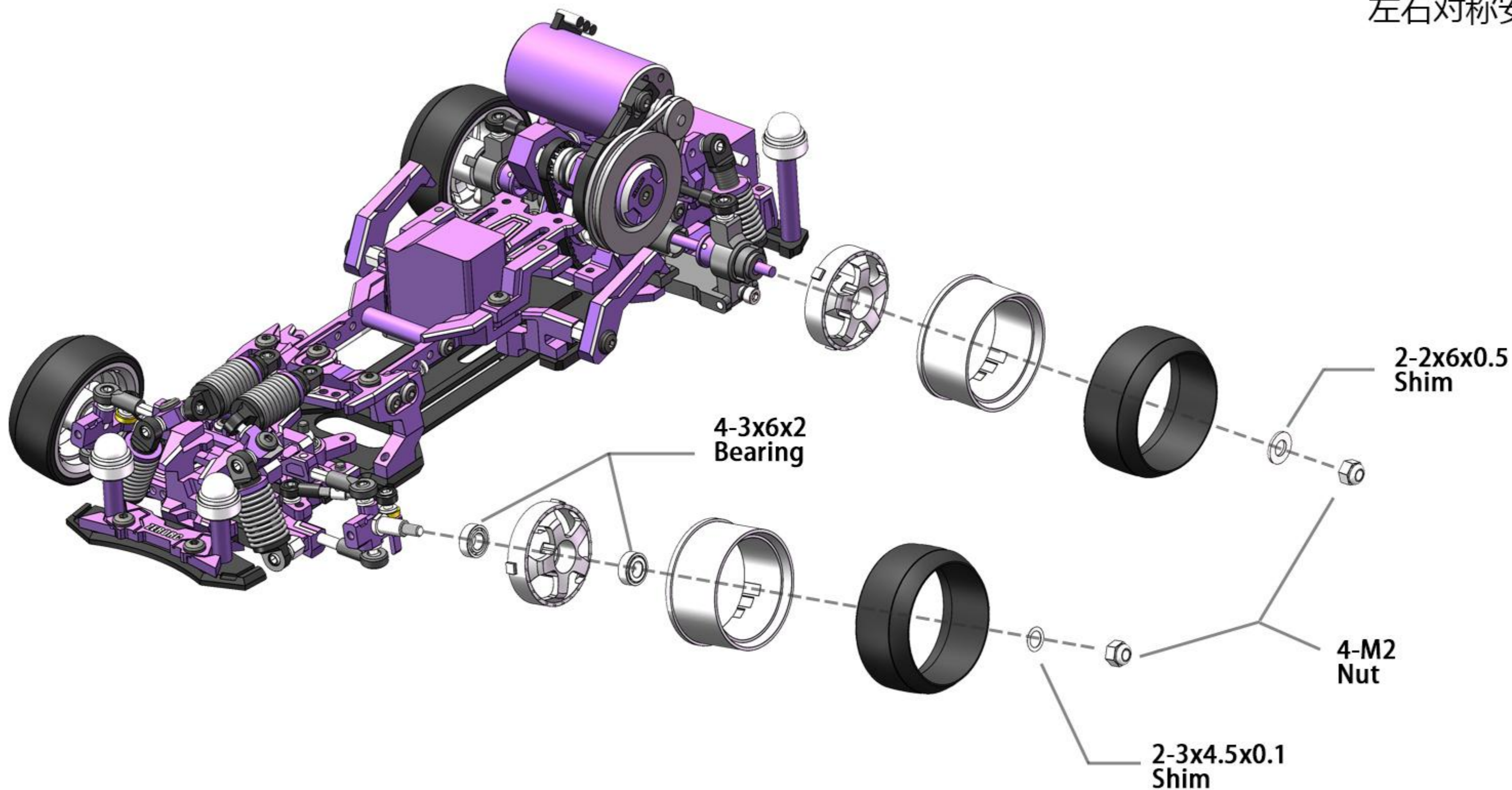

根据实际情况选择安装垫片的数量；
优先考虑平滑度，并尽可能减少间隙，
Select the number of installation gaskets
according to the actual situation；
Prioritize smoothness and minimize
gaps as much as possible.

Completion

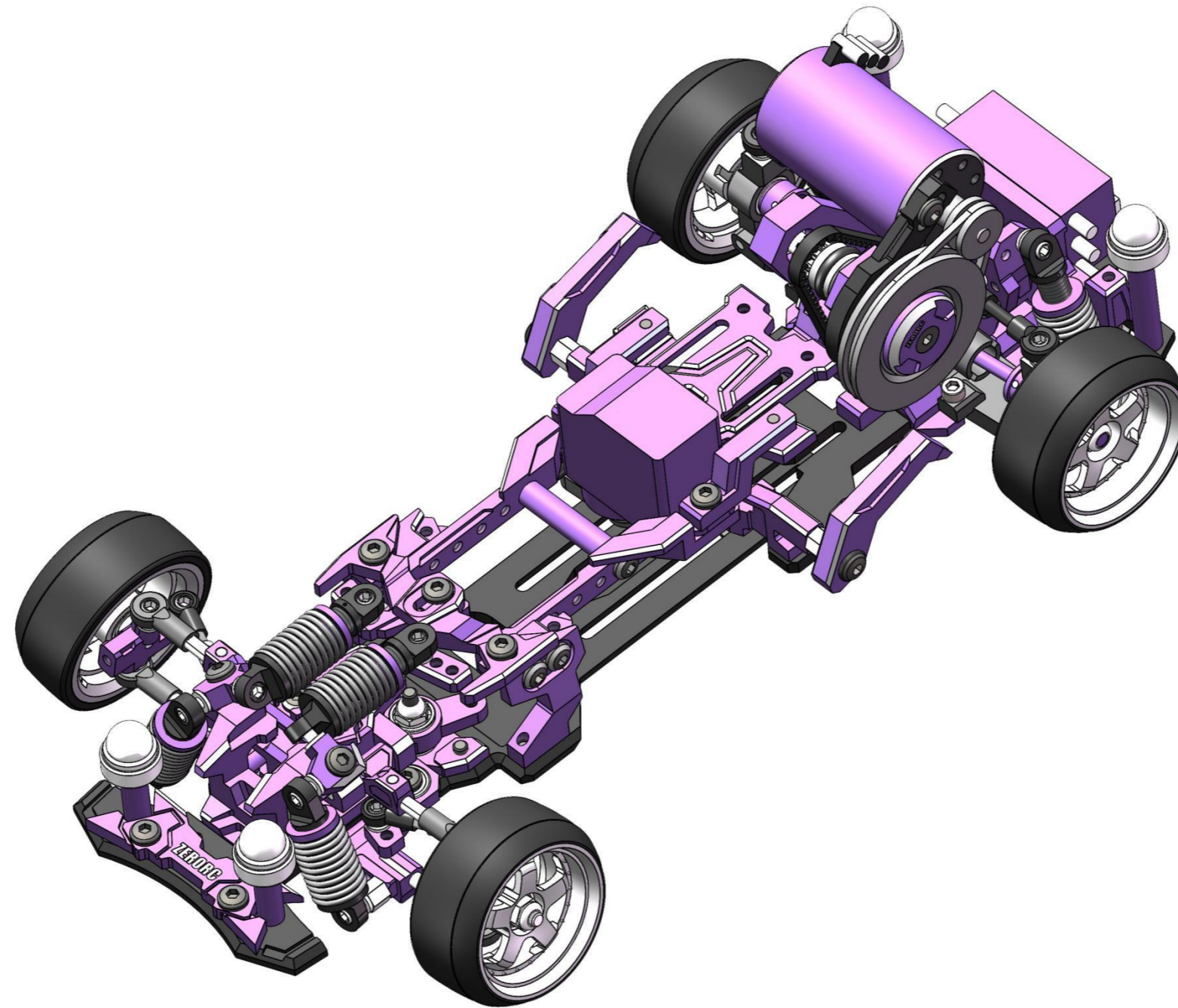

— 03

Options
accessories
选装配件

Rear two-stage suspension

后双段式避震

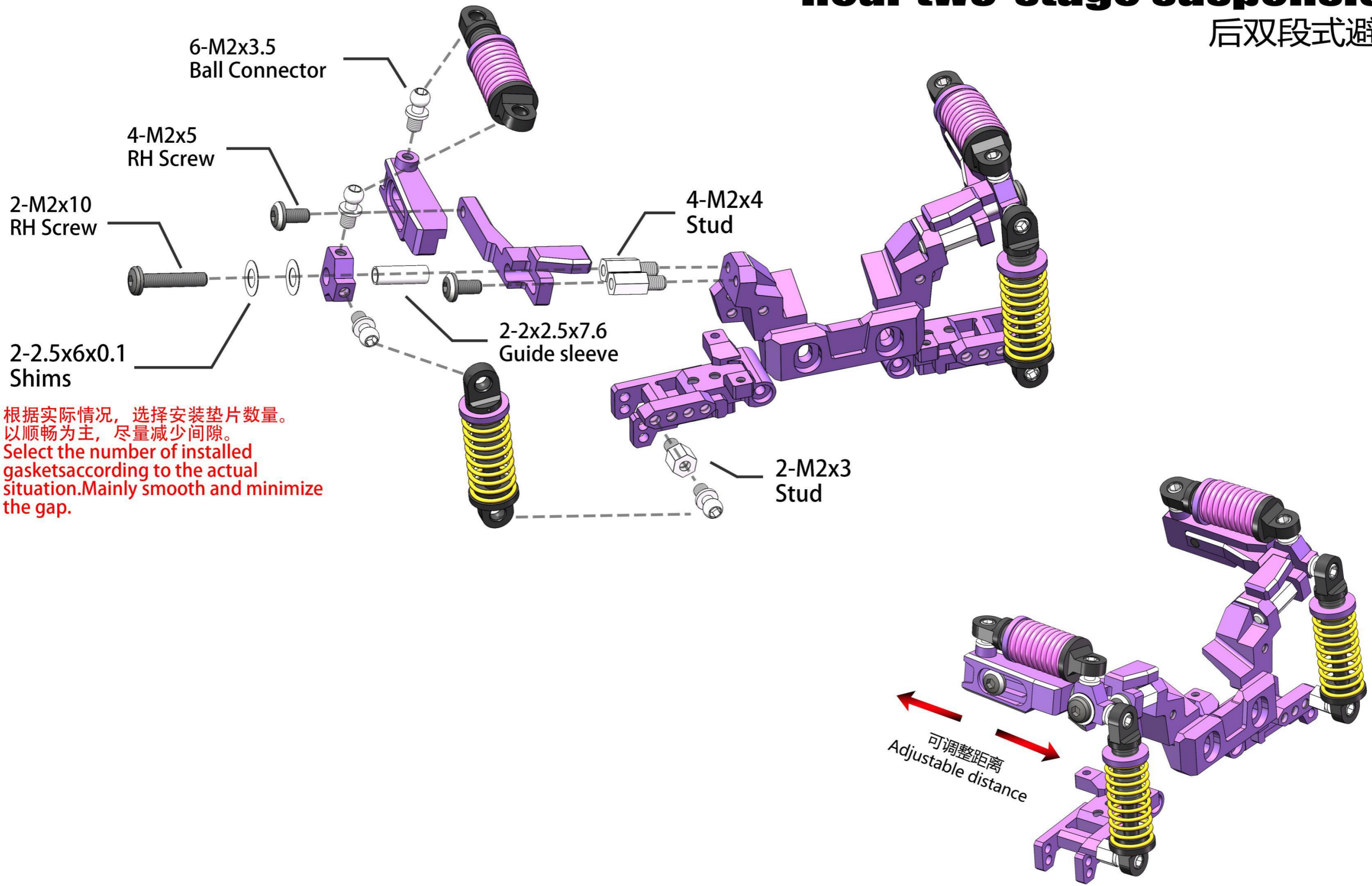

根据实际情况，选择安装垫片数量。
以顺畅为主，尽量减少间隙。
Select the number of installed gaskets according to the actual situation. Mainly smooth and minimize the gap.

可调整距离
Adjustable distance



Adjustable exhaust shock

可调排气避震器

Add bearings to enhance the initial spring response.
增加轴承, 提升初段弹簧反应。

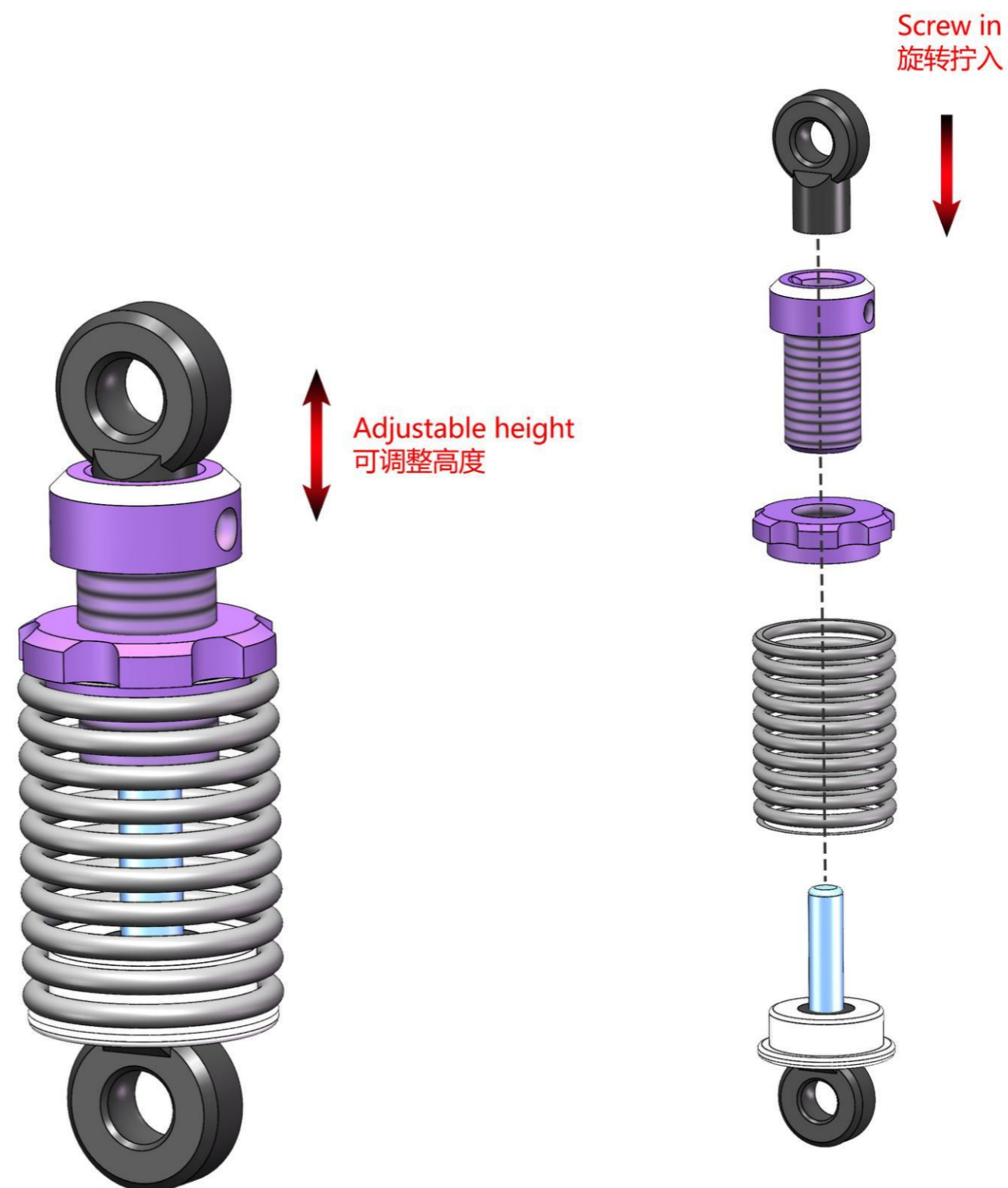
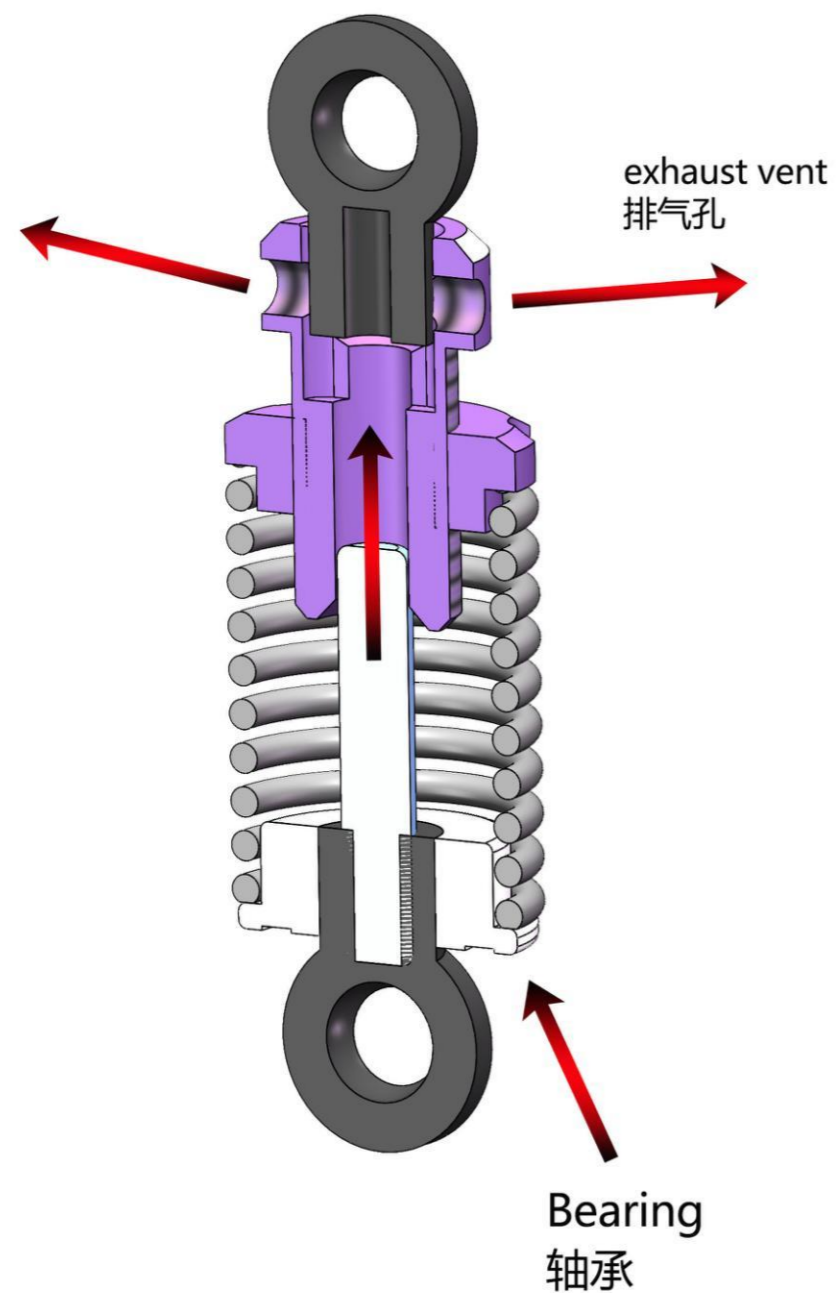

Options Front axle

OP前轮轴安装

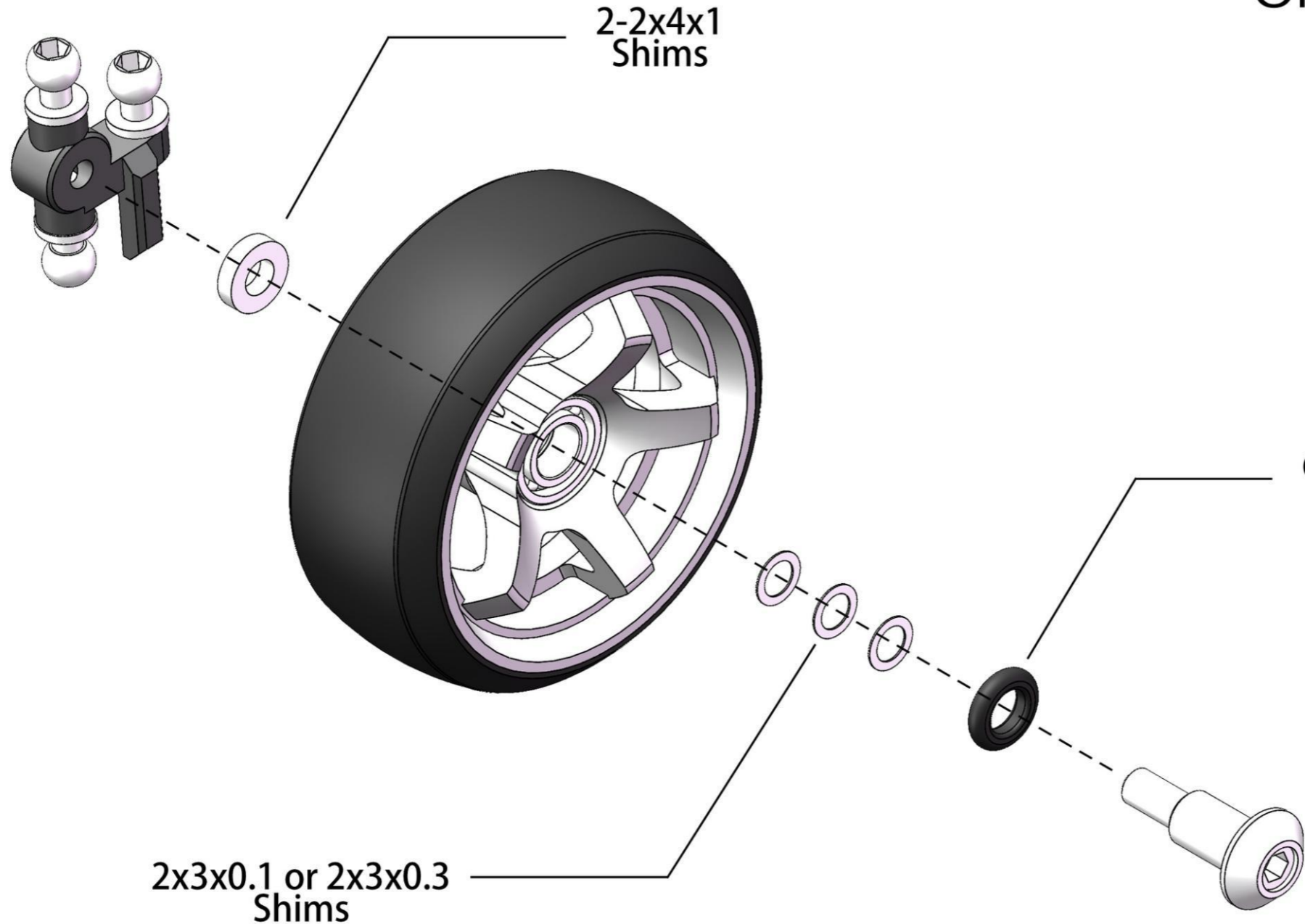

选择性安装，安装后可以增加前轮牵引力。

Selective installation can increase the traction of the front wheels after installation.

如果安装后，出现太紧或者太松的情况，可以调整此如垫片数量。

If there is a situation of being too tight or too loose after installation, the number of gaskets can be adjusted.



HIGH TRACTION SHOCK

高牵引力避震器

根据实际情况，选择安装垫片数量。
以顺畅为主，尽量减少间隙。

Select the number of installed gaskets according
to the actual situation. Mainly smooth
and minimize the gap.

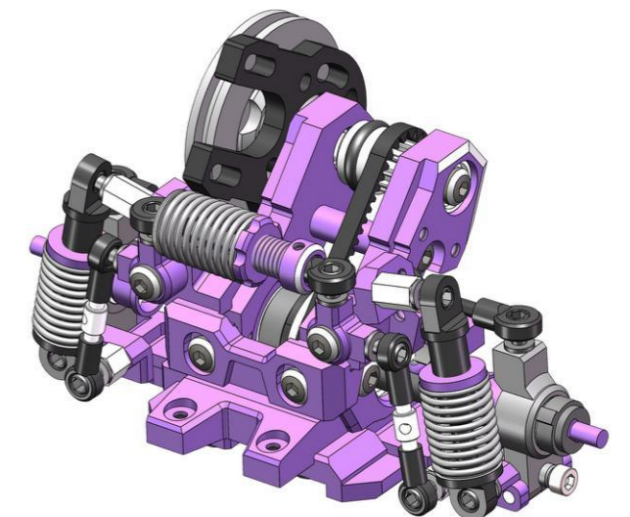
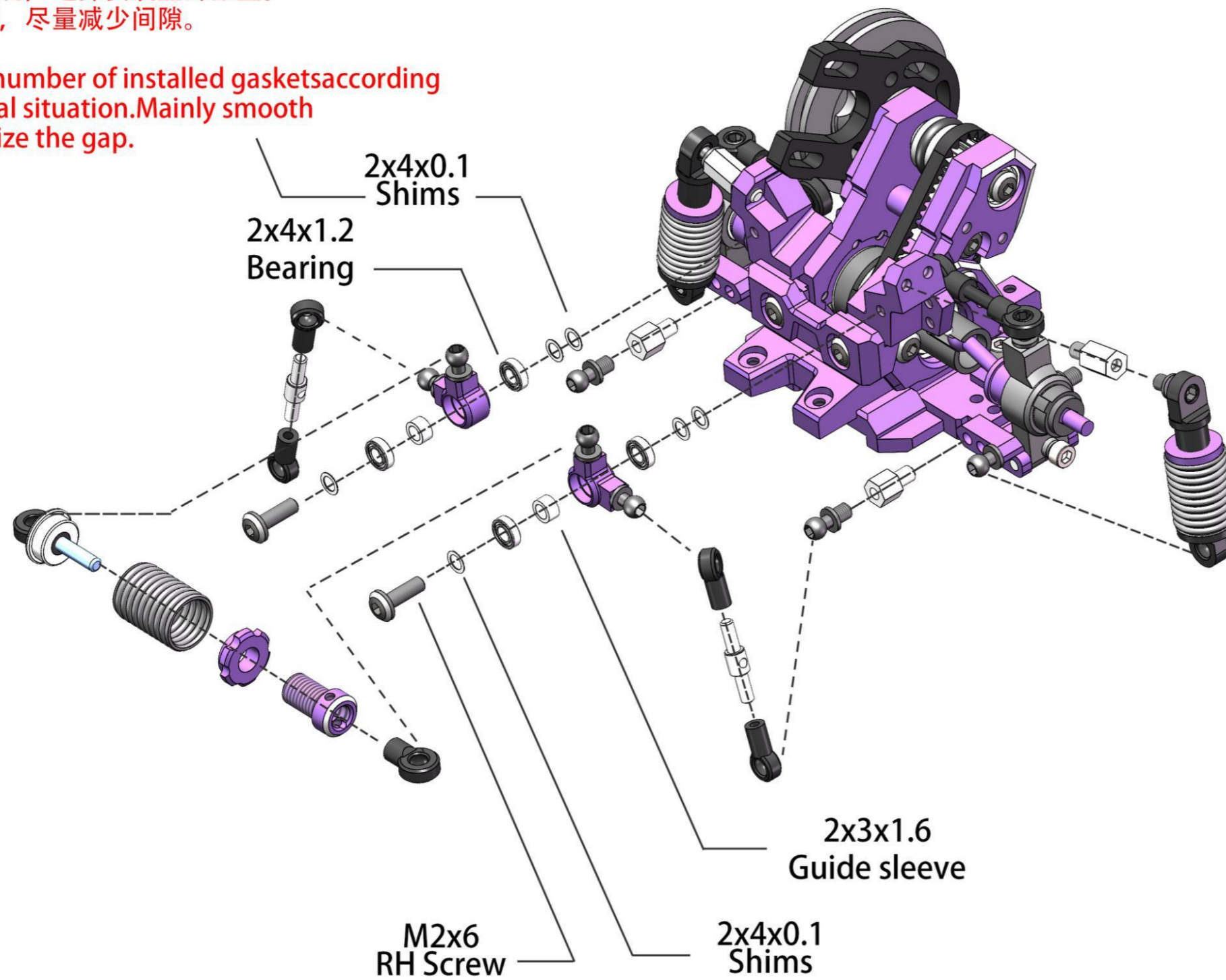

Optional metal combiner

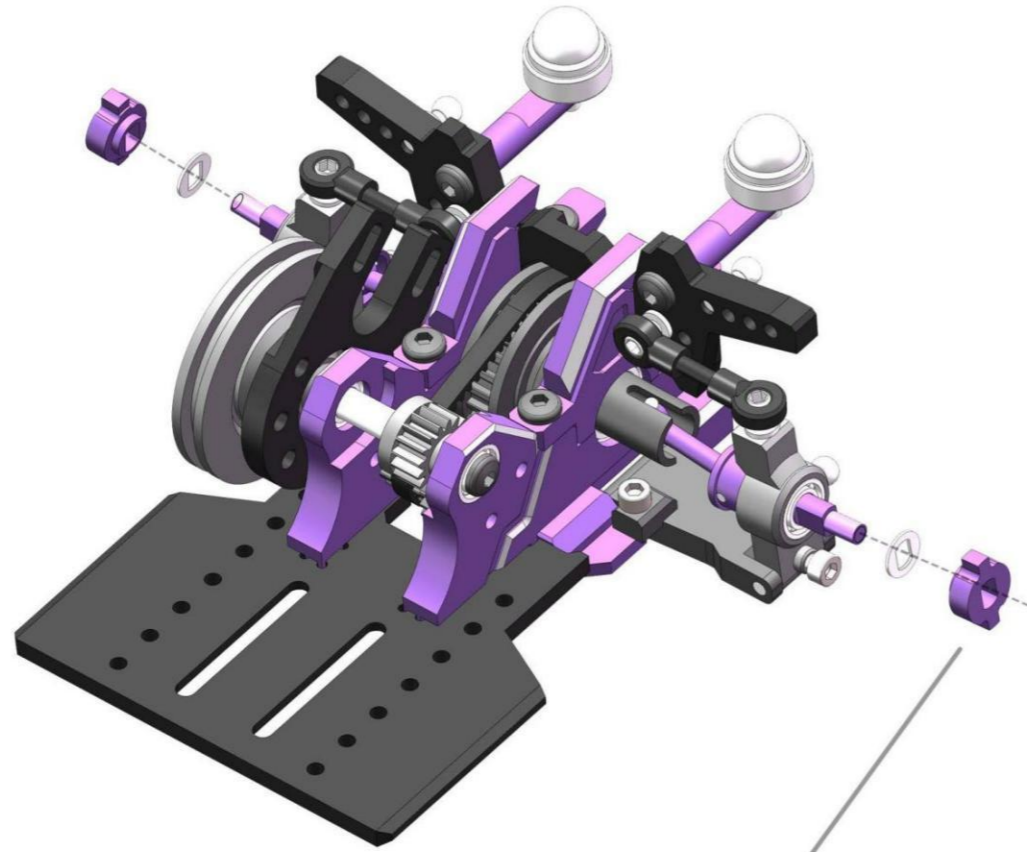

可正反安装，提供不同宽度。
It can be installed in front and back,
with different widths.

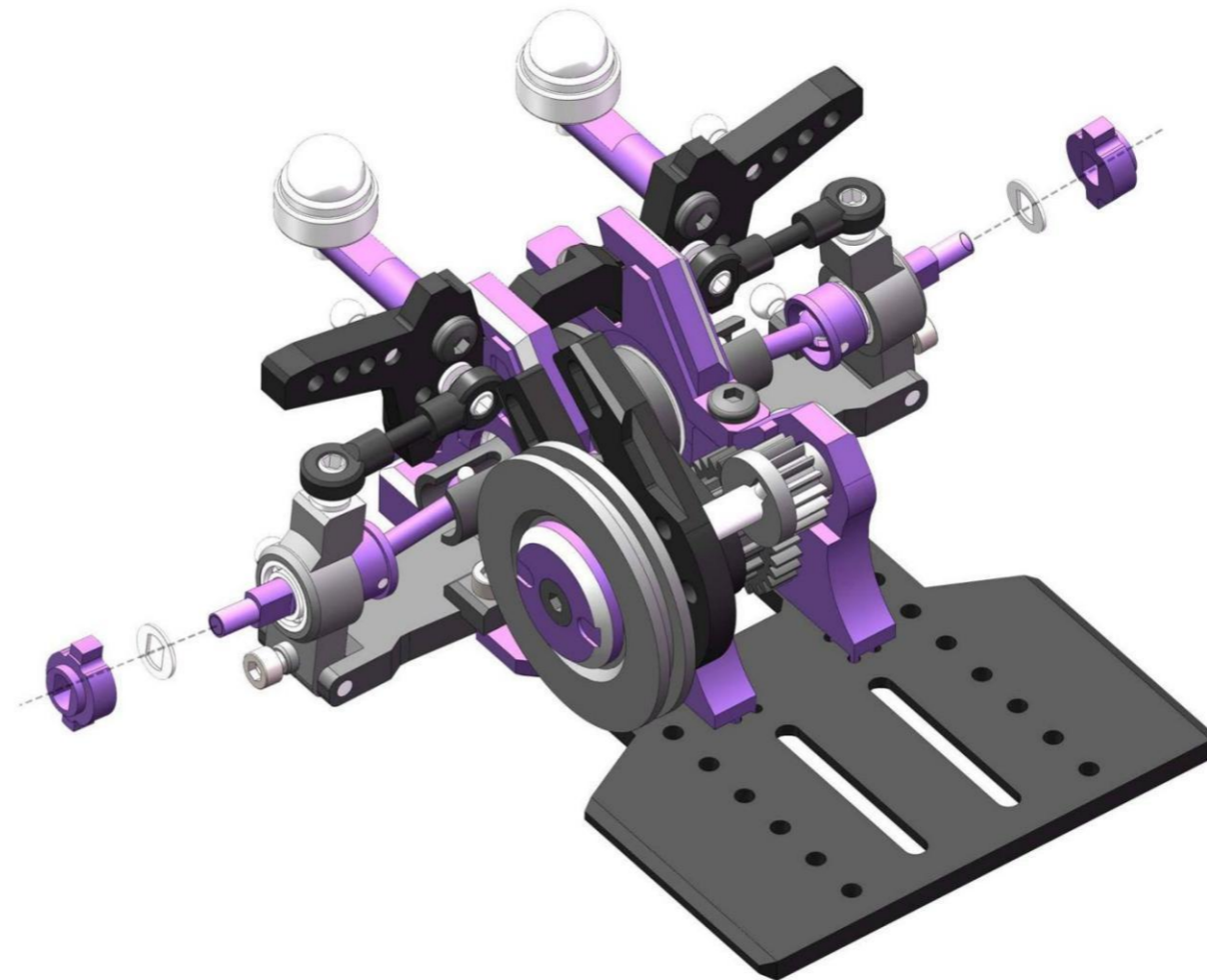

Optional Bearing fasteners

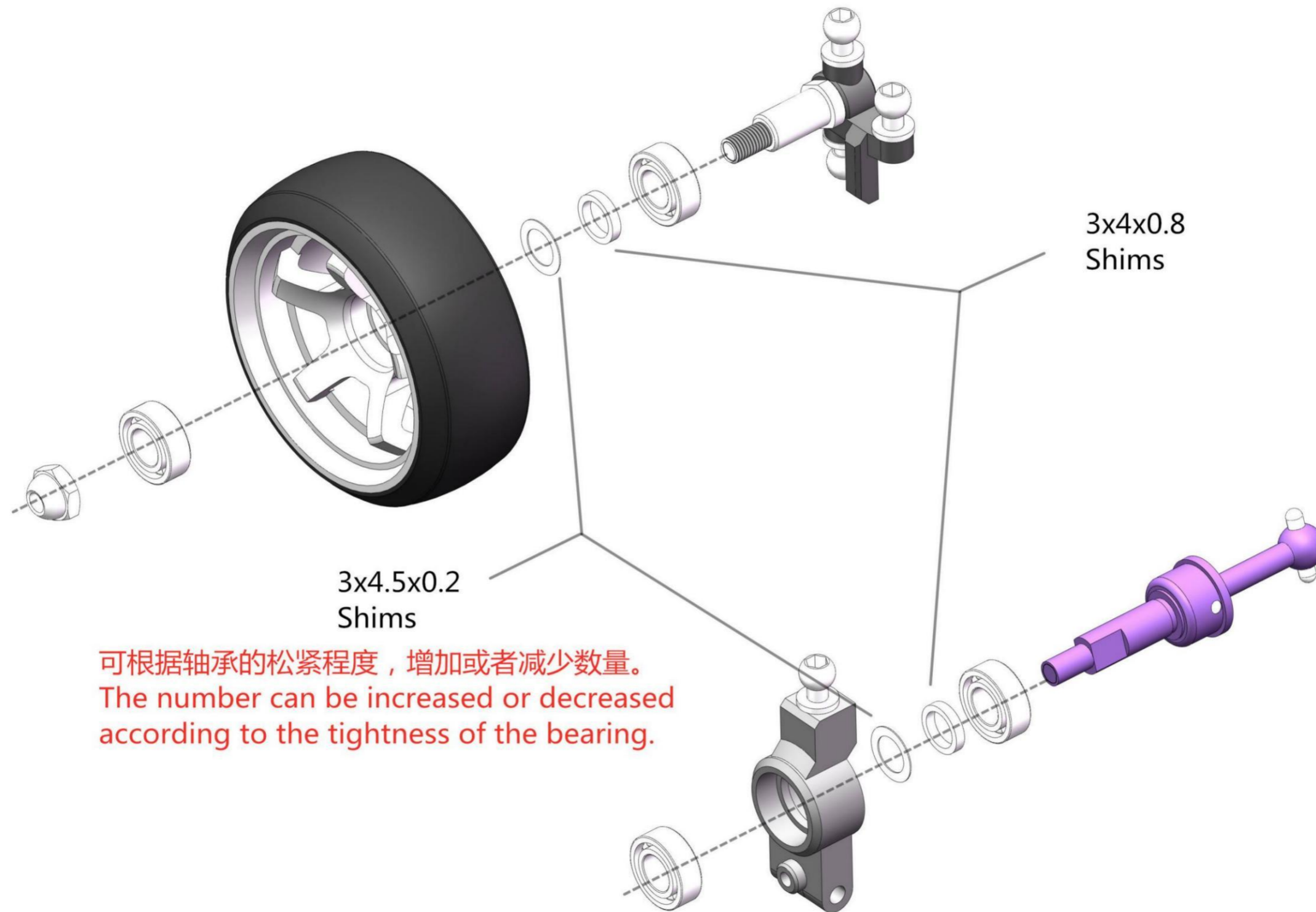

Optional spring

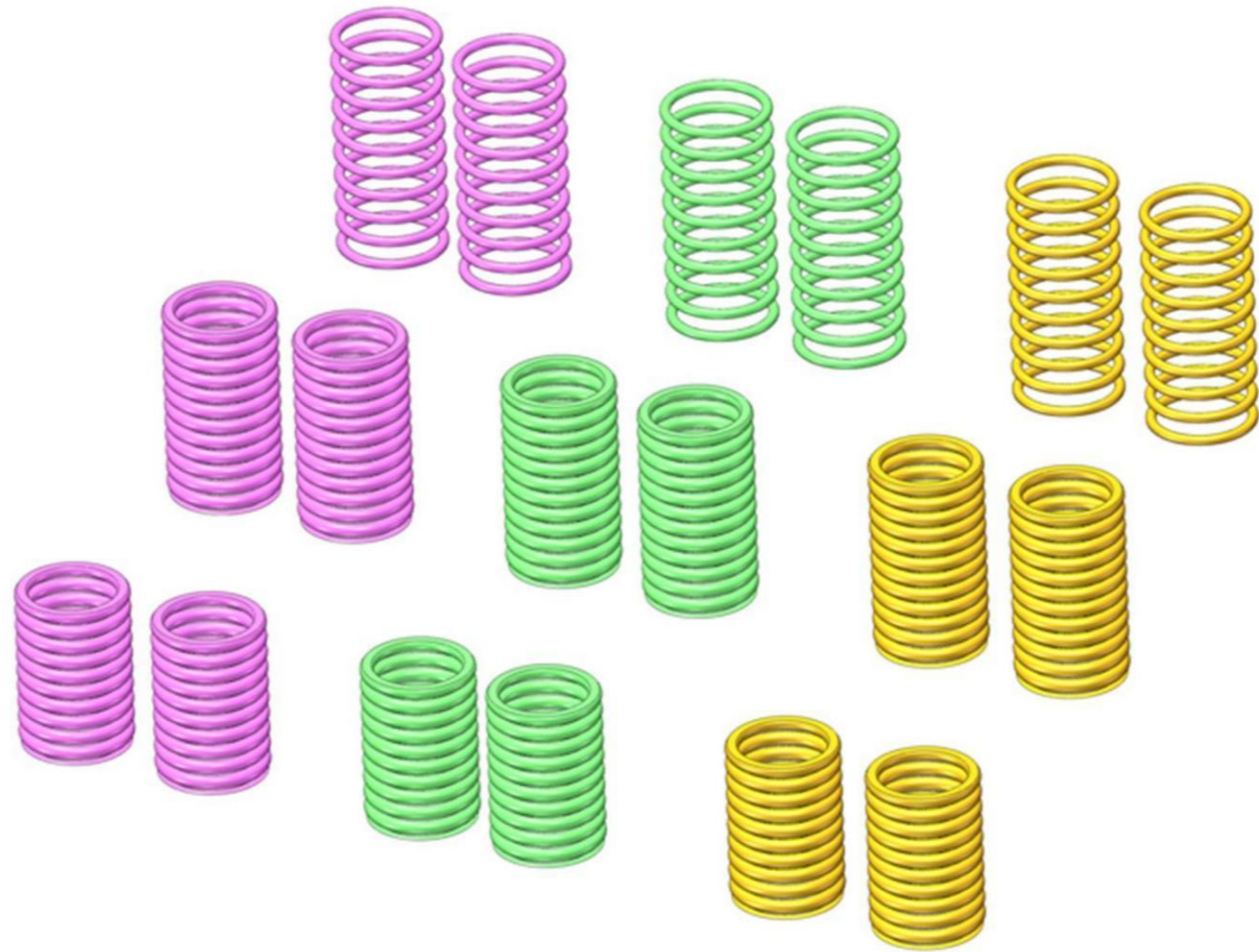

Drift tire

漂移轮胎

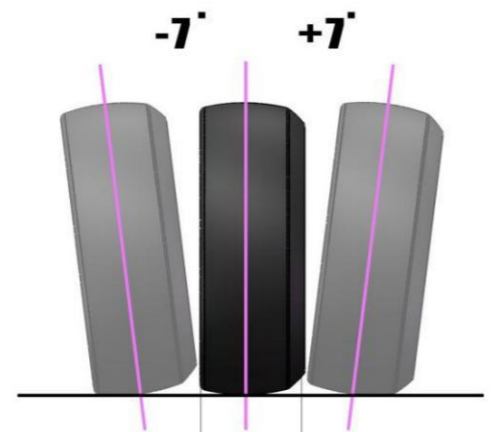

实际接触地面面积相同。
The actual contact area with the ground is the same.

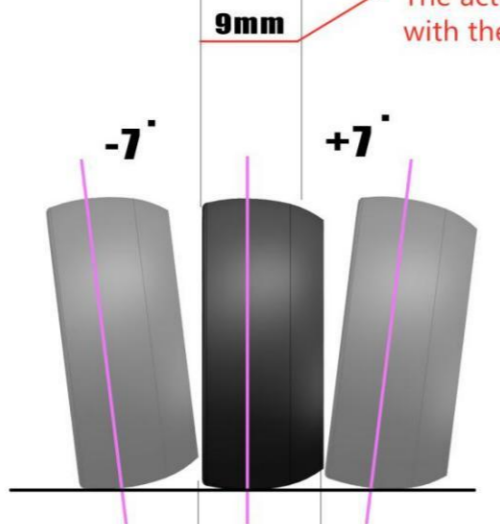

9mm

10.5mm

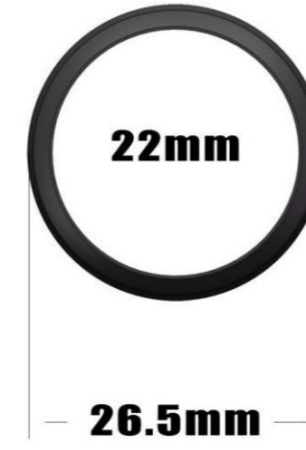

22x26.5x10.5mm



22x26.5x9mm



22x28x10.5mm



22x28x9mm

High traction differential ball

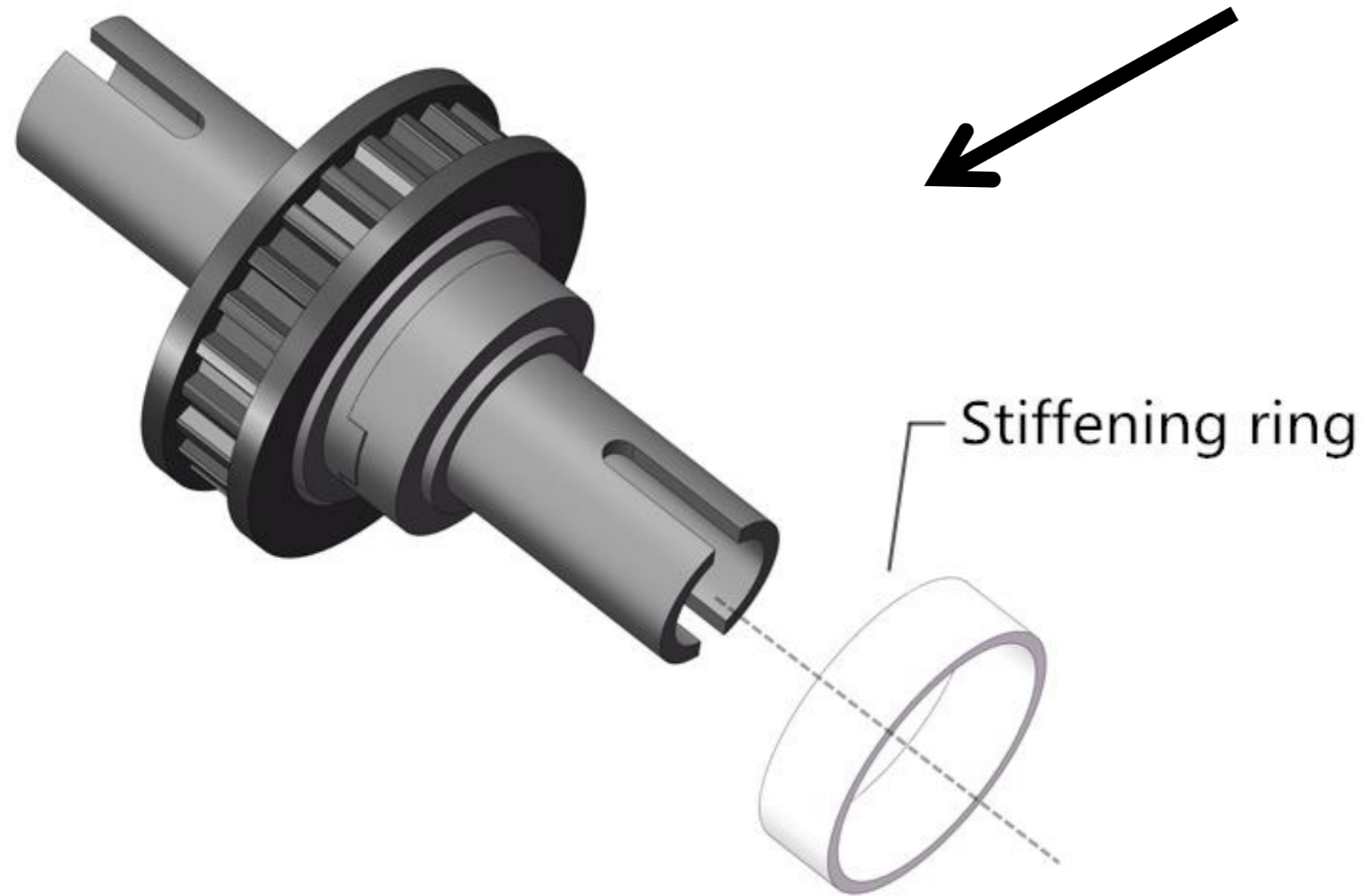

可增加顺滑度，同心度。
Smoothness and concentricity can be increased.

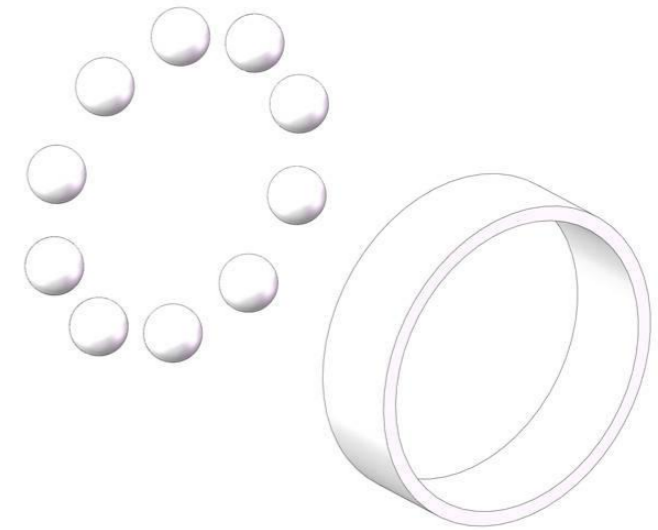

— 04

Tuning car
车架调教

Ackerman

调整转向系统



1、先把下摆臂调节成接近平行于地面

1. First adjust the lower swing arm to be nearly parallel to the ground

2、以球头作为参考物，把转向机构调到中间位置，左右对称。

2. With the ball connector as the reference object, adjust the steering mechanism to the middle position and be symmetrical left and right.

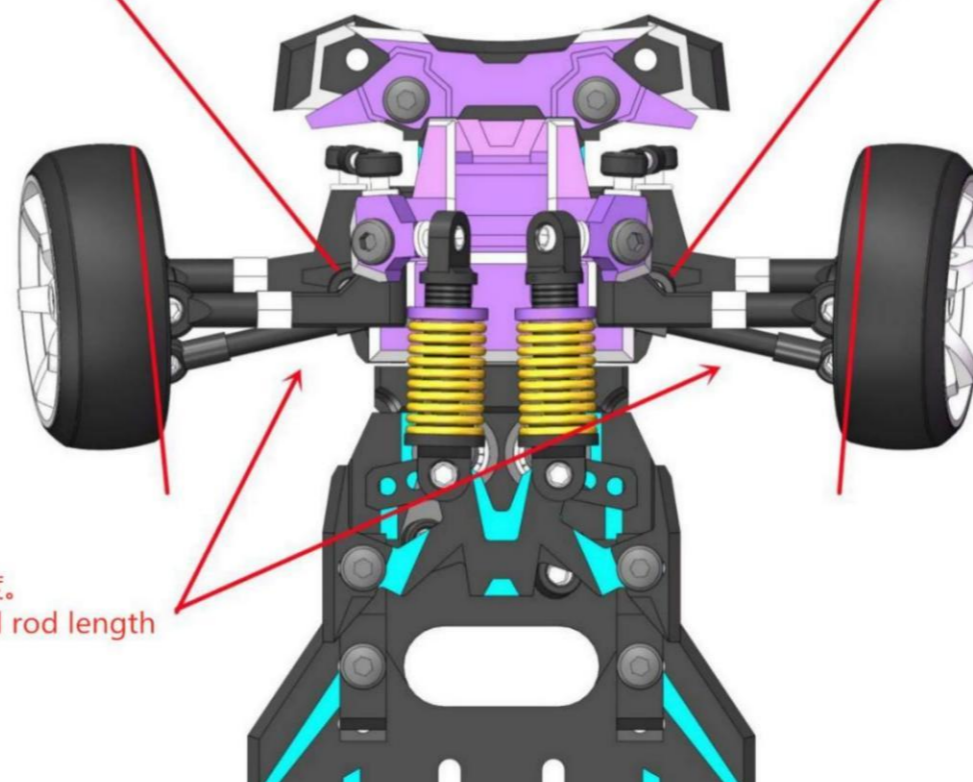

3、按照说明书的拉杆长度。

3. According to the pull rod length in the instructions.

How to observe Ackerman

如何观察阿克曼

Move the line of sight to the coincidence of the upper and lower swing arms for observation.

把视线移到上下摆臂重合进行观察。

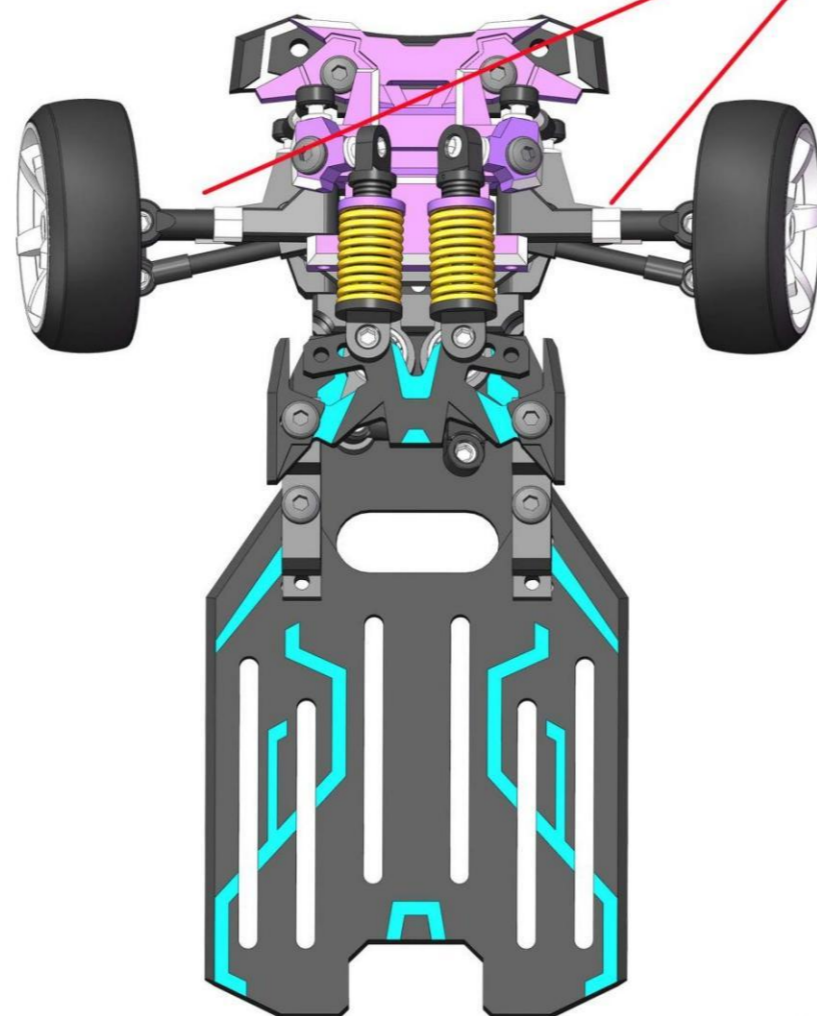

This is just above, and the upper and lower swing arms do not coincide. The observed Ackerman will be incorrect.

这是正上方，上下摆臂没有重合。观察的阿克曼将不正确。



How to adjust Ackerman

如何调节阿克曼

使用网格板作为参考

Use grid plate as reference

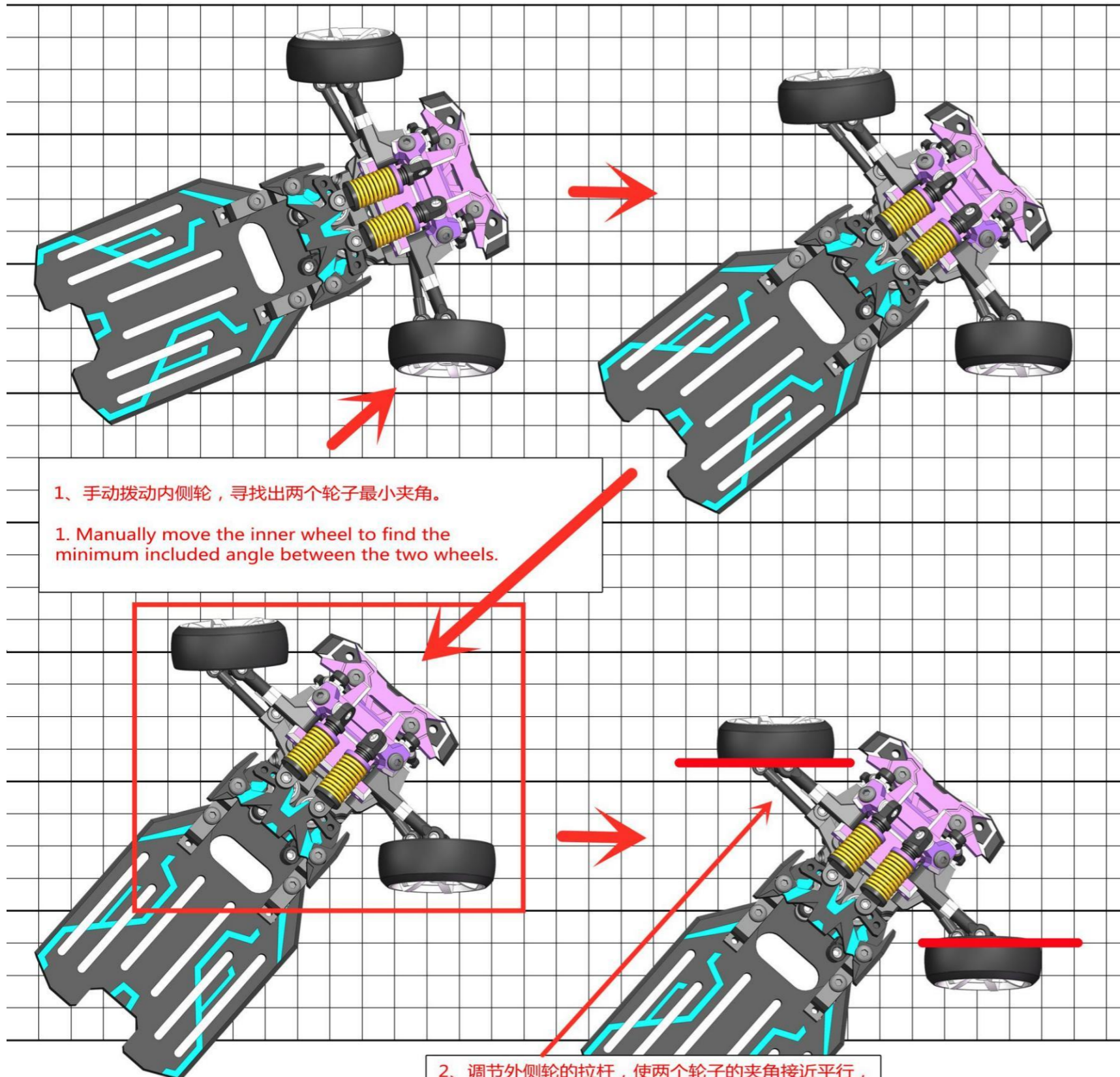

1、手动拨动内侧轮，寻找出两个轮子最小夹角。

1. Manually move the inner wheel to find the minimum included angle between the two wheels.

2、调节外侧轮的拉杆，使两个轮子的夹角接近平行，但不能出现负角度。

2. Adjust the pull rod of the outer wheel so that the included angle of the two wheels is close to parallel, but cannot appear negative angle.

注意虚线位置的上下摆臂，需要装至同一直线。如果出现偏移，请使用钳子把位置回正。
Note that the upper and lower swing arms at the dotted line need to be installed in the same straight line. If there is an offset, use pliers to correct the position.

左右使用相同方法，对称调节阿克曼。
Use the same method to adjust Ackerman symmetrically.

物理阿克曼调节完成后，然后使用遥控器把转向机构调至正中。
After the physical Ackerman adjustment is completed, then use the remote control to adjust the steering mechanism to the center.

